

PART NUMBER	REVISION	DESCRIPTION	FEED TYPE
2151234-2	G	FINE CRIMP HEIGHT ADJUST	PNEUMATIC
5-2151234-2	G	SEAL STRIPPER CRIMPER TERMINATING UNIT	PNEUMATIC
7-2151234-2	G	PNEUMATIC AND CRIMP TOOLING KIT	PNEUMATIC
7-2151234-7	A	CRIMP TOOLING KIT	-

ATLANTIC VERSION TERMINATOR INTERFACE ADAPTER

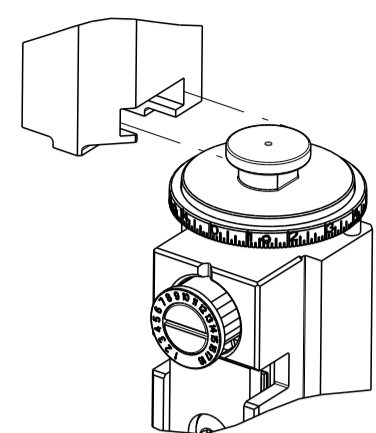

APPLICATOR DATA		
CRIMP	SIZE	TYPE
WIRE	2.03 mm [.080]	F
INSUL	6.35 mm [.250]	O

APPLICATOR INSTRUCTIONS 408-35042

TERMINAL DATA: TE TERMINAL		TE CRIMP SPECIFICATION	
TERMINAL NAME: STANDARD POWER TIMER CONTACT TYPE A			
WIRE STRIP LENGTH		TERMINAL INSULATION DIAMETER RANGE	
4.40-5.00 mm [.173-.197 IN]		∅ 1.4-2.7mm	
TERMINAL APPLICATION SPECIFICATION	114-18037	-	-
TERMINALS APPLIED			
TE TERMINAL	TE TERMINAL	TE SEAL	TE SEAL
969040-1		963243-1	∅1.4-2.1mm

TERMINAL DATA: TE TERMINAL		TE CRIMP SPECIFICATION	
TERMINAL NAME: STANDARD POWER TIMER CONTACT TYPE A			
WIRE STRIP LENGTH		TERMINAL INSULATION DIAMETER RANGE	
3.90-4.50 mm [.153-.177 IN]		∅ 1.4-2.7mm	
TERMINAL APPLICATION SPECIFICATION	114-18388	-	-
TERMINALS APPLIED			
TE TERMINAL	TE TERMINAL	TE SEAL	TE SEAL
1241412-1	1241412-3		963243-1

WIRE SIZE	CRIMP HEIGHT mm [INCH]	CRIMP HEIGHT REFERENCE SETTING
1.00mm2	1.52+/-0.05 [1.060+/- .002]	7.6
0.75mm2	1.43+/-0.05 [1.056+/- .002]	8.5
0.50mm2	1.34+/-0.05 [1.053+/- .002]	9.6

WIRE SIZE	CRIMP HEIGHT mm [INCH]	CRIMP HEIGHT REFERENCE SETTING
1.00mm2	1.54+/-0.05 [1.061+/- .002]	7.6
0.75mm2	1.47+/-0.05 [1.058+/- .002]	8.5
0.50mm2	1.43+/-0.05 [1.056+/- .002]	9.6

- RECOMMENDED SPARE PARTS
 - REFER TO SUPPLIED INSTRUCTION SHEET FOR CLEANING, LUBRICATION & STORAGE OF APPLICATOR.
 - APPLY PART NUMBER 1-23419-5 LOCTITE TO THREADS OF ITEM 180. APPLY PART NUMBER 2-23419-6 LOCTITE TO THREADS OF ITEM 242.
 - CRIMP HEIGHT REFERENCE SETTING WAS THE SETTING USED WHEN THE APPLICATOR WAS QUALIFIED AT THE FACTORY. ADJUSTMENT MAY BE NECESSARY WHEN RUNNING APPLICATOR IN THE FIELD.
 - TERMINAL PITCH NOT COMPATIBLE WITH MECHANICAL FEED.
 - APPLY TORQ-SEAL IN ALLEN SOCKET TO FILL HOLE AFTER FLAT HD HAS BEEN ADJUSTED TO CORRECT HEIGHT AT QUALIFICATION. APPLY #1-23419-5 LOC-TITE TO THREADS.
 - TERMINAL LUBRICANT IS RECOMMENDED.
8. UNLESS SPECIFIED OTHERWISE TORQUE VALUES SHALL BE USED PER DOCUMENT, 101-35000.

***WARNING**
ON INSTALLATION, SET WIRE DISC TO CRIMP HEIGHT REFERENCE SETTING FOR LARGEST WIRE SIZE. CRIMP HEIGHT REFERENCE SETTINGS GREATER THAN THE VALUE SHOWN MAY CAUSE DAMAGE TO THE CRIMP TOOLING, REFER TO THE INSTRUCTION SHEET FOR PROPER SETUP AND ADJUSTMENTS.

ATLANTIC VERSION
Shown on sheets 1 of 4 & 2 of 4
(Pacific version shown on sheets 3 of 4 & 4 of 4)

LOC	DIST	REVISIONS					
A	66	P	LTN	DESCRIPTION	DATE	DWN	APVD
		E		ECR-18-018975	04DEC2018	FJ	KZ
		F		ECR-19-005517	05APR2019	LG	TE
		F1		ECR-20-014998	21OCT2020	JWC	GB
		G		ECR-22-145388	07JUL2022	TB	JH

-	-	1	-	1803515-3	RAM ASSEMBLY, SF ATLANTIC	293	
-	-	1	-	2-1803583-1	APPLICATOR BASIC ASSEMBLY, SF	292	
-	1	1	1	2119641-1	FEED CAM, AIR FEED	248	
-	1	1	1	2119082-8	CAM, SNAIL, INSULATION ADJUSTMENT	244	
-	1	1	1	2079764-1	WASHER, WAVE SPRING, CREST-TO-CREST	243	
-	1	1	1	2119083-1	RETAINER, INSULATION DIAL	242	
-	1	1	1	7-18023-7	SCR, SKT HD CAP M3 X 4.0	241	
-	1	1	1	2844940-1	AIR FEED MODULE	238	
-	-	1	-	4-1722335-3	STRIPPER, SIDE FEED	182	
-	-	1	-	1-5018030-0	NUT, HEX, REG, RoHS, M3.5	181	
-	-	1	-	2-1752354-2	STANDOFF, HOLD-DOWN	180	
-	-	1	-	993111-1	PIN, SLOTTED SPRING 3.0 X 20.0	177	
-	-	1	-	5-22280-0	SPRING, COMPRESSION	176	
-	-	1	-	1752353-3	GUIDE PIN, HOLDDOWN	175	
-	-	1	-	1901680-2	GUIDE PIN, HOLDDOWN	174	
-	REF	REF	REF	994970-2	COUNTER, MAGNETIC	164	
-	1	1	1	2119955-1	ASSY, LUBRICATOR, SIDE FEED	113	
-	1	1	1	2844908-1	SCREW, LOCKING	99	
-	1	1	1	2844907-1	POST, LOCKING	98	
-	1	1	1	455888-5	SPACER, CRIMPER	82	
-	1	1	1	1803607-3	DOCUMENTATION PACKAGE	71	
-	1	1	1	2119740-1	TAG, IDENTIFICATION	67	
-	2	2	2	2168078-1	SCREW, DRIVE, RH, RoHS, 2 x .188	66	
-	1	1	1	2168083-2	SCR, SKT HD CAP, RoHS, M4 X 8.0	60	
-	1	1	1	5-18022-5	SCR, HEX HD CAP, M4 X 6.0	59	
-	1	1	1	985575-3	SCR, FLT SKT HD CAP M3 X 10.0	57	
-	1	1	1	1338685-1	PAWL, FEED	56	
-	4	4	4	2168083-3	SCR, SKT HD CAP, RoHS, M4 X 12.0	54	
-	2	2	2	2168083-3	SCR, SKT HD CAP, RoHS, M4 X 12.0	53	
-	1	1	1	1803382-2	HOLD DOWN, SPRING LOADED	50	
-	1	1	1	18023-9	SCR, SKT HD CAP M4 X 6.0	49	
-	1	-	1	1803583-9	APPLICATOR BASIC ASSEMBLY, SF	46	
-	1	-	1	1803515-1	RAM ASSEMBLY, SF ATLANTIC	44	
-	1	1	1	1803602-1	SCR, BHSC, RoHS (M8 X 25)	41	
-	1	1	1	1-1752356-1	SUPPORT, TERMINAL	34	
-	2	2	2	2079383-5	SCR, BHSC, RoHS (M4 X 20)	33	
-	2	2	2	3-2844962-2	SPACER, CYLINDRICAL, STRIP GUIDE	30	
-	1	1	1	2844992-2	ASSEMBLY, STRIP GUIDE	29	
-	1	1	1	455888-3	SPACER, CRIMPER	28	
-	1	1	1	1320928-6	STRIP GUIDE	24	
-	1	-	1	2168083-2	SCR, SKT HD CAP, RoHS, M4 X 8.0	21	
-	2	1	2	1-18028-2	WASHER, FLAT, REG M4	20	
-	1	-	1	2119533-1	STRIPPER, SIDE FEED	19	
-	1	1	1	2119806-1	INSERT, SHEAR	13	
-	1	1	1	3-22280-3	SPRING, COMPRESSION	12	
-	1	1	1	1-356885-4	STOP, SHEAR	11	
-	1	1	1	2119805-1	SHEAR HOLDER, FRONT	10	
-	1	1	1	318707-1	FLOATING SHEAR, FRONT	9	
-	1	2	1	1	4-1333204-2	ANVIL, COMBINATION	8
-	1	1	1	1	8-240641-6	SPACER	7
-	1	1	1	1	2119781-1	DEPRESSOR, SHEAR	5
-	1	1	1	1	238011-2	BLOCK, CRIMPER SPACER	4
-	1	2	1	1	1633996-6	CRIMPER, INSULATION SPECIAL	3
-	1	1	1	1	455888-9	SPACER, CRIMPER	2
-	1	2	1	1	1-456405-6	CRIMPER, WIRE PREMIUM	1
-	77	-72	-52	-2	PART NO	DESCRIPTION	ITEM NO

DIMENSIONS:		TOLERANCES UNLESS OTHERWISE SPECIFIED:		DRAWING NO		RESTRICTED TO	
mm	0 PLC ±	1 PLC ±	2 PLC ±	3 PLC ±	4 PLC ±	ANGLES ±	FINISH
MATERIAL				WEIGHT	SCALE	SHEET	REV
Customer Accessible Production Drawing				SCALE	1:2	SHEET 1 of 4	REV G

LOC	DIST	REVISIONS					
A	66	P	LTN	DESCRIPTION	DATE	OWN	APVD
		-		SEE SHEET 1			

FEED TYPE

PNEUMATIC

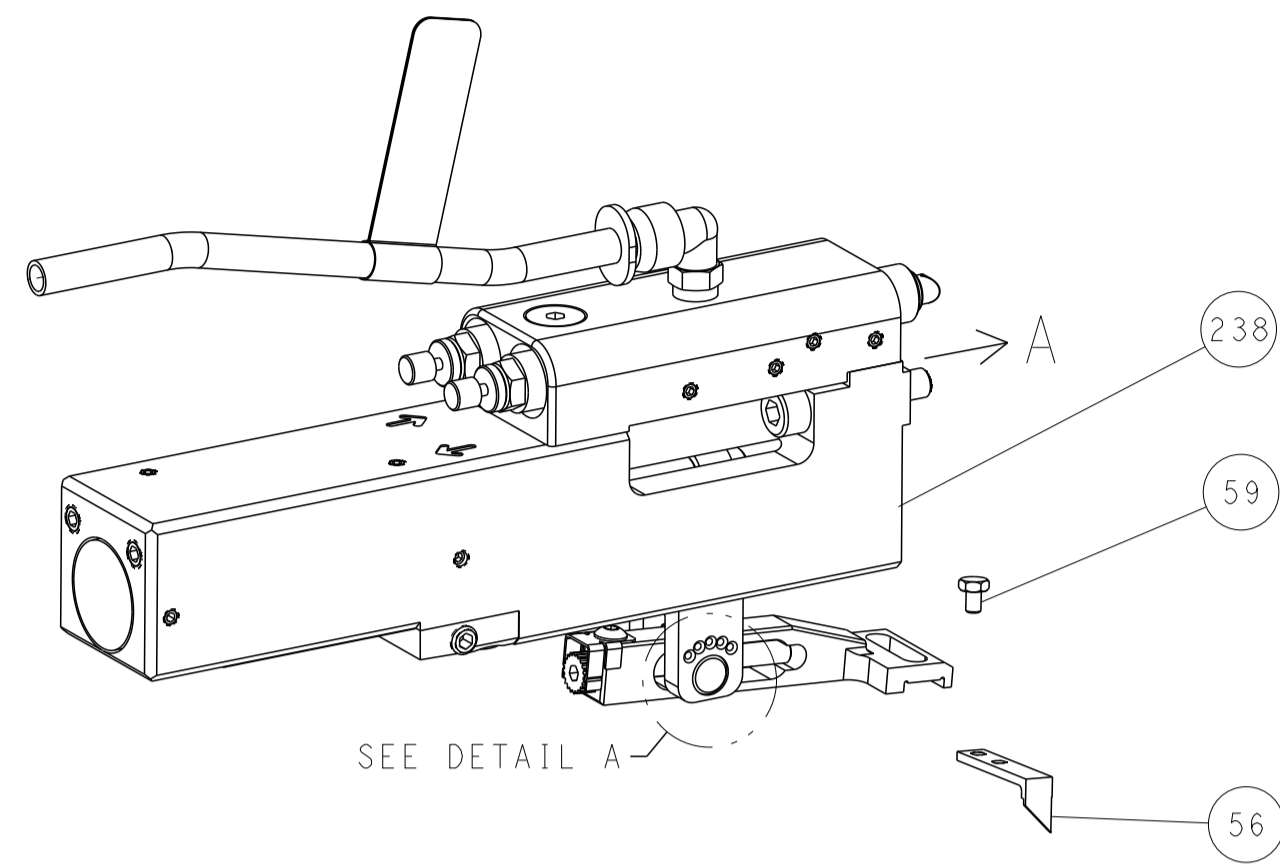

FEED SPRING SETTING POSITION
(SHOWN FROM REAR SIDE)

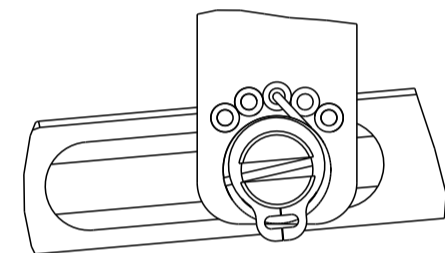

DETAIL A

CAM POSITION

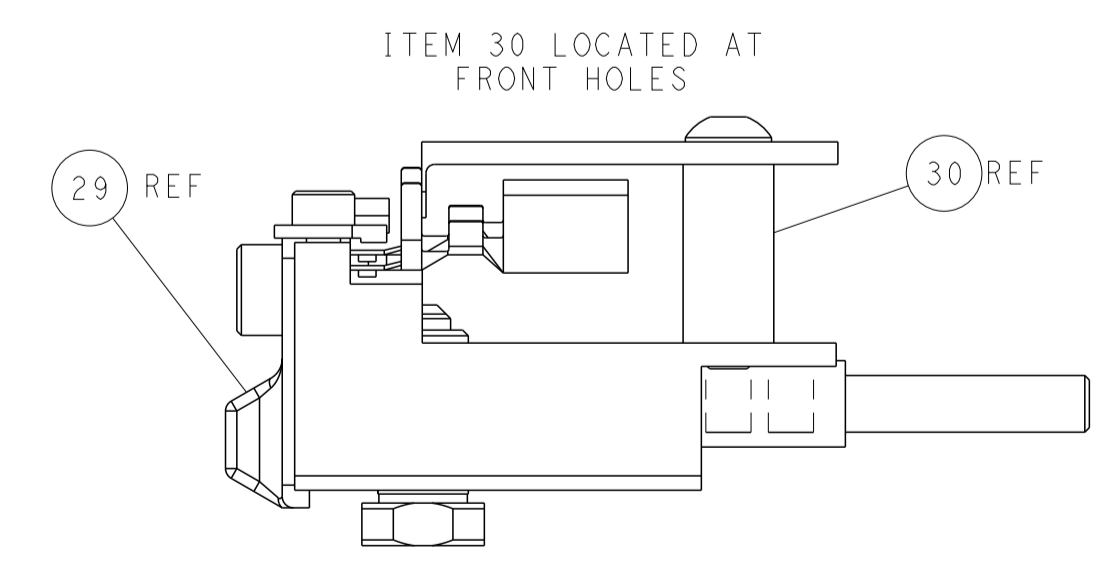
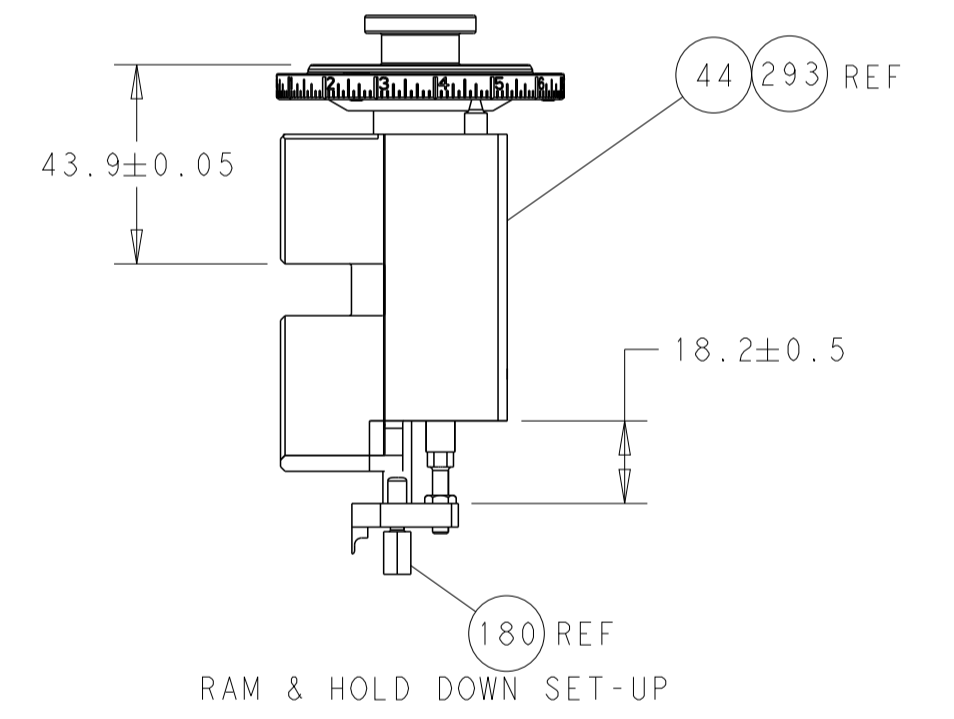
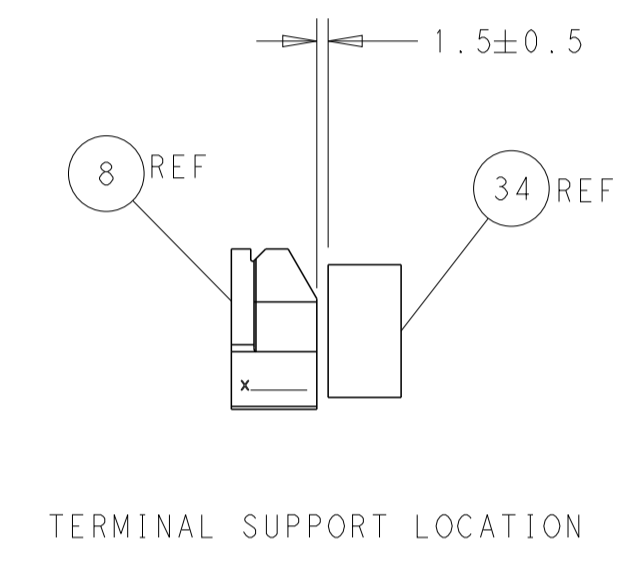
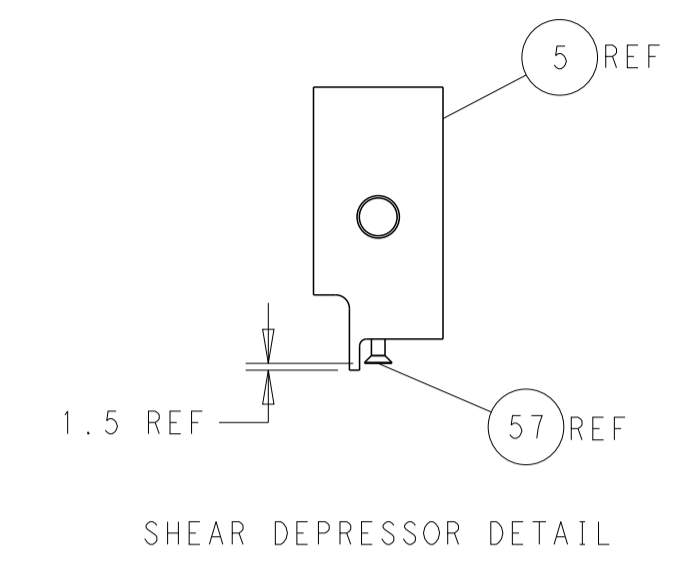
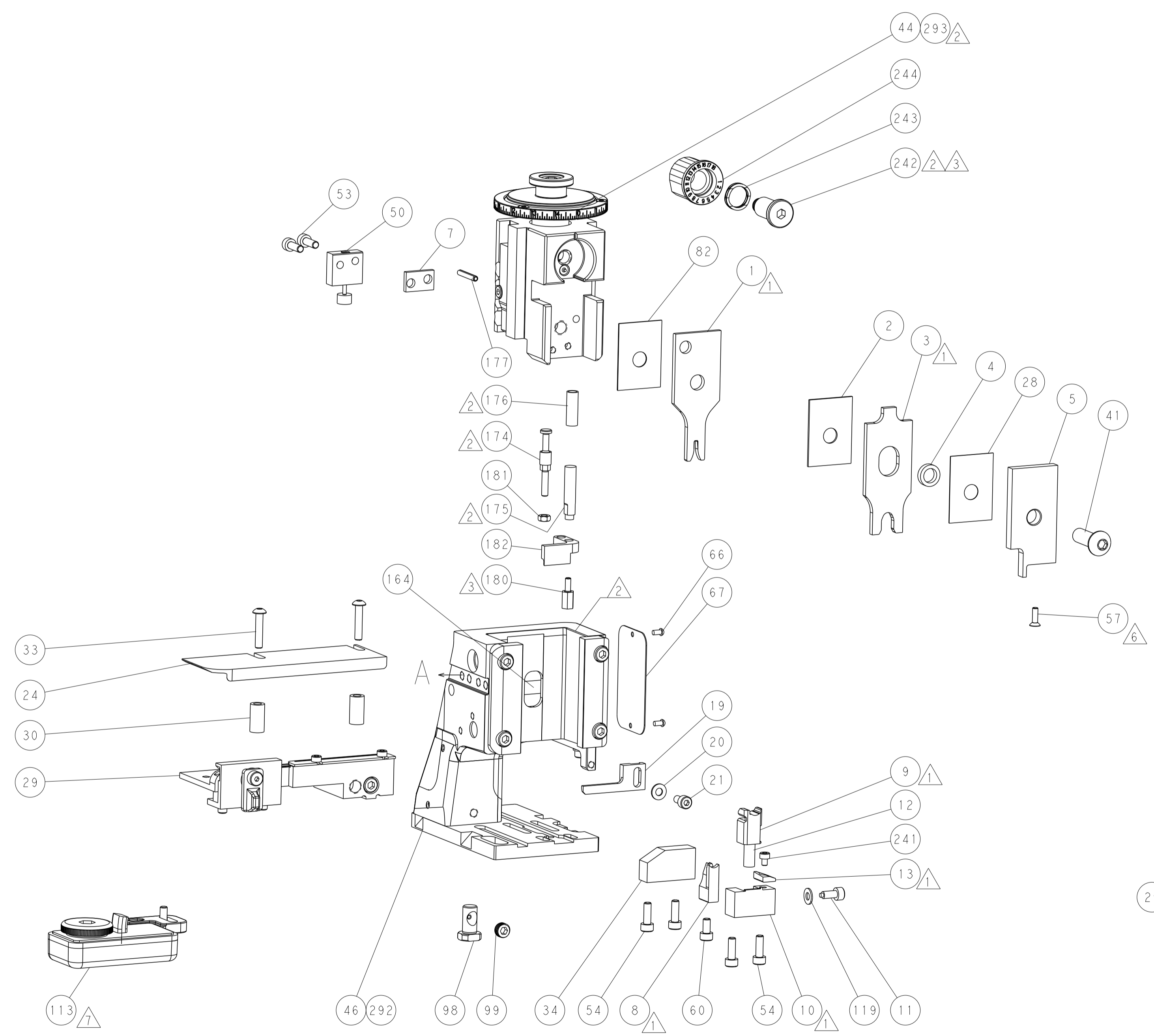
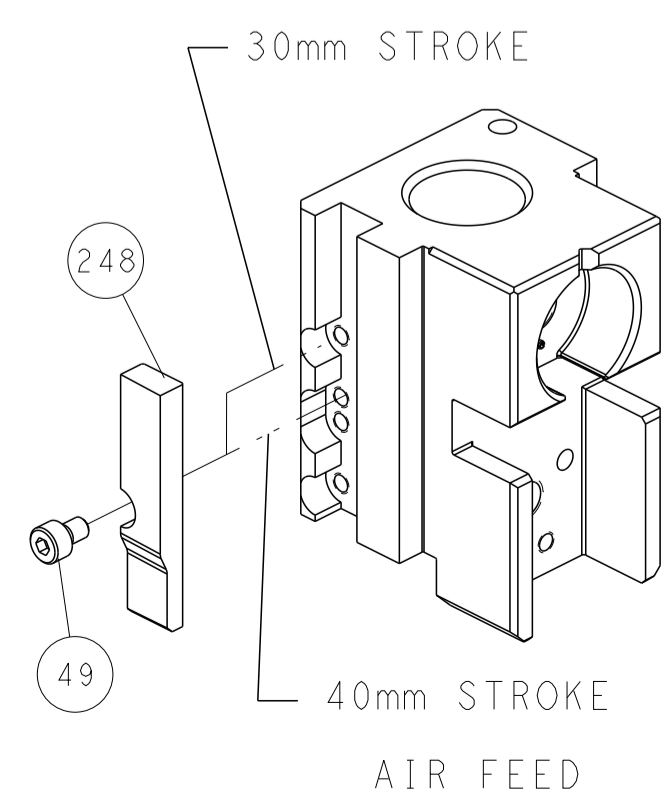

ATLANTIC VERSION
 Shown on sheets 1 of 4 & 2 of 4
 (Pacific version shown on sheets 3 of 4 & 4 of 4)

DIMENSIONS:		TOLERANCES UNLESS OTHERWISE SPECIFIED:		DWG L. ZHANG 22SEP2011		TE Connectivity	
mm	0 PLC ±	1 PLC ±	2 PLC ±	3 PLC ±	4 PLC ±	5 PLC ±	Harrisburg, PA 17105-3608
	ANGLES	FINISH		APVD S. XI 22SEP2011	NAME	Ocean Side Feed Applicator	
MATERIAL				PRODUCT SPEC	SIZE	CAGE CODE	DRAWING NO
				APPLICATION SPEC	A1	00779	2151234
				RESTRICTED TO	WEIGHT	SCALE	1:2
				Customer Accessible Production Drawing	SHEET	2	OF 4
					REV	G	

THIS DRAWING IS UNPUBLISHED.	RELEASED FOR PUBLICATION		
COPYRIGHT 20 BY TYCO ELECTRONICS CORPORATION. ALL RIGHTS RESERVED.			
PART NUMBER	REVISION	DESCRIPTION	FEED TYPE
2-2151234-2	G	FINE CRIMP HEIGHT ADJUST	PNEUMATIC
7-2151234-7	A	CRIMP TOOLING KIT	-

PACIFIC VERSION TERMINATOR
INTERFACE ADAPTER

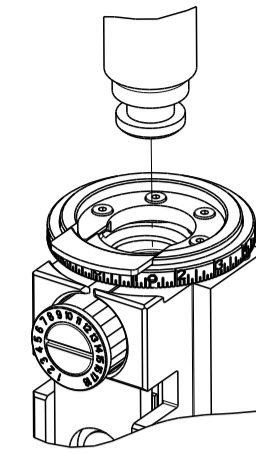

APPLICATOR DATA		
CRIMP	SIZE	TYPE
WIRE	2.03 mm [.080]	F
INSUL	6.35 mm [.250]	O
APPLICATOR INSTRUCTIONS 408-35042		

TERMINAL DATA: TE TERMINAL		TE CRIMP SPECIFICATION	
TERMINAL NAME: STANDARD POWER TIMER CONTACT TYPE A			
WIRE STRIP LENGTH		TERMINAL INSULATION DIAMETER RANGE	
4.40-5.00 mm [.173-.197 IN]		∅ 1.4-2.7mm	
TERMINAL APPLICATION SPECIFICATION	114-18037	-	-

TERMINALS APPLIED			
TE TERMINAL	TE TERMINAL	TE SEAL	TE SEAL
969040-1			963243-1

SEAL INSULATION DIAMETER RANGE	∅1.4-2.1mm
--------------------------------	------------

TERMINAL DATA: TE TERMINAL		TE CRIMP SPECIFICATION	
TERMINAL NAME: STANDARD POWER TIMER CONTACT TYPE A			
WIRE STRIP LENGTH		TERMINAL INSULATION DIAMETER RANGE	
3.90-4.50 mm [.153-.177 IN]		∅ 1.4-2.7mm	
TERMINAL APPLICATION SPECIFICATION	114-18388	-	-

TERMINALS APPLIED			
TE TERMINAL	TE TERMINAL	TE SEAL	TE SEAL
1241412-1	1241412-3		963243-1

SEAL INSULATION DIAMETER RANGE	∅1.4-2.1mm
--------------------------------	------------

WIRE SIZE	CRIMP HEIGHT mm [INCH]	CRIMP HEIGHT REFERENCE SETTING
1.00mm2	1.52+/-0.05 [.060+/- .002]	7.6
0.75mm2	1.43+/-0.05 [.056+/- .002]	8.5
0.50mm2	1.34+/-0.05 [.053+/- .002]	9.6

WIRE SIZE	CRIMP HEIGHT mm [INCH]	CRIMP HEIGHT REFERENCE SETTING
1.00mm2	1.54+/-0.05 [.061+/- .002]	7.6
0.75mm2	1.47+/-0.05 [.058+/- .002]	8.5
0.50mm2	1.43+/-0.05 [.056+/- .002]	9.6

- RECOMMENDED SPARE PARTS
 - REFER TO SUPPLIED INSTRUCTION SHEET FOR CLEANING, LUBRICATION & STORAGE OF APPLICATOR.
 - APPLY PART NUMBER 2-23419-6 LOCTITE TO THREADS OF ITEM 242.
 - CRIMP HEIGHT REFERENCE SETTING WAS THE SETTING USED WHEN THE APPLICATOR WAS QUALIFIED AT THE FACTORY. ADJUSTMENT MAY BE NECESSARY WHEN RUNNING APPLICATOR IN THE FIELD.
 - TERMINAL PITCH NOT COMPATIBLE WITH MECHANICAL FEED.
 - APPLY TORQ-SEAL IN ALLEN SOCKET TO FILL HOLE AFTER FLAT HD HAS BEEN ADJUSTED TO CORRECT HEIGHT AT QUALIFICATION. APPLY #1-23419-5 LOC-TITE TO THREADS.
 - TERMINAL LUBRICANT IS RECOMMENDED.
8. UNLESS SPECIFIED OTHERWISE TORQUE VALUES SHALL BE USED PER DOCUMENT, 101-35000.

***WARNING**
ON INSTALLATION, SET WIRE DISC TO CRIMP HEIGHT REFERENCE SETTING FOR LARGEST WIRE SIZE. CRIMP HEIGHT REFERENCE SETTINGS GREATER THAN THE VALUE SHOWN MAY CAUSE DAMAGE TO THE CRIMP TOOLING, REFER TO THE INSTRUCTION SHEET FOR PROPER SETUP AND ADJUSTMENTS.

PACIFIC VERSION
Shown on sheets 3 of 4 & 4 of 4
(Atlantic version shown on sheets 1 of 4 & 2 of 4)

LOC	DIST	REV	DATE	BY	APPV
A	66	-	-	-	-

REV	DATE	BY	APPV	DESCRIPTION	ITEM NO
-	1			2119082-8 CAM, SNAIL, INSULATION ADJUSTMENT	244
-	1			2079764-1 WASHER, WAVE SPRING, CREST-TO-CREST	243
-	1			2119083-1 RETAINER, INSULATION DIAL	242
-	1			7-18023-7 SCR, SKT HD CAP M3 X 4.0	241
-	1			2844940-1 AIR FEED MODULE	238
-	REF			994970-2 COUNTER, MAGNETIC	164
-	1			2119641-2 FEED CAM, AIR FEED	151
-	1			2168083-8 SCR, SKT HD CAP, RoHS, M4 X 16	144
-	4			2168083-9 SCR, SKT HD CAP, RoHS, M4 X 20	143
-	1			1-1803583-0 APPLICATOR BASIC ASSEMBLY, SF	141
-	1			1803516-1 RAM ASSEMBLY, SF PACIFIC	140
-	1			2119955-1 ASSY, LUBRICATOR, SIDE FEED	113
-	1			2844908-1 SCREW, LOCKING	99
-	1			2844907-1 POST, LOCKING	98
-	1			455888-5 SPACER, CRIMPER	82
-	1			1803607-3 DOCUMENTATION PACKAGE	71
-	1			2119740-1 TAG, IDENTIFICATION	67
-	2			2168078-1 SCREW, DRIVE, RH, RoHS, 2 x .188	66
-	1			5-18022-5 SCR, HEX HD CAP, M4 X 6.0	59
-	1			985575-3 SCR, FLT SKT HD CAP M3 X 10.0	57
-	1			1338685-1 PAWL, FEED	56
-	2			2168083-3 SCR, SKT HD CAP, RoHS, M4 X 12.0	53
-	1			1803382-2 HOLD DOWN, SPRING LOADED	50
-	1			18023-9 SCR, SKT HD CAP M4 X 6.0	49
-	1			1803602-1 SCR, BHSC, RoHS (M8 X 25)	41
-	1			1-1752356-1 SUPPORT, TERMINAL	34
-	2			2079383-5 SCR, BHSC, RoHS (M4 X 20)	33
-	2			3-2844962-2 SPACER, CYLINDRICAL, STRIP GUIDE	30
-	1			2844992-2 ASSEMBLY, STRIP GUIDE	29
-	1			455888-3 SPACER, CRIMPER	28
-	1			1320928-6 STRIP GUIDE	24
-	1			2168083-2 SCR, SKT HD CAP, RoHS, M4 X 8.0	21
-	2			1-18028-2 WASHER, FLAT, REG M4	20
-	1			2119533-1 STRIPPER, SIDE FEED	19
-	1			2119806-1 INSERT, SHEAR	13
-	1			3-22280-3 SPRING, COMPRESSION	12
-	1			1-356885-4 STOP, SHEAR	11
-	1			2119805-1 SHEAR HOLDER, FRONT	10
-	1			318707-1 FLOATING SHEAR, FRONT	9
-	1			4-1333204-2 ANVIL, COMBINATION	8
-	1			8-240641-6 SPACER	7
-	1			2119781-1 DEPRESSOR, SHEAR	5
-	1			238011-2 BLOCK, CRIMPER SPACER	4
-	1			1633996-6 CRIMPER, INSULATION SPECIAL	3
-	1			455888-9 SPACER, CRIMPER	2
-	1			1-456405-6 CRIMPER, WIRE PREMIUM	1

DIMENSIONS: mm		TOLERANCES UNLESS OTHERWISE SPECIFIED:		DWN L. ZHANG 22SEP2011		CHK L. ZHANG 22SEP2011		APVD S. XI 22SEP2011		NAME Ocean Side Feed Applicator	
0 PLC ±		1 PLC ±		2 PLC ±		3 PLC ±		4 PLC ±		RESTRICTED TO	
ANGLES FINISH		MATERIAL		WEIGHT		SCALE		SHEET		REV	
						A1 00779 ©=2151234		3 OF 4		G	

LOC	DIST	REVISIONS					
A	66	P	LYN	DESCRIPTION	DATE	OWN	APVD
		-		SEE SHEET 1			

FEED TYPE PNEUMATIC

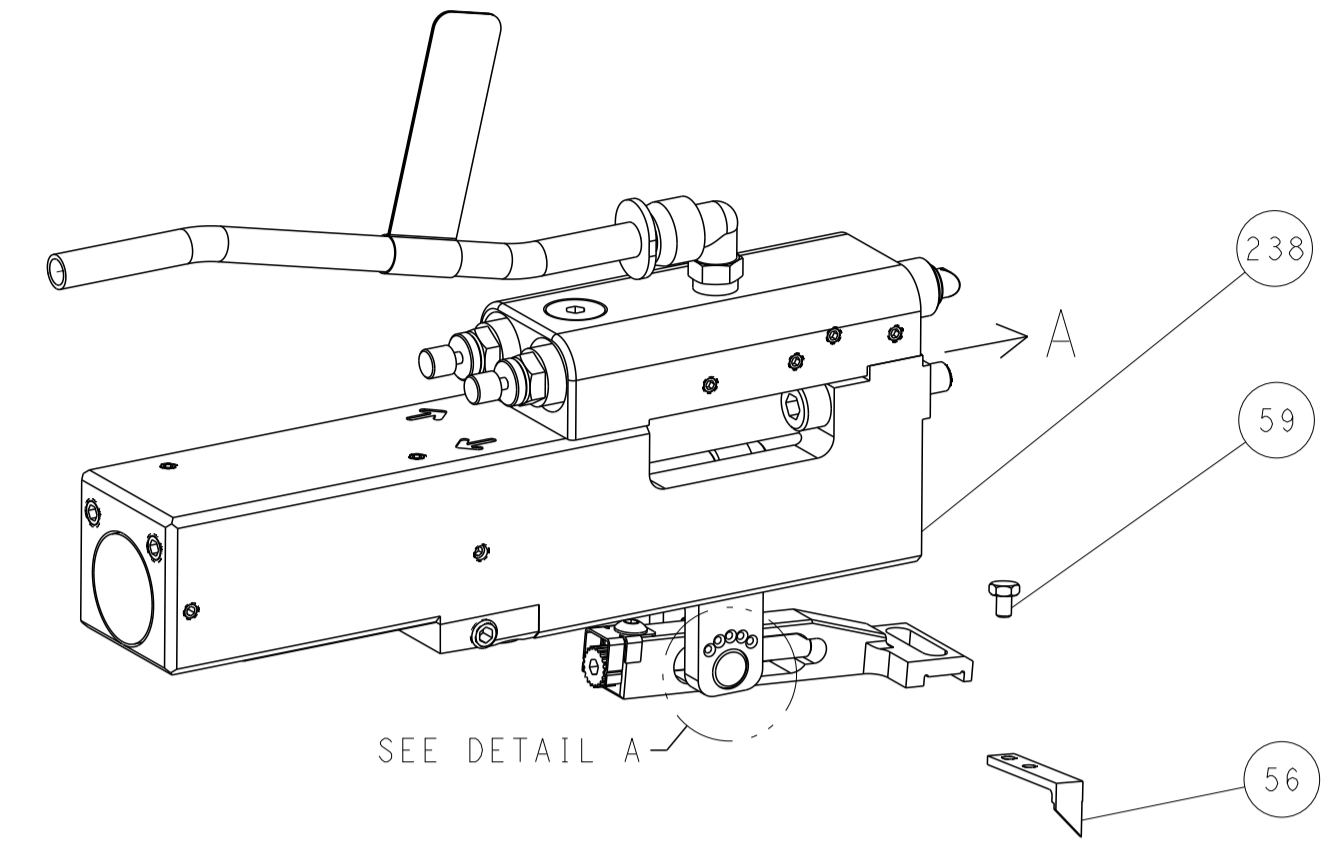

SEE DETAIL A

FEED SPRING SETTING POSITION (SHOWN FROM REAR SIDE)

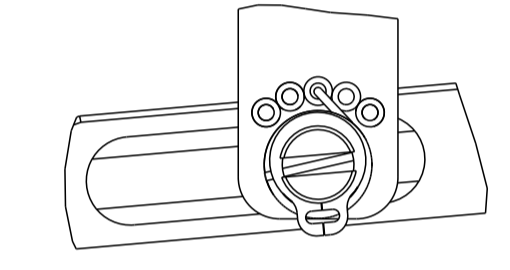

DETAIL A

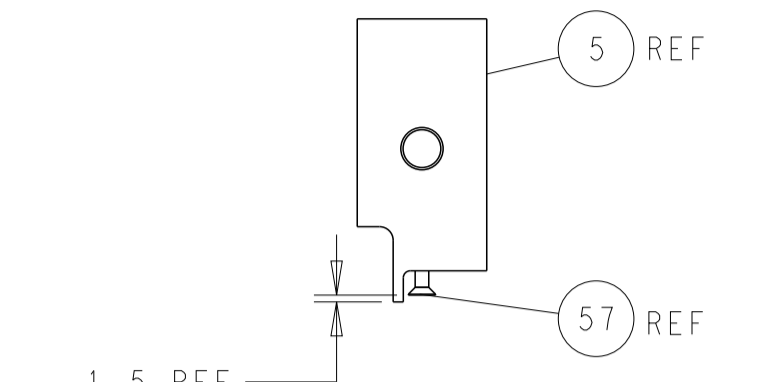

SHEAR DEPRESSOR DETAIL

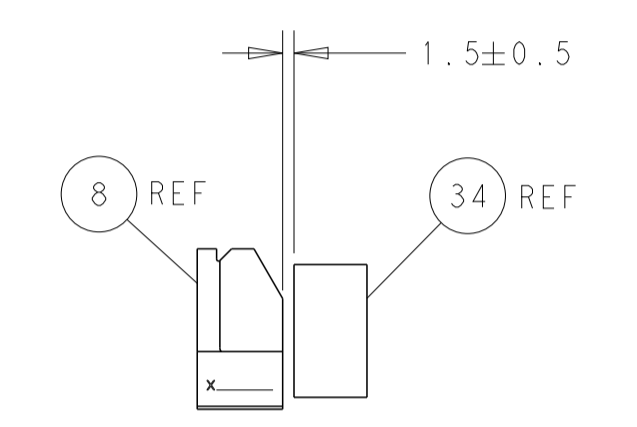

TERMINAL SUPPORT LOCATION

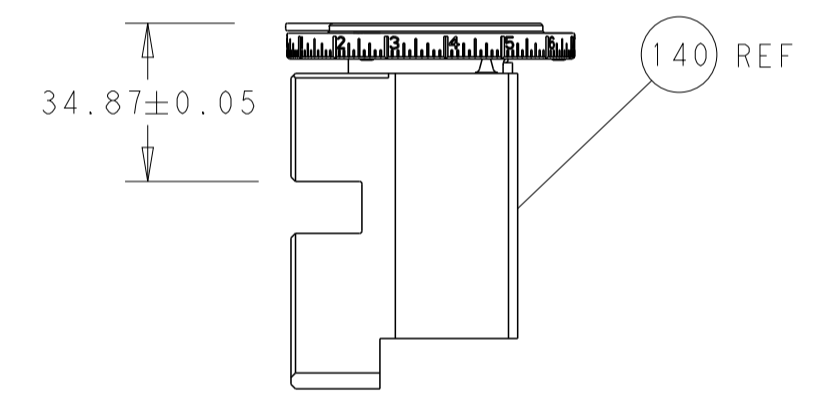

RAM SET-UP

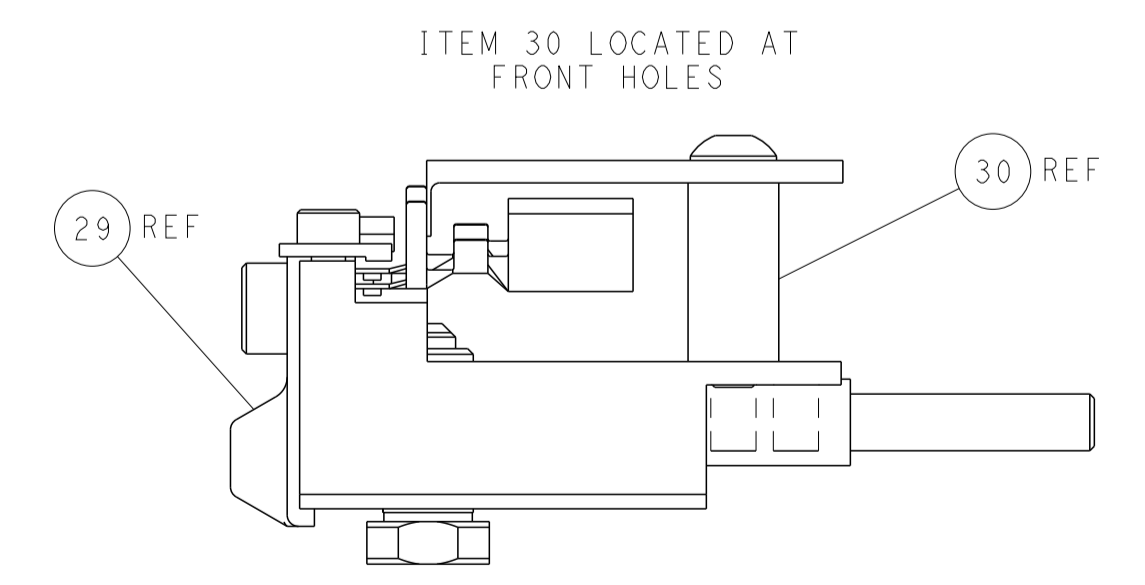

FEED TRACK POSITION
GUIDE BY INSULATION BARREL

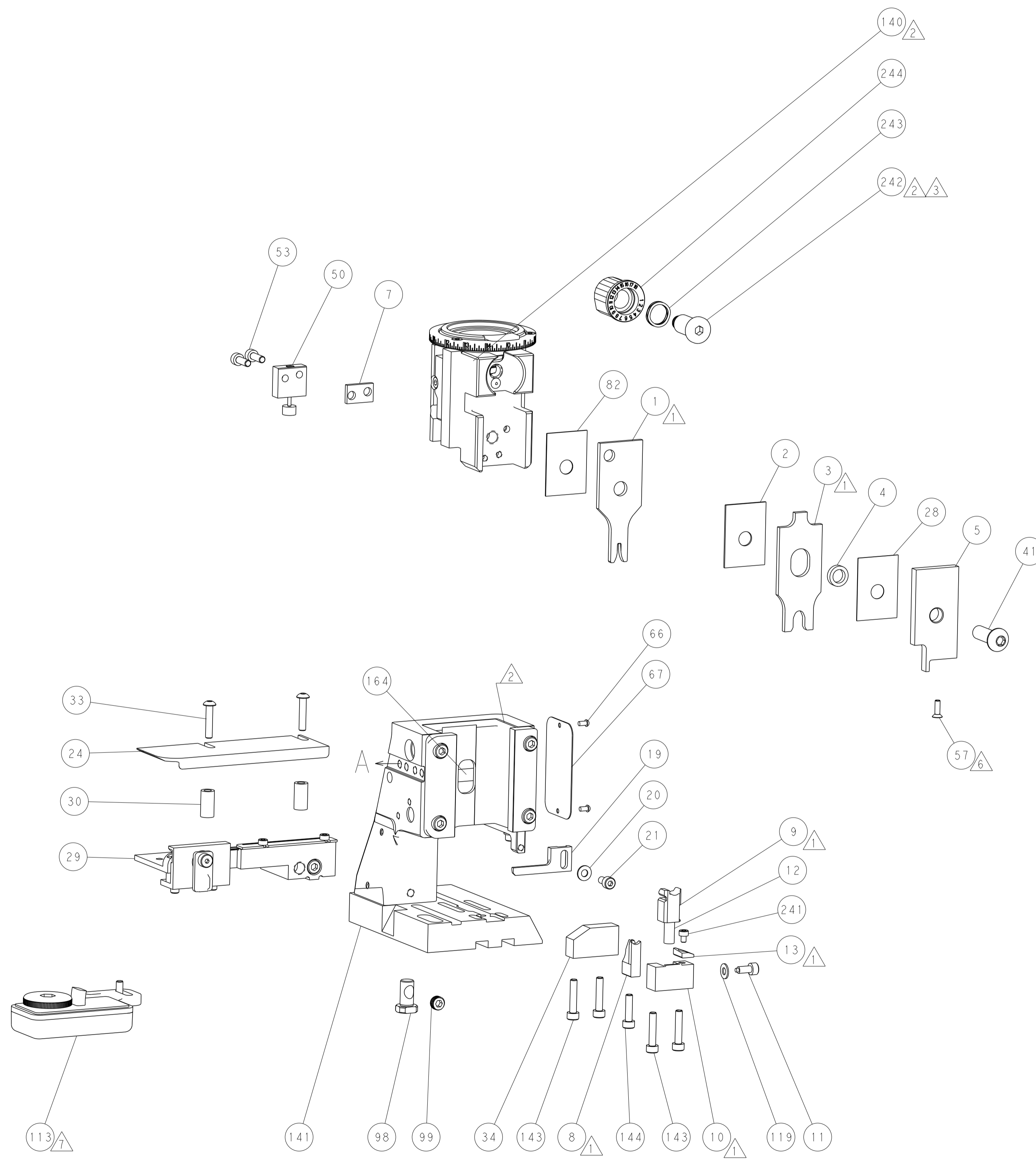

CAM POSITION

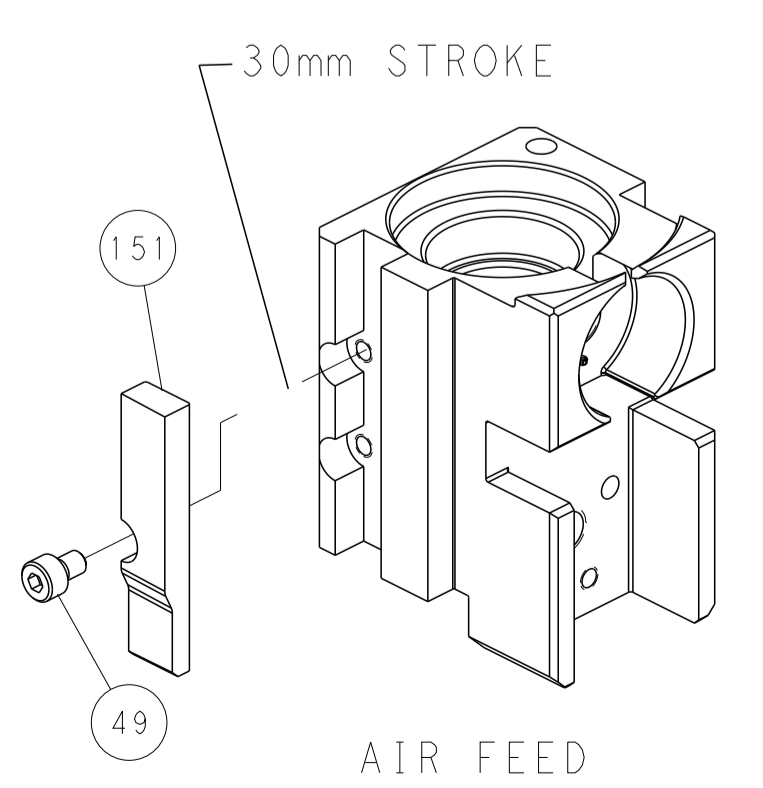

AIR FEED

PACIFIC VERSION
 Shown on sheets 3 of 4 & 4 of 4
 (Atlantic version shown on sheets 1 of 4 & 2 of 4)

DIMENSIONS:		TOLERANCES UNLESS OTHERWISE SPECIFIED:		DWG L. ZHANG 22SEP2011		CHK L. ZHANG 22SEP2011		NAME		STE TE Connectivity Harrisburg, PA 17105-3608	
mm	0 PLC ±	1 PLC ±	2 PLC ±	3 PLC ±	4 PLC ±	APVD S. XI 22SEP2011	PRODUCT SPEC	Ocean Side Feed Applicator		RESTRICTED TO	
MATERIAL	FINISH	WEIGHT	SCALE	1:2	SHEET 4 OF 4	REV G	Customer Accessible Production Drawing				