

Self-Closing Polyester Wrap

SCW-01

Description

NTE's self-closing wrap is a non-expandable sleeving woven from monofilament (weft) and multifilament (warp) polyester yarns. It is light weight, cost effective and abrasion resistant, and the split open design allows the sleeving to be easily installed on cable harnesses that have been assembled.

Applications

The self-closing wrap is most commonly used on wire harnesses and cable assemblies to provide a tough, durable protection in automotive, telecom, automatic equipment, railway and panel board equipment.

Features

- Material: Polyester Monofilament and Multifilament
- Operating Range: -50° to +150°C
- Melt Point: 240°C ±10°
- Flammability: DIN5510, BS6853
- Approved: RoHS, Halogen Free
- Color: Black, Grey, White, Orange
- Cutting Tool: Hot Knife

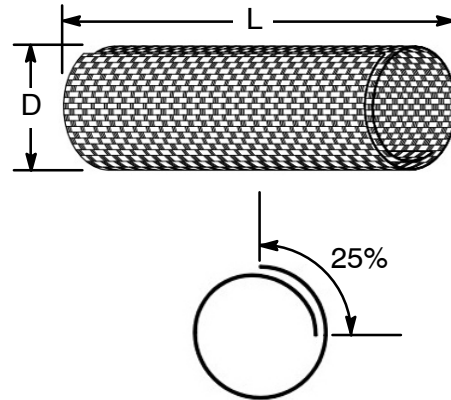

| NTE Type No. | (L) Feet per Roll | (D) Inner Diameter (in. / mm) | Max Diameter (in. / mm) |
|---------------|-------------------|-------------------------------|-------------------------|
| 04-SCW5C-XX | 100 | .196 / 5 | .236 / 6 |
| 04-SCW5-10XX | 10 | .196 / 5 | .236 / 6 |
| 04-SCW10C-XX | 100 | .393 / 10 | .433 / 11 |
| 04-SCW10-10XX | 10 | .393 / 10 | .433 / 11 |
| 04-SCW13C-XX | 100 | .511 / 13 | .551 / 14 |
| 04-SCW13-10XX | 10 | .511 / 13 | .551 / 14 |
| 04-SCW19C-XX | 50 | .748 / 19 | .787 / 20 |
| 04-SCW19-10XX | 10 | .748 / 19 | .787 / 20 |
| 04-SCW25L-XX | 50 | .984 / 25 | 1.023 / 26 |
| 04-SCW25-10XX | 10 | .984 / 25 | 1.023 / 26 |
| 04-SCW32L-XX | 50 | 1.25 / 32 | 1.30 / 33 |
| 04-SCW32-10XX | 10 | 1.25 / 32 | 1.30 / 33 |
| 04-SCW38L-XX | 50 | 1.49 / 38 | 1.574 / 40 |
| 04-SCW38-10XX | 10 | 1.49 / 38 | 1.574 / 40 |
| 04-SCW50L-XX | 50 | 1.96 / 50 | 2.05 / 52 |
| 04-SCW50-10XX | 10 | 1.96 / 50 | 2.05 / 52 |

Note 1. Replace "X" in device number with GR = Gray, WH = White, OR = Orange, BK = Black.



Self-Closing Braided Wrap

SCBW-01

Description

NTE self-closing braided wrap offers innovative solutions for protection in breakout areas and is easy to remove when necessary for inspection and maintenance of cables. The special open structure allows the self-closing wrap to be installed after other components, including the copper terminals and connectors.

Applications

The self-closing braided wrap is ideal for use in wire harnesses, automatic equipment, railways, and general manufacturing industries where wires and tubes need a strong and durable protection.

Features

- Material: Polyester
- Operating Range: -50° to $+150^{\circ}\text{C}$
- Melt Point: $240^{\circ}\text{C} \pm 10^{\circ}$
- Flammability: UL94-V2
- Approved: RoHS, Halogen Free
- Color: Black, Grey, White, Orange
- Cutting Tool: Hot Knife / Scissors

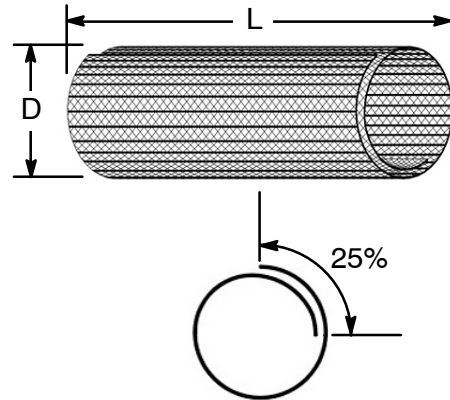

| NTE Type No. | (L) Feet per Roll | (D) Inner Diameter (in. / mm) | Max Diameter (in. / mm) |
|----------------|-------------------|-------------------------------|-------------------------|
| 04-SCBW6C-XX | 100 | .236 / 6 | .276 / 7 |
| 04-SCBW6-10XX | 10 | .236 / 6 | .276 / 7 |
| 04-SCBW9C-XX | 100 | .354 / 9 | .393 / 10 |
| 04-SCBW9-10XX | 10 | .354 / 9 | .393 / 10 |
| 04-SCBW13C-XX | 100 | .511 / 13 | .551 / 14 |
| 04-SCBW13-10XX | 10 | .511 / 13 | .551 / 14 |
| 04-SCBW19L-XX | 50 | .748 / 19 | .787 / 20 |
| 04-SCBW19-10XX | 10 | .748 / 19 | .787 / 20 |
| 04-SCBW25L-XX | 50 | .984 / 25 | 1.023 / 26 |
| 04-SCBW25-10XX | 10 | .984 / 25 | 1.023 / 26 |
| 04-SCBW32L-XX | 50 | 1.25 / 32 | 1.30 / 33 |
| 04-SCBW32-10XX | 10 | 1.25 / 32 | 1.30 / 33 |
| 04-SCBW38L-XX | 50 | 1.49 / 38 | 1.574 / 40 |
| 04-SCBW38-10XX | 10 | 1.49 / 38 | 1.574 / 40 |
| 04-SCBW50L-XX | 50 | 1.96 / 50 | 2.05 / 52 |
| 04-SCBW50-10XX | 10 | 1.96 / 50 | 2.05 / 52 |

Note 1. Replace "X" in device number with GR = Gray, WH = White, OR = Orange, BK = Black.

