



SPECIFICATION SHEET

SPECIFICATION SHEET NO.	Q0630-CD4M000000S001
DATE	June 30, 2023
REVISION	A4
DESCRIPTION	<p>Thru-Hole Ceramic Resonator, L9.5*W4.0*H6.0mm, 3 Pins Lead: 13.5mm 4.00000MHz, Built-in Capacitance, 30pF, CRTWS Series Frequency Accuracy $\pm 0.5\%$, Operating Temp. Range $-40^{\circ}\text{C} \sim +85^{\circ}\text{C}$ RoHS3 EU Directive 2011/65/EU 2015/863 The 233 Substances of Very High Concern, as specified by Regulation (EC) No.1907/2006 (REACH). 2000pcs/Paper Tape, Packed in Tape Box</p>
CUSTOMER	
CUSTOMER PART NUMBER	
CROSS REF. PART NUMBER	
ORIGINAL PART NUMBER	TGS CRTWS 4.0MGTLF
PART CODE	CD4M000000S001

VENDOR APPROVE			
Issued/Checked/Approved			
DATE: June 30, 2023			

CUSTOMER APPROVE	
DATE:	

6/30/2023

MHZ THRU-HOLE CERAMIC RESONATOR CRTWS SERIES

MAIN FEATURE



- MHz Thru-Hole Ceramic Resonator, L9.5*W4.0*H6.0mm, 3 pins
- Low cost, Built-in load capacitance type.
- Cross more competitors part
- RoHS3 EU Directive 2011/65/EU 2015/863
- The 233 Substances of Very High Concern, as specified by Regulation (EC) No.1907/2006 (REACH).

APPLICATION

- Measurement Instrument
- Communication Electronics

PART CODE GUIDE

RFQ
Request For Quotation

CD	4M000000	S	001
1	2	3	4

- 1) CD: Part family Code for MHz Thru-Hole Ceramic Resonator, L9.5*W4.0*H6.0mm, 3 Pins , CRTWS series
- 2) 4M000000: Frequency range code for 4.00000MHz
- 3) S: Package code: 2000pcs/Tape Box
- 4) 001: Internal control code Number + Letter (0~9 or A~Z)

MHZ THRU-HOLE CERAMIC RESONATOR CRTWS SERIES

DIMENSION (Unit: mm)

Image for reference

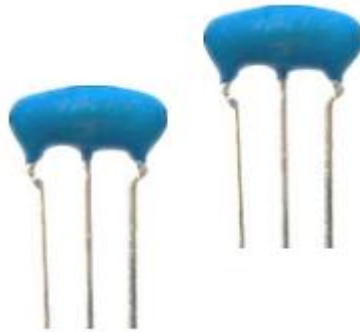

CRTWS

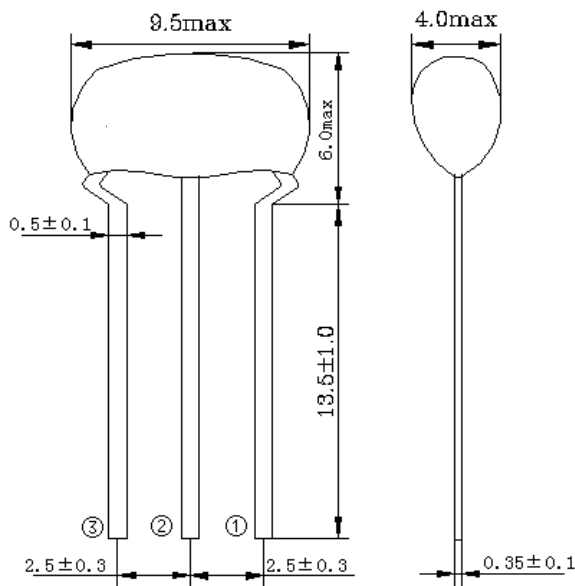

Marking

Frequency Range + QC Code/stamp

Connection

① Input ② Ground ③ Output

Structure

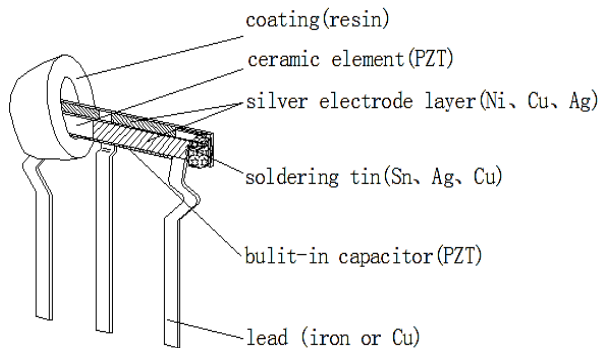

MHZ THRU-HOLE CERAMIC RESONATOR CRTWS SERIES
ELECTRICAL PARAMETERS

Parameter	Part No. Symbol	Units	Value			Condition
			Min.	Typical	Max.	
Original Manufacturer	TGS	TGS Crystals				
Holder Type	CRTWS	MHz Thru-Hole Ceramic Resonator L9.5*W4.0*H6.0mm, 3 Pins Lead: 13.5mm				
Frequency Range	4.0	MHz	4.00000			
Withstanding Voltage	MG	V	50		@DC, 1 min	
Insulation Resistance		MΩ	100		@100V, 1 min.	
Operation Temperature		°C	-40		+85	
Storage Temperature		°C	-55		+85	
Rating Voltage		V	10		DC	
			20		p-p	
Frequency Accuracy		%	±0.5			
Resonant Impedance		Ω			20	
Temperature Coefficient of Oscillation Frequency		%			±0.3	Oscillation Frequency drift, -40°C ~ +85°C)
Oscillation Frequency Aging Rate (10 years)		%			±0.3	From initial value
IC Application		1/6 TC4069UBPx2				
Design Mode						
Built-in Capacitance (C1,C2)	pF	30pF±20%				
Other	Package	T	2000pcs/Tape Box			
	RoHS Status	LF	RoHS3 EU Directive 2011/65/EU 2015/863			
	Add Value		N/A			
	Internal Control Code		Specification vision Code or Blank: N/A			

Note: 1) Original Part No.: TGS CRTWS 4.0MG TLF 2) Components shall be left in a chamber of +85±2°C for 1000 hours, then measured after leaving in natural condition for 1 hour.

6/30/2023

MHZ THRU-HOLE CERAMIC RESONATOR CRTWS SERIES

RELIABILITY

Test Items	Test Method And Conditions	Performance Requirements
Humidity	Subject the resonator at +60°C±2°C and 90%-95% R.H. for 1000h, resonator shall be measured after being placed in natural conditions for 1h.	It shall fulfill the specifications in Table 1.
High Temperature Exposure	Subject the resonator to +85°C±2°C for 1000h, resonator shall be measured after being placed in natural conditions for 1h.	It shall fulfill the specifications in Table 1.
Low Temperature Exposure	Subject the resonator to -40°C ± 3°C for 1000h, resonator shall be measured after being placed in natural conditions for 1h.	It shall fulfill the specifications in Table 1.
Temperature Cycling	After temperature cycling of blow table was performed 5 times, resonator shall be measured after being placed in natural conditions for 1h. Time: -30±3 min. @ -40 ± 3°C; Time: 30±3 min. @ +85 ± 3°C	It shall fulfill the specifications in Table 1.
Vibration	Subject the resonator to vibration for 2h each in x y and z axis with the amplitude of 1.5mm, the frequency shall be varied uniformly between the limits of 10Hz-55Hz and then resonator shall be measured.	It shall fulfill the specifications in Table 1.
Mechanical Shock	Resonator shall be measured after 3 times random dropping from the height of 1m on concrete floor.	It shall fulfill the specifications in Table 1.
Resistance to Soldering Heat	Lead terminals are immersed up to 2 mm from resonator's body in soldering bath of 260°C±5°C for 10s±1s and then resonator shall be measured after being placed in natural conditions for 1h.	It shall fulfill the specifications in Table 1.
Solderability	With Rosin-methanol 25% by weight, dip in 230°C±5°C solder(H63A) bath for 3s±0.5s.	More than 95% of the terminal surface of the filter shall be covered with fresh solder.
Terminal Strength Pulling, Bending	Force of 5N is applied to each lead in axial direction for 10s±1s. When force of 5N is applied to each lead in axial direction, the lead shall folded up 90° from the axial direction and folded back to the axial direction. The speed of folding shall be each 3s.	No visible damage and it shall fulfill Table 1.

MHZ THRU-HOLE CERAMIC RESONATOR CRTWS SERIES

Table 1

Item	Specification after test
Oscillation Frequency Change $\Delta F_{osc}/F_{osc}$ (%) max	± 0.3 (Refer to the initial value)
Resonant Impedance (Ω) max	20
The limits in the above table are referenced to the initial measurements.	

TEST CIRCUIT (For Reference Only)

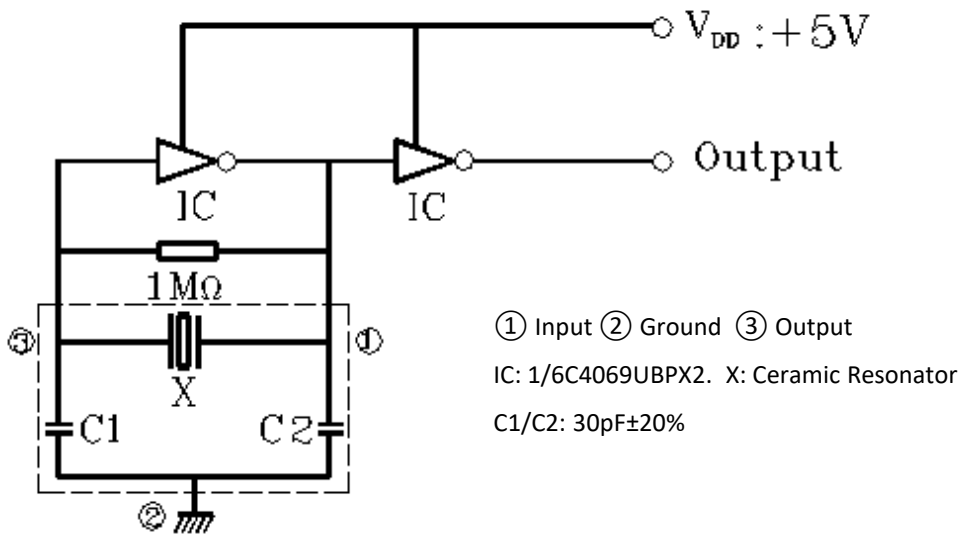

Note:

- Parts shall be tested under the condition (Temp.: 20 \pm 15 $^{\circ}$ C, Humidity 65 \pm 20% R.H.) unless the standard Condition (Temp.: 25 \pm 2 $^{\circ}$ C, Humidity :65 \pm 5% R.H.) is regulated to measure.

MHZ THRU-HOLE CERAMIC RESONATOR CRTWS SERIES

TAPE (Unit: mm)

All Devices are packed in accordance with EIA standard RS-481-2 and 2000pcs Packed in Tape Box

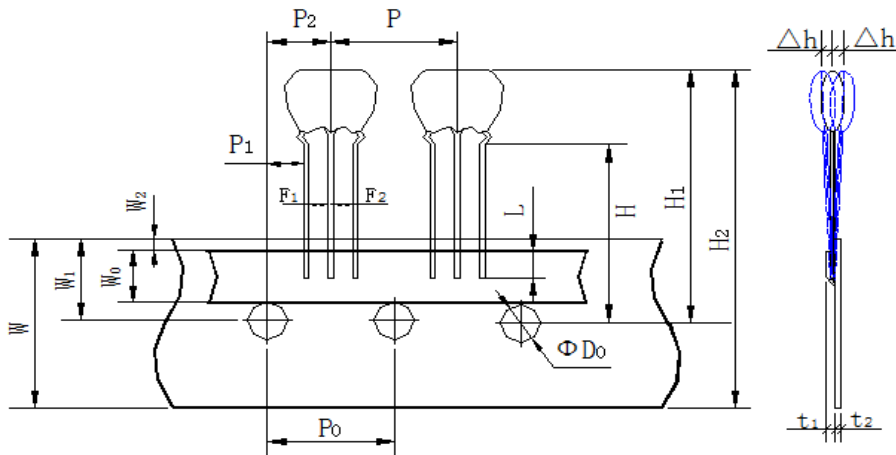

MARK	SIZE(mm)
P	12.7±0.5
Po	12.7±0.2
P1	3.85±0.5
P2	6.35±1.30 (include the slant of product)
F1	2.5±0.3
F2	2.5±0.3
Wo	5.5±0.5
W1	9.0±0.5
W2 max.	1.0
W	18.0±0.5
H	18.0 +0.5 (-1.0)
H1	27.0 max. (Varies with P/N)
H2	36.0 max. (Varies with P/N)
L min.	3.0
ΦDo	4.0±0.2
t1	0.6±0.2
t2 max	1.5
Δh max.	1.0

MHZ THRU-HOLE CERAMIC RESONATOR CRTWS SERIES

PACKAGE - TAPE BOX

- Parts shall be packaged in box with hold down tape upside. Part No., quantity and lot No.
- Leader Tape: More than 300mm leader tape with no products shall be provided at both end of the tape.
- Packing Style: Tape is folded at every 25 pitches in zigzag way, and contained in the box. Steel sticks are inserted the third hole from both edge of the tape. Those are used to keep steady state. Shock absorber or paper board shall be placed between products and box.
- Packing Quantity: 2000pcs are contained in box.

STIPULATION OF PRODUCTS ALIGNMENT

- Dropout of parts shall be confined to no more than 3 continuous parts.
- Dropout of parts on a reel shall be less than 0.25% of net quantity.
- All products shall face their marking side toward the hold down tape. (Upward in the figure below in this page)
- Tape Connection:

- 1) in the case of a carrier tape running out, Connect the back face of tapes together with a adhesive tape. Total thickness of tape 1.05mm max.

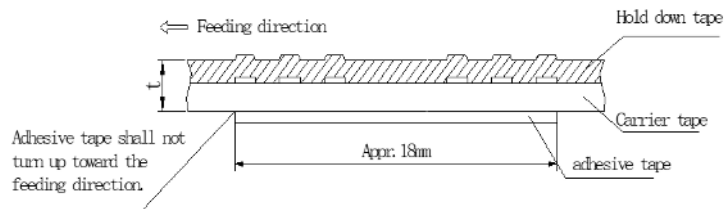

- 2) In the case of a hold down tape running out, Overlap the hold down tape for connection. Total thickness of tape 1.05mm max.

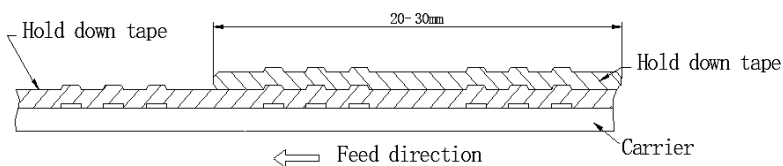

- 3) In the case of connecting both carrier tape and hold down tape. Connect both carrier tape and hold down tape together with adhesive tape.

MHZ THRU-HOLE CERAMIC RESONATOR CRTWS SERIES

OTHERS:

- Caution of use
- Do not clean or wash the component for it is not hermetically sealed.
- Don't be close to fire
- Don't apply excess mechanical stress to the component.
- Don't bend terminals of the component
- This specification mentions the quality of the component as a single unit. Please insure the component is thoroughly evaluated in your application circuit.
- Please return one of this specification after your signature of acceptance.
- When something gets doubtful with this specifications, we shall jointly work to get an agreement.

DISCLAIMER

NextGen Components, Inc. reserves the right to make changes to the product(s) and or information contained herein without notice. No liability is assumed as a result of their use or application. No rights under any patent accompany the sale of any such product(s) or information

6/30/2023