

Wide Vin, Multiple-Output DC/DC Converter and Power Path Manager

DESCRIPTION

Demonstration Circuit 1443A is a High Efficiency USB/Battery Power Manager plus multiple power converter featuring the LTC[®]3101.

The LTC3101 is a complete power management solution for low power portable devices. It provides three high efficiency switching DC/DC converters which seamlessly transition from battery to USB/Wall Adapter power when available. A synchronous buck-boost regulator provides complete flexibility, allowing operation from a single Li-Ion battery, 2-3 AA cells, a USB port, or any other power source from 1.8V to 5.5V. Two synchronous buck converters are available to provide independent outputs at up to 350mA each.

Two always-alive outputs, a 50mA LDO and a 200mA MAX output that tracks the higher voltage input supply, provide power for critical functions or additional external regulators. Flash memory cards can be directly powered from the protected 100mA hot-swap output. Pushbutton control logic and a programmable-duration microprocessor reset generator simplify interfacing to a microprocessor while internal sequencing and independent enable pins provide flexible power-up options.

Design files for this circuit board are available. Call the LTC factory.

LTC, LTM, LT, Burst Mode, are registered trademarks of Linear Technology Corporation. All other trademarks are the property of their respective owners.

TABLE 1. Typical Specifications (25°C)

Input Voltage Range: V _{CC}	1.8V to 5.5V
V _{OUT1}	1.5V, 350mA (Max) Buck
V _{OUT2}	1.8V, 350mA (Max) Buck
V _{OUT3}	3.3V, 300mA (Vin ≥ 1.8V), 800mA (Vin ≥ 3.0V), Buck-Boost
VLDO	1.8V, 50mA (Max) Linear Regulator
V _{MAX}	1.8-5.5V 200mA (MAX)
V _{HSC}	3.3V 100mA (MAX) HOT SWAP

QUICK START PROCEDURE

Using short twisted pair leads for any power connections and with all loads and power supplies off, refer to Figure 1 for the proper measurement and equipment setup. The Battery/Power Supply (PS) should not be connected to the circuit until told to do so in the procedure below.

When measuring the input or output voltage ripple, care must be taken to avoid a long ground lead on the oscilloscope probe. Measure the input or output voltage ripple by touching the probe tip directly across the VCC or VOUT and GND terminals. See Figure 2 for proper scope probe technique.

1. Jumper, PS and LOAD Settings to start:

JP1 (ENA1) = OFF	PS1 = OFF
JP2 (ENA2) = OFF	PS2 = OFF
JP3 (ENA3) = OFF	LOAD1 = 350mA
JP4 (PWRON) = BUTTON	LOAD2 = 350mA
JP5 (BURST) = PWM	LOAD3 = 300mA
	LOAD4 = 100mA
	LOAD5 = 50mA
	LOAD6 = 200mA

NC: Not Connected

- With all loads disconnected, or off, turn on PS1 and slowly increase voltage until the voltage at VBAT is 3.3V. Monitor input current. If input current exceeds 1.5mA turn off PS1 and look for shorts.
- Turn on LOAD5 and LOAD6. Set LOAD5 on LDO to 50mA and LOAD6 on VMAX to 200mA.
- Verify the DC voltage levels on LDO as ~1.8V, VMAX as ~3.3V and BAT as ~3.3V.
- Set LOAD1 to 350mA. Move the jumper on JP1 (ENA1) to ON. Turn ON the converter by pushing S1. Verify VOUT1 is ~1.5V.

NOTE: PCB Silkscreen on VOUT1 & VOUT2 is labeled 250mA, the outputs have been enhanced to provide 350mA as stated in the QSG.
- Set LOAD2 to 350mA. Move the jumper on JP2 (ENA2) to ON. Verify VOUT2 is ~1.8V.
- Set LOAD3 to 300mA. Move the jumper on JP3 (ENA3) to ON. Verify VOUT3 is ~3.3V.
- Set LOAD4 to 100mA. Verify VHSC is ~3.3V.
- PS1 can be varied between 1.8V and 5.5V.

Note: With VBAT below 3V the load on VOUT3 should be 300mA or less. Once VBAT exceeds 3V, the VOUT3 load can be increased up to 800mA. Also, with BAT below approximately 2.0V, LDO and VOUT2 will eventually drop out of regulation since they are set to regulate at 1.8V.
- A second supply can be connected to the USB INPUT, J1. This allows the user to operate from the higher of the two inputs, VBAT or USB. Switch over between the supplies is automatic.
- For start-up at 1.8V or to allow turn-on automatically with VBAT>UVLO threshold, move jumper on JP4 (PWRON) to ON.

LTC3101EUFE

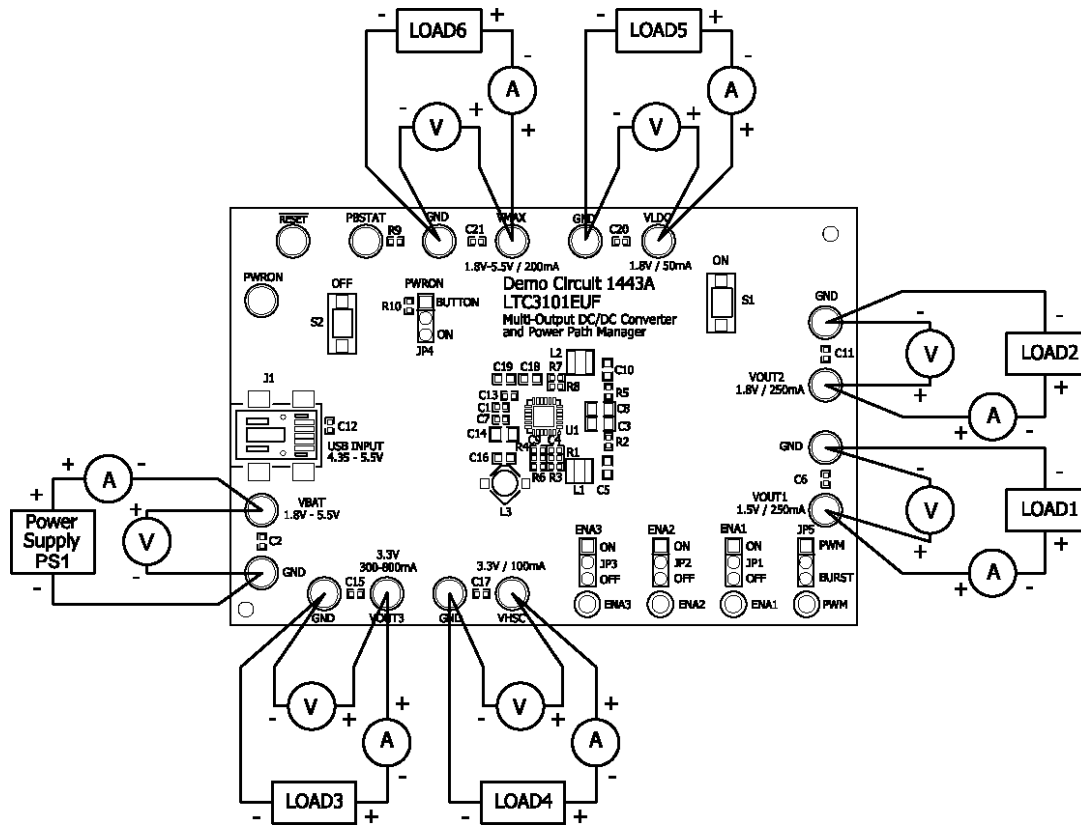

Figure 1. Proper Measurement Equipment Setup

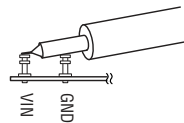

Figure 2. Measuring Input or Output Ripple

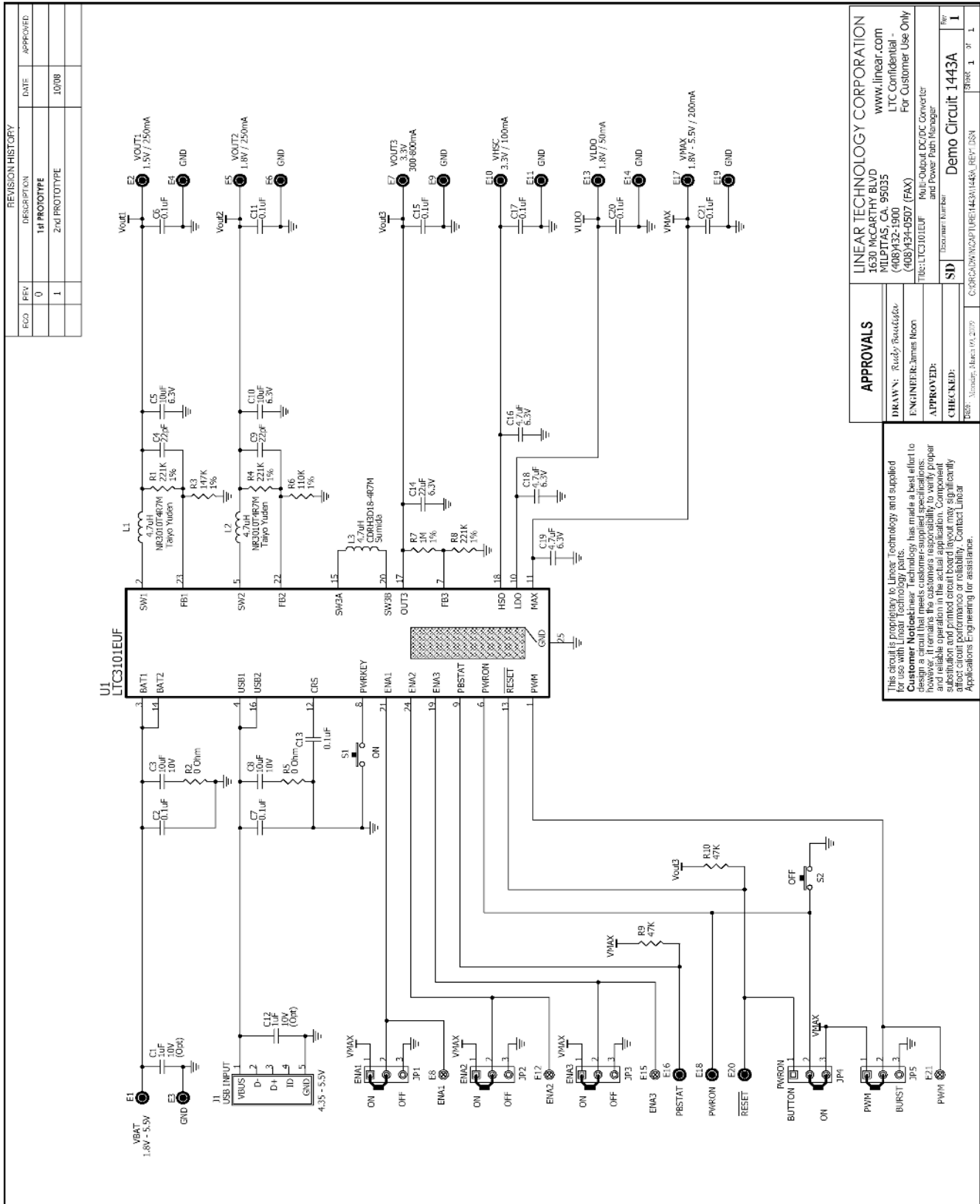

Figure 3. Circuit Schematic

APPROVALS	
DRAWN BY: <i>Rudolf Bauckhals</i>	www.linear.com
ENGINEERED BY: James Hoon	LTC Confidential - For Customer Use Only
APPROVED:	FILE: LTC3101EUF
CHECKED:	Rev: 1
DATE: 10/08	Part Number: Demo Circuit 1443A
DESIGNER: [Signature]	REVISION: 1

This circuit is proprietary to Linear Technology and supplied for use with Linear Technology parts. Linear Technology has made a best effort to design a circuit that meets customer-supplied specifications; however, it remains the customer's responsibility to verify proper and reliable operation in the actual application. Component substitution and printed circuit board layout may significantly affect circuit performance or reliability. Contact Linear Applications Engineering for assistance.

Item	Quantity	Reference	Part	Manufacturer, Part Number
Circuit Components				
1	9	C2,C6,C7,C11,C13,C15,C17, C20,C21	Cap., X5R 0.1uF 16V 20% 0402	AVX 0402YD104MAT2A
2	2	C3,C8	Cap., X5R 10uF 10V 20% 0805	Taiyo Yuden LMK212BJ106MG
3	2	C4,C9	Cap., NPO 22pF 25V 10% 0402	AVX 04023A220KAT2A
4	2	C5,C10	Cap., X5R 10uF 6.3V 20% 0603	TDK C1608X5R0J106M
5	1	C14	Cap., X5R 22uF 6.3V 20% 0805	TDK C2012X5R0J226M
6	3	C16,C18,C19	Cap., X5R 4.7uF 6.3V 20% 0603	TDK C1608X5R0J475M
7	2	L1,L2	Inductor, 4.7uH	Taiyo Yuden NR3010T4R7M
8	1	L3	Inductor, 4.7uH	Sumida CDRH3D18-4R7M
9	3	R1,R4,R8	Res., Chip 221K 0.06W 1% 0402	Vishay CRCW0402221KFKED
10	2	R2,R5	Res/Jumper, Chip 0 Ohm 1/16W 1 AMP 0402	Vishay CRCW04020000ZOEAE
11	1	R3	Res., Chip 147K 0.06W 1% 0402	Vishay CRCW0402147KFKED
12	1	R6	Res., Chip 110K 0.06W 1% 0402	Vishay CRCW0402110KFKED
13	1	R7	Res., Chip 1M 0.06W 1% 0402	Vishay CRCW04021M00FKED
14	2	R10,R9	Res., Chip 47K 0.06W 5% 0402	Vishay CRCW040247K0JNED
15	1	U1	I.C., Linear Regulator QFN(24)(UF)4MMX4MM	Linear Tech. Corp. LTC3101EUF
OPTIONAL COMPONENTS FOR DEMO BOARD				
1	0	C1,C12 (Opt)	Cap., X5R 1uF 10V 20% 0402	AVX 0402ZD105MAT2A
HARDWARE FOR DEMO BOARD ONLY				
1	1	J1	Connector, USB Mini-A	Tyco Electronics 440247-1
2	2	S1,S2	SWITCH, Push Button EVQPS05K	Panasonic EVQPS05K
3	17	E1,E2,E3,E4,E5,E6,E7,E9, E10,E11,E13,E14,E16,E17, E18,E19,E20	Turret, Testpoint 0.094"	Mill Max 2501-2-00-80-00-00-07-0
	4	E8,E12,E15,E21	Turret, Testpoint 0.063"	Mill Max 2308-2-00-80-00-00-07-0
4	5	JP1,JP2,JP3,JP4,JP5	Headers, 3 Pins 2mm Ctrs.	Samtec TMM-103-02-L-S
16	5	XJP1,XJP2,XJP3,XJP4,XJP5	Shunt, 2mm Ctrs.	Samtec 2SN-BK-G

Figure 4. Bill of Materials