

FSA6157 Low- R_{ON} SPDT (0.8 Ω) Negative-Swing Audio or Video Switch

Features

- 0.8 Ω Typical On Resistance (R_{ON}) for +2.7V Supply
- 0.45 Ω Maximum R_{ON} Flatness for +2.7V Supply
- -3db Bandwidth: > 50MHz
- Low I_{CC} Current Over an Expanded Control Input Range
- Packaged in Pb-free 6-Lead MicroPak™ (1.0 x 1.4mm)
- Power-Off Protection on All I/O Ports
- Broad V_{CC} Operating Range: 1.65 to 4.3V
- HBM JEDEC: JESD22-A114
– I/O to GND: 12kV
- Power to GND: 16kV

Applications

- Cell Phone, PDA, Digital Camera, and Notebook
- LCD Monitor, TV, and Set-top Box

Description

The FSA6157 is a high-performance, Single Pole Double Throw (SPDT) analog switch that features a low R_{ON} of 0.8 Ω (typical) at 2.7V supply. The FSA6157 operates over a wide V_{CC} range of 1.65V to 4.3V and is designed for break-before-make operation. The select input is TTL-level compatible.

The FSA6157 features very low quiescent current even when the control voltage is lower than the V_{CC} supply. This feature suits mobile handset applications by allowing direct interface with baseband processor general-purpose I/Os with minimal battery consumption.

IMPORTANT NOTE:

For additional performance information, please contact analogswitch@fairchildsemi.com.

Ordering Information

Part Number	Top Mark	 Eco Status	Package Description
FSA6157L6X	GT	Green	6-Lead, MicroPak™, 1.0mm wide, JEDEC MO-255

 For Fairchild's definition of Eco Status, please visit: http://www.fairchildsemi.com/company/green/rohs_green.html.

Analog Symbol

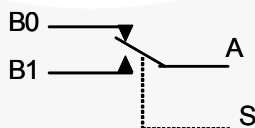

Figure 1. FSA6157

Pin Assignments

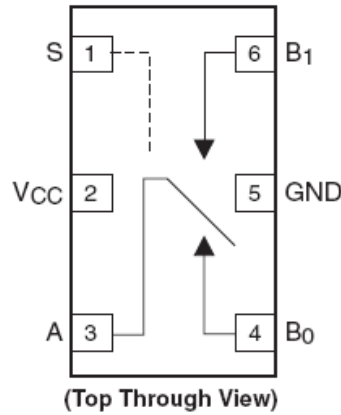

Figure 2. Pin Assignments for 6-Lead MicroPak™

Pin Descriptions

Name	Description
A, B ₀ , B ₁	Data Ports
S	Switch Select Pin

Truth Table

Control Input, S	Function
LOW	B ₀ connected to A
HIGH	B ₁ connected to A

Absolute Maximum Ratings

Stresses exceeding the absolute maximum ratings may damage the device. The device may not function or be operable above the recommended operating conditions and stressing the parts to these levels is not recommended. In addition, extended exposure to stresses above the recommended operating conditions may affect device reliability. The absolute maximum ratings are stress ratings only.

Symbol	Parameter		Min.	Max.	Units
V _{CC}	Supply Voltage		-0.5	4.6	V
V _{SW}	Switch I/O Voltage ⁽¹⁾	B0, B1, A Pins	V _{CC} - 5.5V	4.6	V
V _{SW-SW}	Switch I/O to Switch I/O Voltage Delta (Off State) ⁽¹⁾	B0, B1, A Pins		5.5	V
V _{CNTRL}	Control Input Voltage ⁽¹⁾	S	-0.5	4.6	V
I _{IK}	Input Clamp Diode Current			-50	mA
I _{SW}	Switch I/O Current (Continuous)			350	mA
I _{SWPEAK}	Peak Switch Current (Pulsed at 1ms Duration, <10% Duty Cycle)			500	mA
T _{STG}	Storage Temperature Range		-65	+150	°C
T _J	Maximum Junction Temperature			+150	°C
T _L	Lead Temperature (Soldering, 10 seconds)			+260	°C
ESD	Human Body Model (JEDEC: JESD22-A114)	I/O to GND		12	kV
		Power to GND		16	
		All Other Pins		8	
	Charge Device Model (JEDEC: JESD22-C101)				2

Note:

1. Input and output negative ratings may be exceeded if input and output diode current ratings are observed.

Recommended Operating Conditions

The Recommended Operating Conditions table defines the conditions for actual device operation. Recommended operating conditions are specified to ensure optimal performance to the datasheet specifications. Fairchild does not recommend exceeding them or designing to absolute maximum ratings.

Symbol	Parameter	Min.	Max.	Units
V _{CC}	Supply Voltage	1.65	4.3	V
V _{CNTRL} ⁽²⁾	Control Input Voltage – Select Pin	0	V _{CC}	V
V _{SW}	Switch I/O Voltage	V _{CC} - 4.3V	4.3	V
V _{SW-SW}	Switch I/O Voltage to Switch I/O Voltage (Off-State)		4.6	V
T _A	Operating Temperature	-40	85	°C

Note:

2. Input and output negative ratings may be exceeded if input and output diode current ratings are observed.

DC Electrical Characteristics

All typical values are at 25°C unless otherwise specified.

Symbol	Parameter	Conditions	V _{CC} (V)	T _A =+25°C			T _A =-40 to +85°C		Unit	
				Min.	Typ.	Max.	Min.	Max.		
	Analog Signal Range			V _{CC} -4.3V		V _{CC}			V	
V _{IK}	Clamp Diode Voltage		3.00					-1.2	V	
V _{IH}	Input Voltage High		3.60 to 4.30				1.4		V	
			2.70 to 3.60				1.3			
			2.30 to 2.70				1.3			
			1.65 to 1.95				0.9			
V _{IL}	Input Voltage Low		3.60 to 4.30					0.7	V	
			2.70 to 3.60					0.4		
			2.30 to 2.70					0.4		
			1.65 to 1.95					0.4		
I _{IN}	Control Input Leakage (S)	V _{IN} =0 to V _{CC}	4.30				-1	1	μA	
I _{NO(OFF)} , I _{NC(OFF)}	Off Leakage Current of Port B0 and B1	A=0.5V, V _{CC} - 0.5V B0 or B1=V _{CC} - 0.5V, 0.5V, or Floating; Figure 4	1.95 to 4.30	-100		100	-500	500	nA	
I _{A(ON)}	On Leakage Current of Port A	A=0.5V, V _{CC} - 0.5V B0 or B1=V _{CC} -0.5V, 0.5V, or Floating; Figure 5	4.30	-100		100	-250	250	nA	
I _{OFF}	Power-Off Leakage Current (All I/O Ports)	V _{A,BN} =0.3V to 4.3V or Floating,	0V or Floating				-40	40	μA	
R _{ON}	Switch On Resistance ^(3,6)		I _{ON} =100mA, B0 or B1=0, 0.7V, 3.6V, 4.3V; Figure 3	4.30		0.4			0.8	Ω
			I _{ON} =100mA, B0 or B1=0, 0.7V, 2.0V, 2.7V; Figure 3	2.70		0.8			1.0	
			I _{ON} =100mA, B0 or B1=0, 0.7V, 1.6V, 2.3V; Figure 3	2.30					1.5	
			I _{ON} =100mA, B0 or B1=0, 0.7V, 1.65V; Figure 3	1.65		1.3			2.0	
ΔR _{ON}	On Resistance Matching Between Channels ⁽⁴⁾	I _{ON} =100mA, B0 or B1=0.7V	2.30 to 4.30		0.050			0.130	Ω	
R _{FLAT(ON)}	On Resistance Flatness ⁽⁵⁾	I _{OUT} =100mA, B0 or B1=0V to V _{CC}	2.70 to 4.30					0.45	Ω	
I _{CC}	Quiescent Supply Current	V _{SW} =0 or V _{CC} , I _{OUT} =0	4.30	-100		100	-500	500	nA	
I _{OCT}	Increase in I _{CC} per Input	Input at 2.6V	4.30		3.0			10.0	μA	
		Input at 1.8V			7.0					

Notes:

- On resistance is determined by the voltage drop between A and B pins at the indicated current through the switch.
- Δ R_{ON}=R_{ON max} - R_{ON min} measured at identical V_{CC}, temperature, and voltage.
- Flatness is defined as the difference between the maximum and minimum value of on resistance (R_{ON}) over the specified range of conditions.
- Guaranteed by characterization, not production tested.

AC Electrical Characteristics

All typical value are for V_{CC}=1.8V, 2.5V, 3.3V, and 4.0V at 25°C unless otherwise specified.

Symbol	Parameter	Conditions	V _{CC} (V)	T _A =+25°C			T _A =-40 to +85°C		Unit	Figure
				Min.	Typ.	Max.	Min.	Max.		
t _{ON}	Turn-On Time	B0 or B1=1.0V, R _L =50Ω, C _L =35pF	3.60 to 4.30	5		65	3	70	ns	Figure 6 Figure 7
			2.70 to 3.60	5		65	3	70		
			2.30 to 2.70	5		70	3	80		
			1.65 to 1.95	10		100	10	150		
t _{OFF}	Turn-Off Time	B0 or B1=1.0V, R _L =50Ω, C _L =35pF	3.60 to 4.30	1		35	1	45	ns	Figure 6 Figure 7
			2.70 to 3.60	1		35	1	45		
			2.30 to 2.70	2		45	2	50		
			1.65 to 1.95	2		70	2	95		
t _{BBM}	Break-Before-Make Time	B0 or B1=1.0V, R _L =50Ω, C _L =35pF	3.60 to 4.30				2		ns	Figure 8
			2.70 to 3.60				2			
			2.30 to 2.70				2			
			1.65 to 1.95				2			
Q	Charge Injection	C _L =1.0nF, V _S =0V, R _S =0Ω	3.60 to 4.30		25				pC	Figure 12
			2.70 to 3.60		15					
			2.30 to 2.70		12					
			1.65 to 1.95		5					
OIRR	Off Isolation	f=20kHz, R _L =50Ω, C _L =0pF	1.65 to 4.30		-60				dB	Figure 10
Xtalk	Crosstalk	f=20kHz, R _L =50Ω, C _L =0pF	1.65 to 4.30		-60				dB	Figure 11
BW	-3db Bandwidth	R _L =50Ω, C _L =0pF	1.65 to 4.30		>50				MHz	Figure 9
THD	Total Harmonic Distortion	f=20Hz to 20kHz, R _L =32Ω, V _{IN} =2V _{PP}	1.65 to 4.30		0.1				%	Figure 15
SNR	Signal to Noise Ratio	f=1kHz, R _L =32Ω, V _{IN} =0dBm, V _{BIAS} =0V	4.30		-70				dB	

Capacitance

Symbol	Parameter	Conditions	V _{CC} (V)	T _A =+25°C			Unit	Figure
				Min.	Typ.	Max.		
C _{IN}	Control Pin Input Capacitance	f=1MHz	0		3		pF	Figure 13
C _{OFF}	B Port Off Capacitance	f=1MHz	3.30			30	pF	Figure 13
C _{ON}	A Port On Capacitance	f=1MHz	3.30			150	pF	Figure 14

Test Diagrams

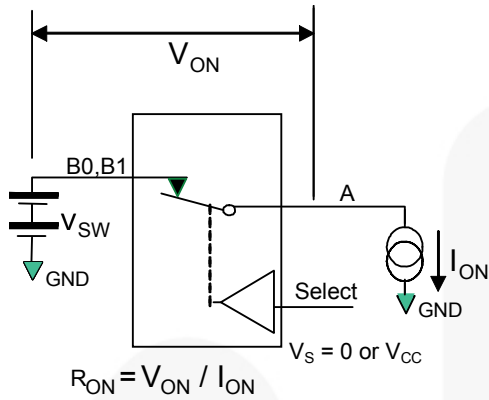

Figure 3. On Resistance

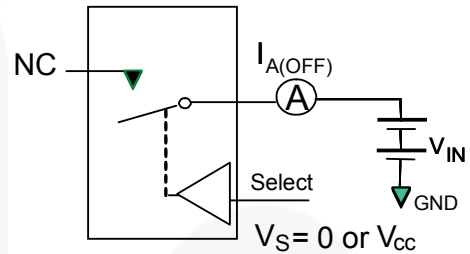

Figure 4. Off Leakage (Ports Tested Separately)

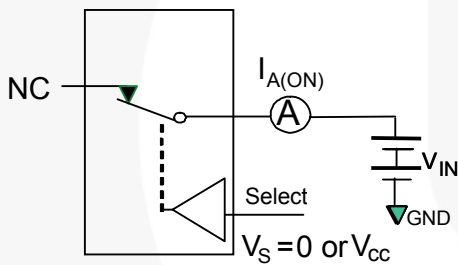

Figure 5. On Leakage

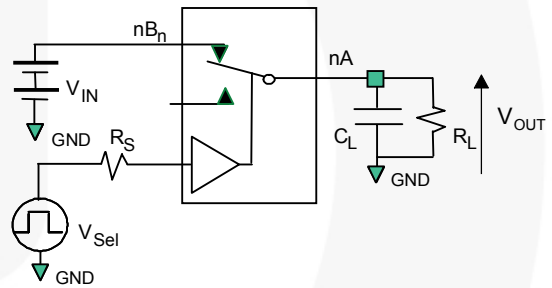

Figure 6. Test Circuit Load

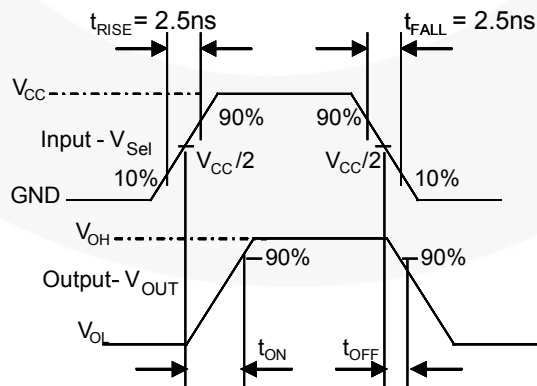

Figure 7. Turn-On / Turn-Off Waveforms

Test Diagrams (Continued)

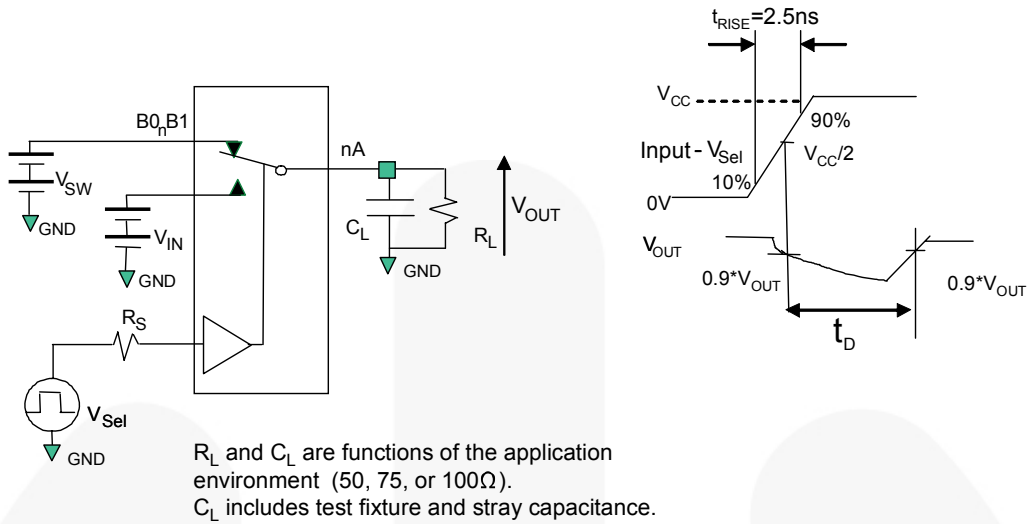

Figure 8. Break-Before-Make Interval Timing

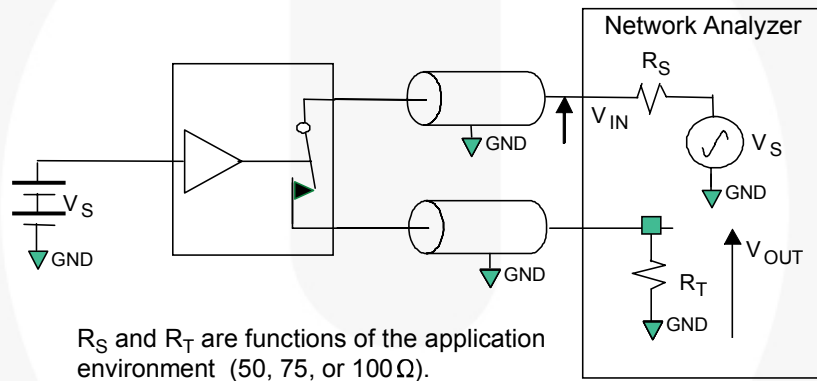

Figure 9. Bandwidth

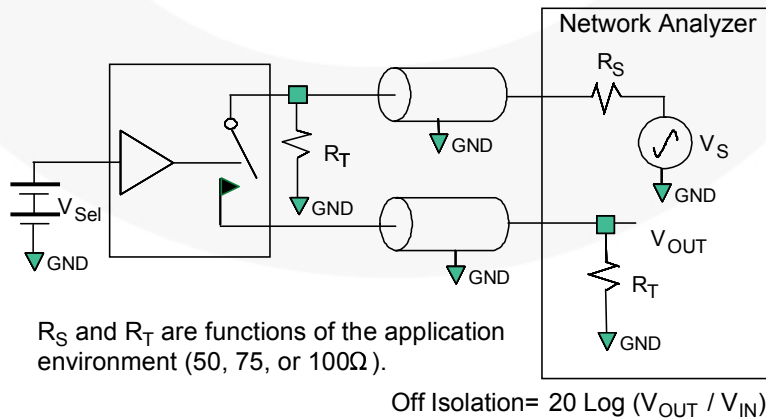

Figure 10. Channel Off Isolation

Test Diagrams (Continued)

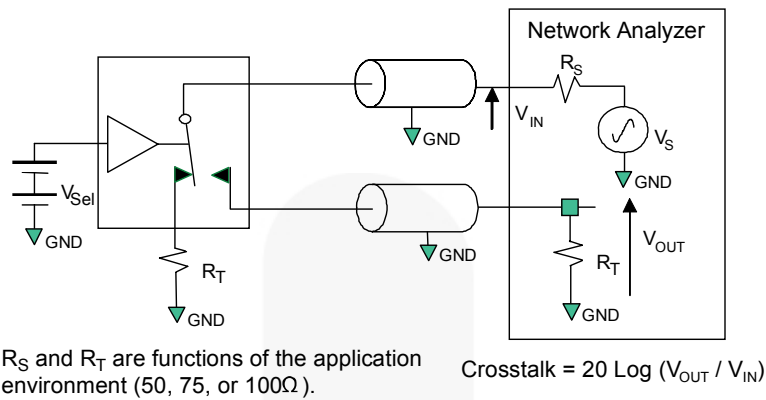

Figure 11. Adjacent Channel Crosstalk

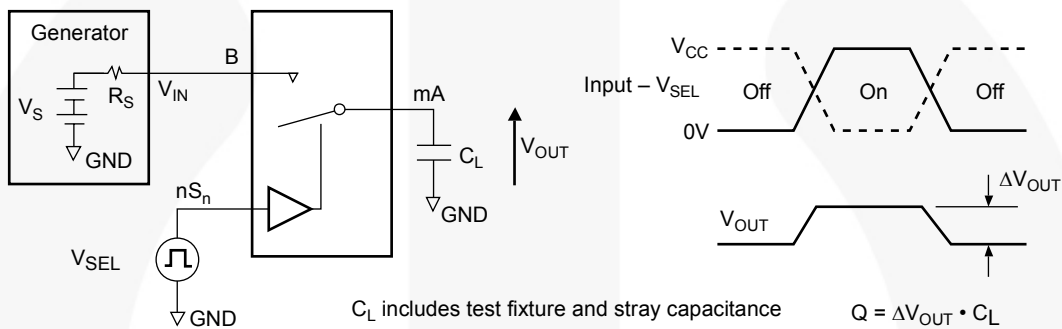

Figure 12. Charge Injection Test

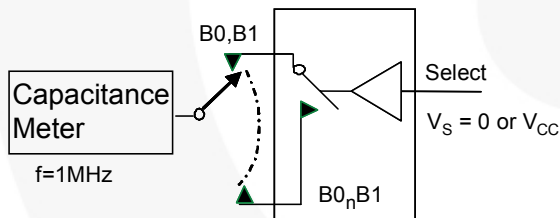

Figure 13. Channel Off Capacitance

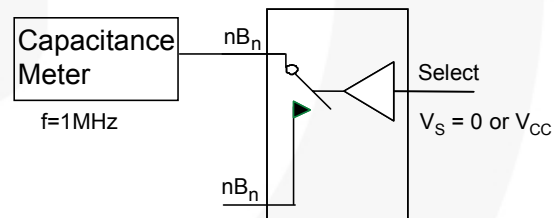

Figure 14. Channel On Capacitance

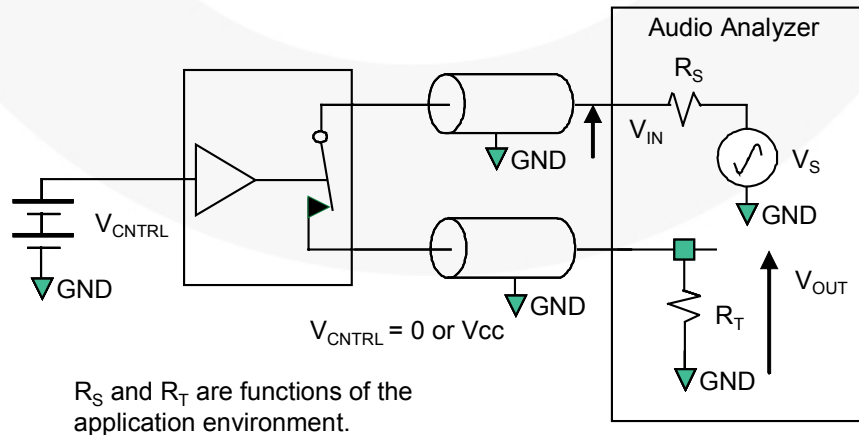
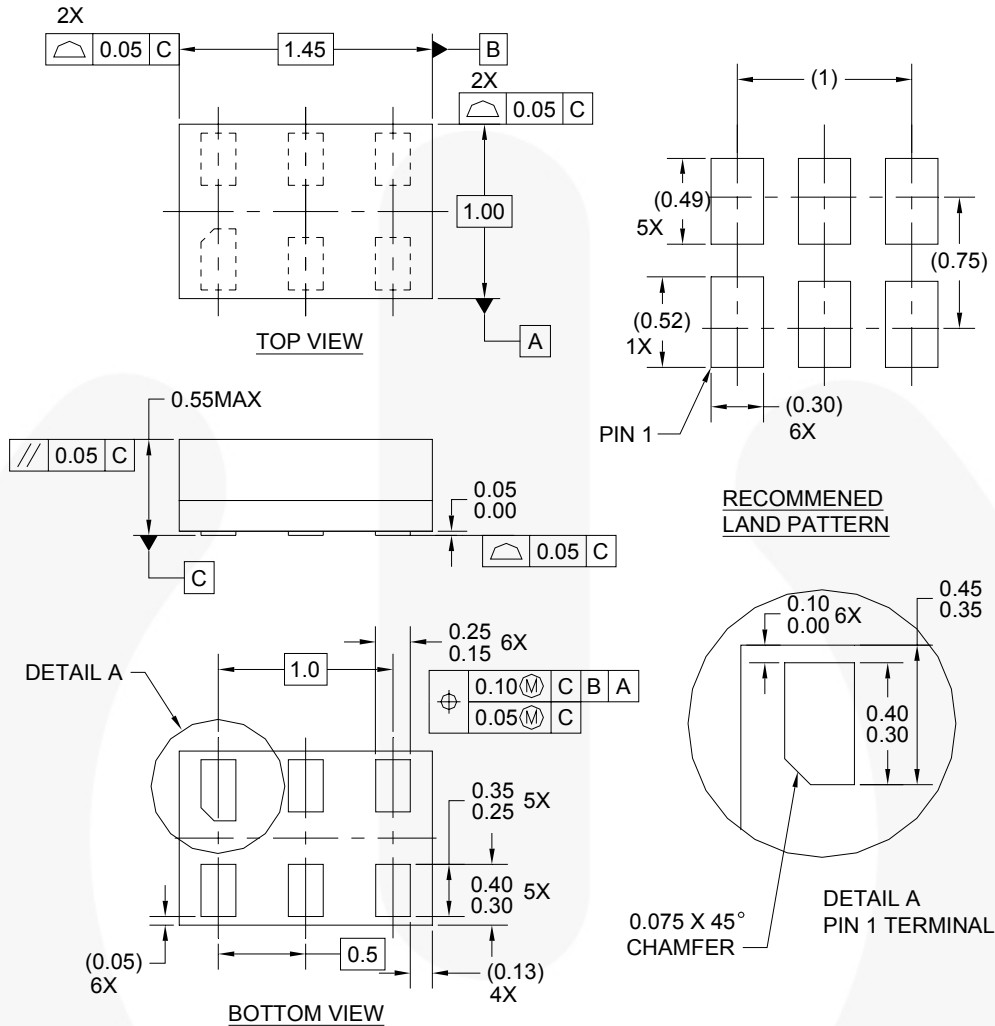

Figure 15. Total Harmonic Distortion

Physical Dimensions



MAC06AREVC

Figure 16. 6-Lead MicroPak™, 1.0mm Wide

Package drawings are provided as a service to customers considering Fairchild components. Drawings may change in any manner without notice. Please note the revision and/or date on the drawing and contact a Fairchild Semiconductor representative to verify or obtain the most recent revision. Package specifications do not expand the terms of Fairchild's worldwide terms and conditions, specifically the warranty therein, which covers Fairchild products.

Always visit Fairchild Semiconductor's online packaging area for the most recent package drawings:
<http://www.fairchildsemi.com/packaging/>.

For current tape and reel specifications, visit Fairchild Semiconductor's online packaging area:
http://www.fairchildsemi.com/products/logic/pdf/micropak_tr.pdf.



TRADEMARKS

The following includes registered and unregistered trademarks and service marks, owned by Fairchild Semiconductor and/or its global subsidiaries, and is not intended to be an exhaustive list of all such trademarks.

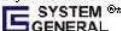
- | | | | |
|---|---|---|---|
| AccuPower™ | FPS™ | PowerTrench® | The Power Franchise® |
| Auto-SPM™ | F-PFS™ | PowerXS™ | the power franchise |
| Build it Now™ | FRFET® | Programmable Active Droop™ | TinyBoost™ |
| CorePLUS™ | Global Power Resource™ | QFET® | TinyBuck™ |
| CorePOWER™ | Green FPS™ | QST™ | TinyCalc™ |
| CROSSVOL7™ | Green FPS™ e-Series™ | Quiet Series™ | TinyLogic® |
| CTL™ | Gmax™ | RapidConfigure™ | TINYOPTO™ |
| Current Transfer Logic™ | GTO™ |  ™ | TinyPower™ |
| EcoSPARK® | IntelliMAX™ | Saving our world, 1mW/W/kW at a time™ | TinyPWM™ |
| EfficientMax™ | ISOPLANAR™ | SignalWise™ | TinyWire™ |
| EZSWITCH™ | MegaBuck™ | SmartMax™ | TinyWire™ |
|  | MICROCOUPLER™ | SMART START™ | TriFault Detect™ |
| Fairchild® | MicroFET™ | SPM® | TRUECURRENT™ |
| Fairchild Semiconductor® | MicroPak™ | STEALTH™ | µSerDes™ |
| FACT Quiet Series™ | MillerDrive™ | SuperFET™ |  |
| FACT™ | MotionMax™ | SuperSOT™-3 | UHC® |
| FAST® | Motion-SPM™ | SuperSOT™-6 | Ultra FRFET™ |
| FastvCore™ | OPTOLOGIC® | SuperSOT™-8 | UniFET™ |
| FETBench™ | OPTOPLANAR® | SupreMOS™ | VXC™ |
| FlashWriter® |  | SyncFET™ | VisualMax™ |
| | PDP SPM™ | Sync-Lock™ | XS™ |
| | Power-SPM™ |  | |

* Trademarks of System General Corporation, used under license by Fairchild Semiconductor.

DISCLAIMER

FAIRCHILD SEMICONDUCTOR RESERVES THE RIGHT TO MAKE CHANGES WITHOUT FURTHER NOTICE TO ANY PRODUCTS HEREIN TO IMPROVE RELIABILITY, FUNCTION, OR DESIGN. FAIRCHILD DOES NOT ASSUME ANY LIABILITY ARISING OUT OF THE APPLICATION OR USE OF ANY PRODUCT OR CIRCUIT DESCRIBED HEREIN; NEITHER DOES IT CONVEY ANY LICENSE UNDER ITS PATENT RIGHTS, NOR THE RIGHTS OF OTHERS. THESE SPECIFICATIONS DO NOT EXPAND THE TERMS OF FAIRCHILD'S WORLDWIDE TERMS AND CONDITIONS, SPECIFICALLY THE WARRANTY THEREIN, WHICH COVERS THESE PRODUCTS.

LIFE SUPPORT POLICY

FAIRCHILD'S PRODUCTS ARE NOT AUTHORIZED FOR USE AS CRITICAL COMPONENTS IN LIFE SUPPORT DEVICES OR SYSTEMS WITHOUT THE EXPRESS WRITTEN APPROVAL OF FAIRCHILD SEMICONDUCTOR CORPORATION.

As used herein:

1. Life support devices or systems are devices or systems which, (a) are intended for surgical implant into the body or (b) support or sustain life, and (c) whose failure to perform when properly used in accordance with instructions for use provided in the labeling, can be reasonably expected to result in a significant injury of the user.
2. A critical component in any component of a life support, device, or system whose failure to perform can be reasonably expected to cause the failure of the life support device or system, or to affect its safety or effectiveness.

ANTI-COUNTERFEITING POLICY

Fairchild Semiconductor Corporation's Anti-Counterfeiting Policy. Fairchild's Anti-Counterfeiting Policy is also stated on our external website, www.fairchildsemi.com, under Sales Support.

Counterfeiting of semiconductor parts is a growing problem in the industry. All manufacturers of semiconductor products are experiencing counterfeiting of their parts. Customers who inadvertently purchase counterfeit parts experience many problems such as loss of brand reputation, substandard performance, failed applications, and increased cost of production and manufacturing delays. Fairchild is taking strong measures to protect ourselves and our customers from the proliferation of counterfeit parts. Fairchild strongly encourages customers to purchase Fairchild parts either directly from Fairchild or from Authorized Fairchild Distributors who are listed by country on our web page cited above. Products customers buy either from Fairchild directly or from Authorized Fairchild Distributors are genuine parts, have full traceability, meet Fairchild's quality standards for handling and storage and provide access to Fairchild's full range of up-to-date technical and product information. Fairchild and our Authorized Distributors will stand behind all warranties and will appropriately address any warranty issues that may arise. Fairchild will not provide any warranty coverage or other assistance for parts bought from Unauthorized Sources. Fairchild is committed to combat this global problem and encourage our customers to do their part in stopping this practice by buying direct or from authorized distributors.

PRODUCT STATUS DEFINITIONS

Definition of Terms

Datasheet Identification	Product Status	Definition
Advance Information	Formative / In Design	Datasheet contains the design specifications for product development. Specifications may change in any manner without notice.
Preliminary	First Production	Datasheet contains preliminary data; supplementary data will be published at a later date. Fairchild Semiconductor reserves the right to make changes at any time without notice to improve design.
No Identification Needed	Full Production	Datasheet contains final specifications. Fairchild Semiconductor reserves the right to make changes at any time without notice to improve the design.
Obsolete	Not In Production	Datasheet contains specifications on a product that is discontinued by Fairchild Semiconductor. The datasheet is for reference information only.

Rev. 142