

0.14 ± 0.05
PIN WIDTH

⊕ 0.15 Y

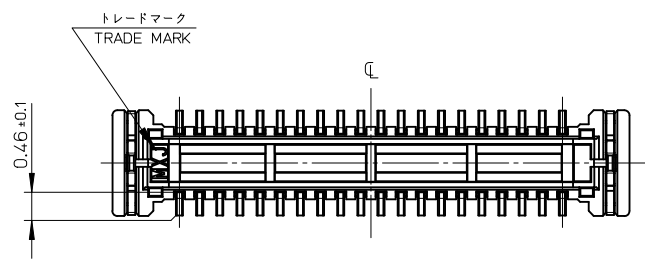
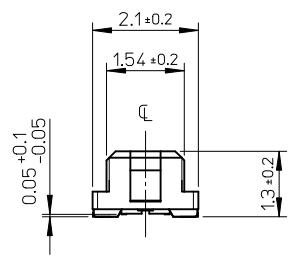
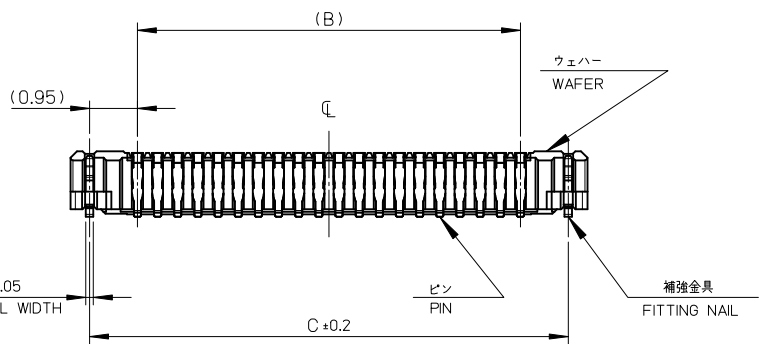

注記 NOTES

1. 使用材料 MATERIAL

ウェハ: 液晶ポリマー (LCP), ガラス充填, UL94V-0, 黒
 WAFER: LIQUID CRYSTAL POLYMER(LCP), GLASS FILLED, UL94V-0, BLACK
 ピン: りん青銅 (t=0.08)
 PIN: PHOSPHOR BRONZE (t=0.08)
 金具: りん青銅 (t=0.15)
 FITTING NAIL: PHOSPHOR BRONZE (t=0.15)

2. メッキ仕様 PLATING

ピン PIN
 金メッキ 0.1 マイクロメートル以上
 GOLD 0.1MICROMETER MINIMUM
 下地メッキ: ニッケルメッキ 1.0 マイクロメートル以上
 UNDER PLATING: NICKEL 1.0MICROMETER MINIMUM
 ※コンタクト部とテール部はニッケルメッキによって分断されている金メッキです。
 DIVIDE INTO PARTS THE GOLD PLATING OF THE CONTACT AND THE TAIL PART BY THE NICKEL PLATING.
 ※封孔処理品
 SEALING DISPOSITION

金具 FITTING NAIL

フラッシュ金メッキ
 FLASH Au PLATING
 下地メッキ: ニッケルメッキ 1.0 マイクロメートル以上
 UNDER PLATING: NICKEL 1.0MICROMETER MINIMUM

△ (全極数 / 2) = 偶数の場合に適用。
 APPLY FOR (CIRCUIT/2)=EVEN.

4. 嵌合相手: 502426 シリーズ
 MATE WITH: 502426 SERIES.

5. テール平坦度は、0.08 以下
 テール及び金具の平坦度は、0.1 以下
 TAIL COPLANARITY TO BE 0.08MAXIMUM.
 TAIL AND FITTING NAIL COPLANARITY TO BE 0.1MAXIMUM.

6. ELV 及び RoHS 適合品
 ELV AND RoHS COMPLIANT.

17.5	15.6	18.26	503460-8010	80
C	B	A	EMBOSSED TAPE	CKT.
			ORDER No. オーダー番号	
CONNECTOR SERIES No.: 503460-***19				

REVISED EC NO: J2010-2429 DRWN:TKAIHO 2010/05/31 CHKD:S.MARUYAMA 2010/06/01 APPR:MSASAO 2010/06/02	GENERAL TOLERANCES (UNLESS SPECIFIED)		DIMENSION STYLE MM ONLY	SCALE 10:1	DESIGN UNITS METRIC	THIRD ANGLE PROJECTION
	10 UNDER	± ---	DRAWN BY K. TOYODA	DATE 2009/12/02	TITLE 0.4 B-TO-B CONN. HGT=1.5 W=2.6 PLUG ASSY	
	10 OVER 30 UNDER	± ---	CHECKED BY S. MARUYAMA	DATE 2009/12/02	MOLEX INCORPORATED	
	30 OVER	± ---	APPROVED BY M. SASAO	DATE 2009/12/02	DOCUMENT NO. SD-503460-001	SHEET NO. 1 OF 2
ANGULAR	± --- °	DRAFT WHERE APPLICABLE MUST REMAIN WITHIN DIMENSIONS		SEE CHART		
SIZE A3	THIS DRAWING CONTAINS INFORMATION THAT IS PROPRIETARY TO MOLEX INCORPORATED AND SHOULD NOT BE USED WITHOUT WRITTEN PERMISSION					

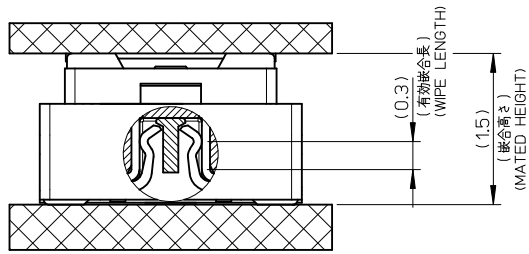

嵌合断面図 (参考)
MATED DRAWING (REFERENCE)
(SCALE 20:1)

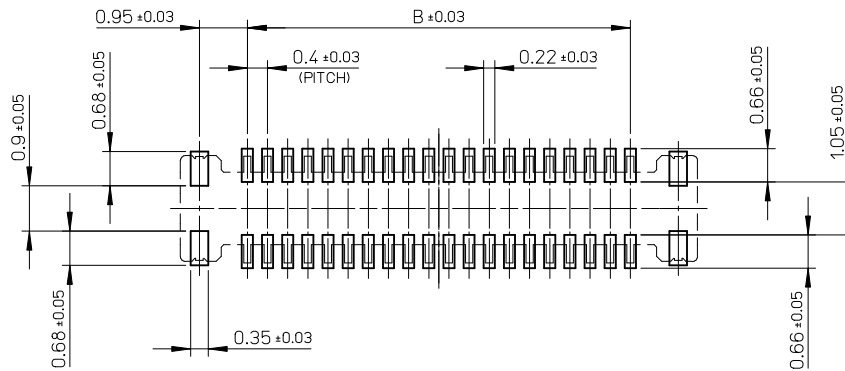

推奨基板寸法 (参考)
P.W. BOARD PATTERN LAYOUT (REFERENCE)

SEE SHEET 1 OF 2 EC NO: J2010-2429 DRWN:TKAIHO 2010/05/31 CHK'D:S. MARUYAMA 2010/06/01 APPR:MSASAO 2010/06/02	GENERAL TOLERANCES (UNLESS SPECIFIED)		DIMENSION STYLE MM ONLY	SCALE 10:1	DESIGN UNITS METRIC	THIRD ANGLE PROJECTION	
	10 UNDER	±---	DRAWN BY K. TOYODA	DATE 2009/12/02	TITLE 0.4 B-T-O-B CONN. HGT=1.5 W=2.6 PLUG ASSY		
	10 OVER 30 UNDER	±---	CHECKED BY S. MARUYAMA	DATE 2009/12/02	MOLEX INCORPORATED DOCUMENT NO. SD-503460-001 SHEET NO. 2 OF 2		
	30 OVER	±---	APPROVED BY M. SASAO	DATE 2009/12/02			
	ANGULAR	±---°	MATERIAL NO. SEE SHEET 1		THIS DRAWING CONTAINS INFORMATION THAT IS PROPRIETARY TO MOLEX INCORPORATED AND SHOULD NOT BE USED WITHOUT WRITTEN PERMISSION		
DRAFT WHERE APPLICABLE MUST REMAIN WITHIN DIMENSIONS		SIZE A3					

注記 NOTES

- 製品詳細寸法については製品単体図面を参照下さい。
FOR DETAIL OF CONNECTOR DIMENSIONS,
PLEASE SEE THE DRAWING OF CONNECTOR ITSELF (NOT PACKAGED).
- 梱包数量: 3000 個/リール
NUMBER OF CONNECTORS : 3000PCS/REEL
- リードテープ長さ LEAD TAPE LENGTH

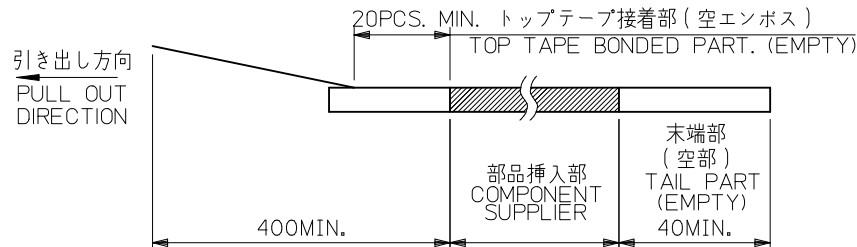

- 材料 MATERIAL
キャリアテープ (CARRIER TAPE) : ポリスチレン (POLYSTYRENE)
トップテープ (TOP TAPE) : PET, OTHER
リール (REEL) : ポリスチレン (PS) <リサイクル材を含む>
POLYSTYRENE (PS) <RECYCLE MATERIAL CONTAINED>
- ELV 及び RoHS 適合品
ELV AND RoHS COMPLIANT

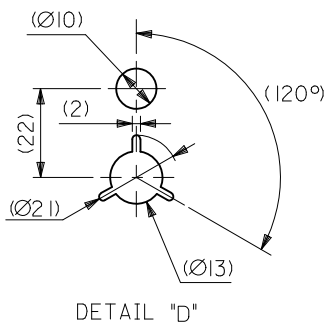
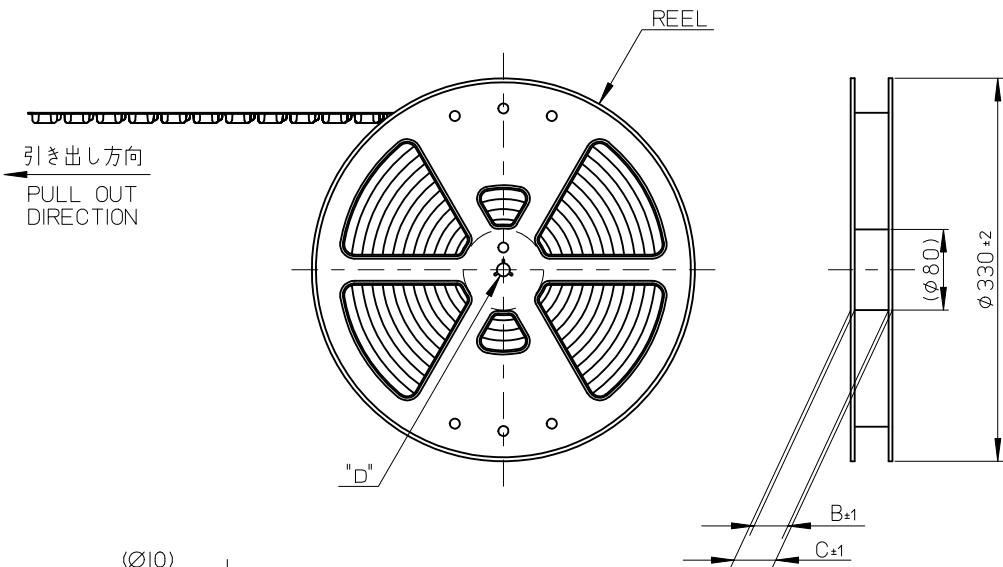

MODEL NO. : 503460-**10

RELEASED EC NO: J2010-1155 DRW:K.TOYODA 2009/12/08 CHK:D.SMARUYAMA 2009/12/08 APPR:M.SASAO 2009/12/08	GENERAL TOLERANCES (UNLESS SPECIFIED)		DIMENSION STYLE MM ONLY		SCALE ---	DESIGN UNITS METRIC	THIRD ANGLE PROJECTION	
	10 UNDER	±---	DRAWN BY K. TOYODA	DATE 2009/12/02	TITLE 0.4 B-T0-B CONN. HGT=1.5 W=2.6 PLUG ASSY EMBSTP PKG			
	10 OVER 30 UNDER	±---	CHECKED BY S. MARUYAMA	DATE 2009/12/02	MOLEX INCORPORATED			
	30 OVER	±---	APPROVED BY M. SASAO	DATE 2009/12/02	DOCUMENT NO. SD-503460-002			
	ANGULAR	±---°	MATERIAL NO. SEE CHART		SHEET NO. 1 OF 2			
DRAFT WHERE APPLICABLE MUST REMAIN WITHIN DIMENSIONS		THIS DRAWING CONTAINS INFORMATION THAT IS PROPRIETARY TO MOLEX INCORPORATED AND SHOULD NOT BE USED WITHOUT WRITTEN PERMISSION						

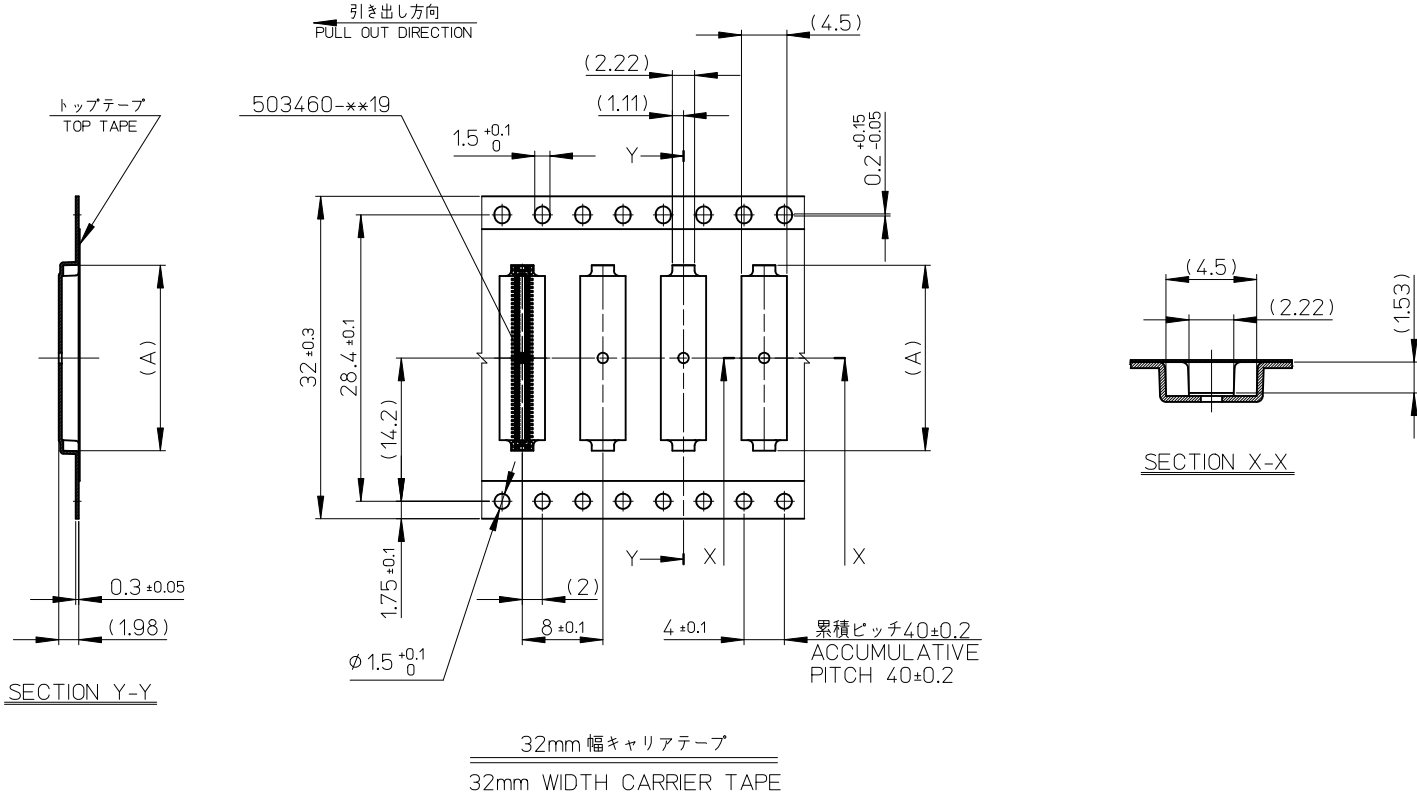

32mm 幅キャリアテープ
32mm WIDTH CARRIER TAPE

32	37.4	33.4	18.38	503460-8010	80
キャリアテープ幅 CARRIER TAPE WIDTH			C	B	(A)
				MATERIAL No.	CKT.
				MODEL No. : 503460-**-10	

SEE SHEET 1 OF 2 EC NO.: J2010-1155 DRWNG: K.TOYODA 2009/12/08 CHK'D: S.MARUYAMA 2009/12/08 APPR: M.SASAO 2009/12/08	GENERAL TOLERANCES (UNLESS SPECIFIED)	DIMENSION STYLE	SCALE	DESIGN UNITS	THIRD ANGLE PROJECTION
	10 UNDER ±---	MM ONLY	2:1	METRIC	☉ □
	10 OVER 30 UNDER ±---	DRAWN BY DATE	TITLE		
	30 OVER ±---	K.TOYODA 2009/12/02	0.4 B-TO-B CONN. HGT=1.5 W=2.6 PLUG ASSY EMBSTP PKG		
	ANGULAR ±---°	CHECKED BY DATE	MOLEX INCORPORATED		
DRAFT WHERE APPLICABLE MUST REMAIN WITHIN DIMENSIONS	S.MARUYAMA 2009/12/02	APPROVED BY DATE	MATERIAL NO.	DOCUMENT NO.	SHEET NO.
	M.SASAO 2009/12/02	SEE CHART	SD-503460-002		2 OF 2
		SIZE A3	THIS DRAWING CONTAINS INFORMATION THAT IS PROPRIETARY TO MOLEX INCORPORATED AND SHOULD NOT BE USED WITHOUT WRITTEN PERMISSION		