

LOC		DIST		REVISIONS			
P	LTR	DESCRIPTION	DATE	DNW	APVD		
Y		REV PER ECO-15-016062	09NOV15	KG	CD		

- 204509-1 IS DESIGNED TO CONFORM TO THE LATEST ISSUE OF MIL-C-24308.
 - MAX WIRE INSUL. TO BE USED WITH THIS PLUG IS .054 DIA.
 - METAL RETENTION CLIPS ARE INCLUDED IN INSERTS.
 - PACKAGE STAMPED M 24308/4-268F, 204509-1 ONLY.
 - THIS PLUG WILL ACCEPT SIZE 22 PIN CONTACT M 39029/58-360 OR ANY TYCO HDD-22 PIN CONTACT.
- ⑩ UL/CSA DESIGNATION STAMPED IN THIS AREA.
 - ⑧ CADMIUM PER QQ-P-416.
 - ⑨ BRIGHT TIN PER ASTM-B-545 OVER COPPER PER AMS2418.
 - ⑩ GROUNDING INDENTS ON FRONT SHELL NOT SHOWN ON DRAWING.
 - ⑪ BRIGHT TIN PER ASTM-B-545 .000400-.000550 THK OVER COPPER PER AMS2418 .000050 MIN THK.

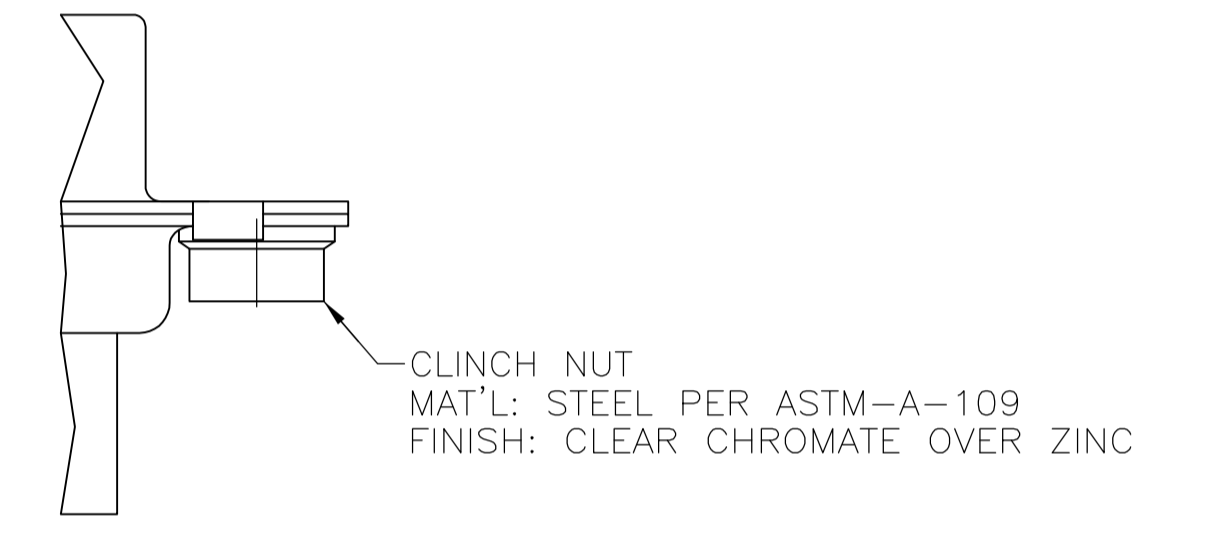

CLINCH NUT DETAIL
FOR 204509-6 ONLY
2 PLC

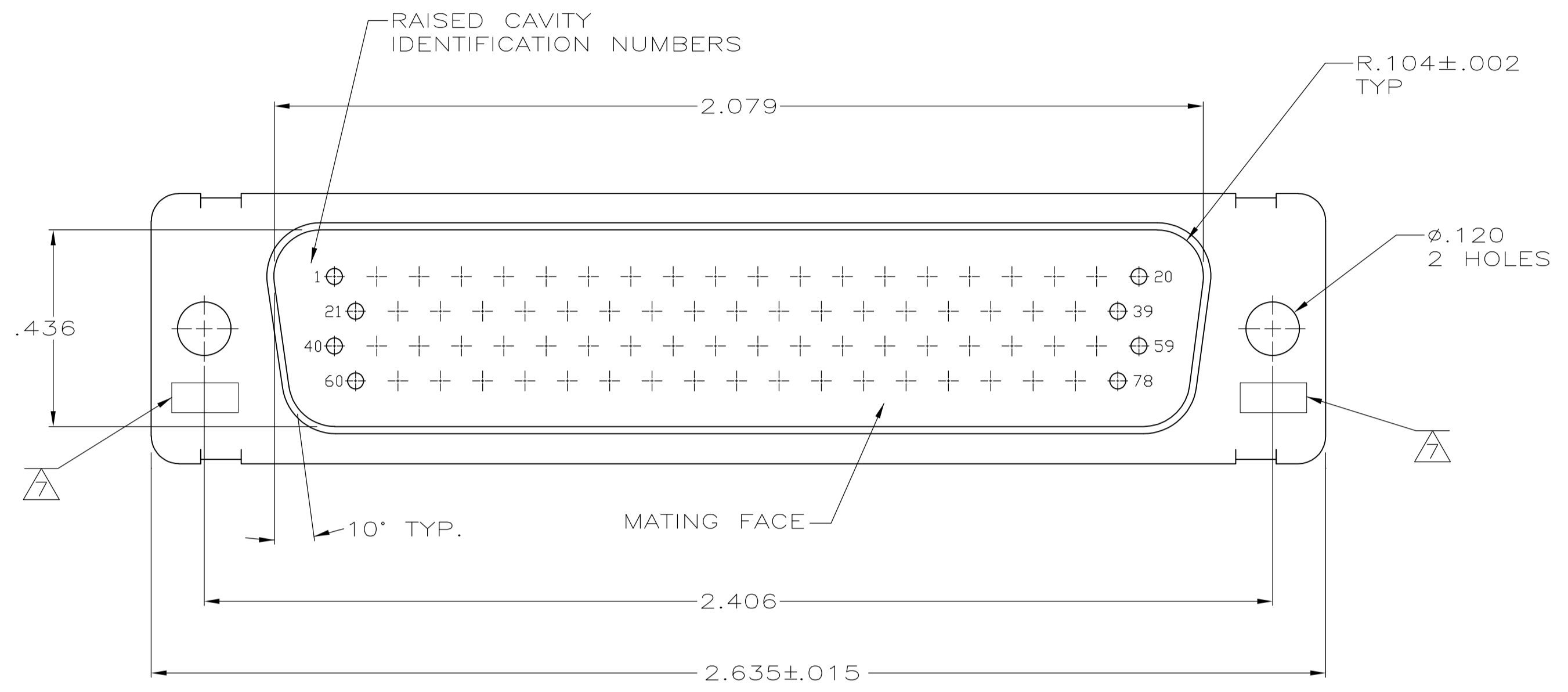
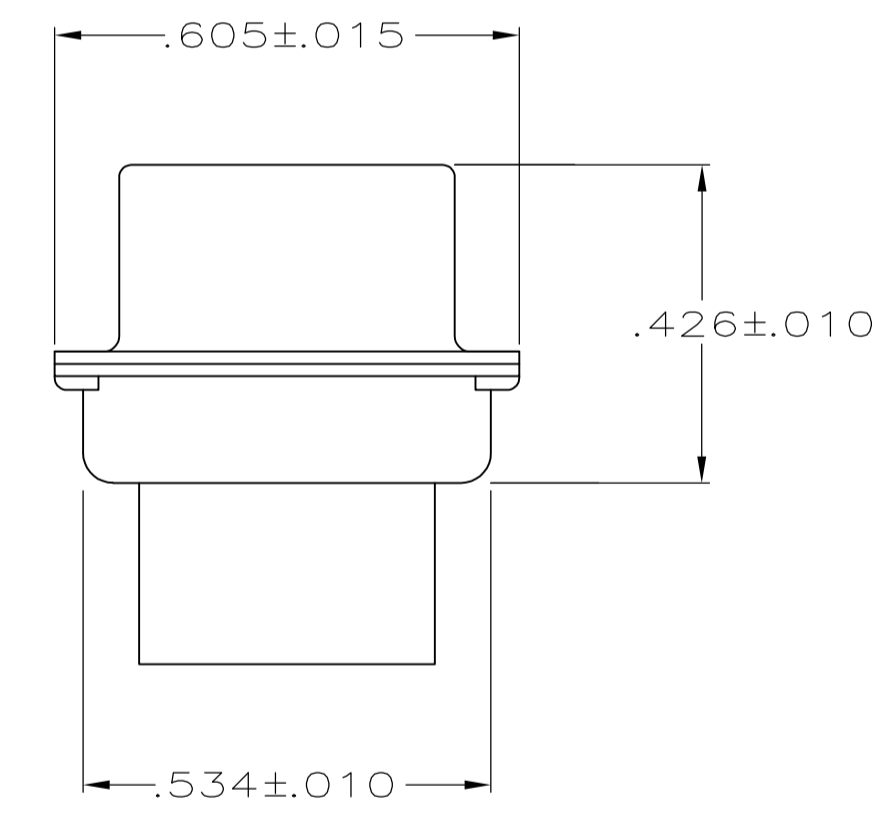
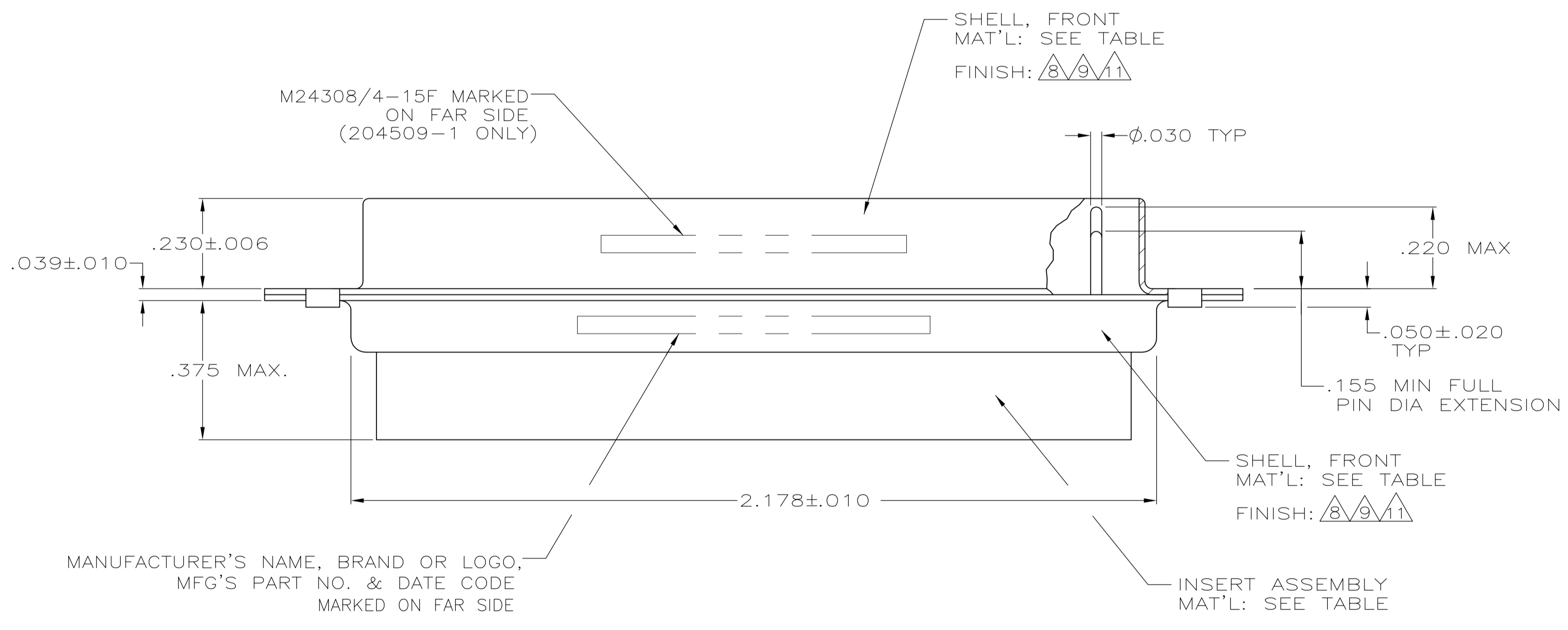

REMARKS	FINISH	INK STAMP	P/N	SHELL MATERIAL	INSERT MATERIAL	PART NO.
	⑩			STEEL PER ASTM-A-109	GST-40F PER MIL-M-24519 COLOR: BLACK	204509-8
	-			STEEL PER ASTM-A-109	GST-40F PER MIL-M-24519 COLOR: BLACK	204509-7
	SEE CLINCH NUT DETAIL			STEEL PER ASTM-A-109	GST-40F PER MIL-M-24519 COLOR: BLACK	204509-6
	⑩			STEEL PER ASTM-A-109	GST-40F PER MIL-M-24519 COLOR: BLACK	204509-5
SUPSD BY 204509-1	-			STEEL PER ASTM-A-109	GST-40F PER MIL-M-24519 COLOR: BLACK	204509-3
SUPSD BY 206504-4	-			BRASS	GST-40F PER MIL-M-24519 COLOR: BLACK	204509-2
	⑧			STEEL PER ASTM-A-109	GST-40F PER MIL-M-24519 COLOR: BLACK	204509-1

THIS DRAWING IS A CONTROLLED DOCUMENT. **STE** TE Connectivity

APVD: LARRY OH 13-NOV-99
CHK: C.C.THOMAS 13-NOV-99

NAME: PLUG ASSY, AMPLIMITE, 78 POSN SIZE 5, SERIES 90

PRODUCT SPEC: -
APPLICATION SPEC: -

SIZE: A1
CAGE CODE: 00779
DRAWING NO: 204509

RESTRICTED TO: -
WEIGHT: -
CUSTOMER DRAWING: -
SCALE: 4:1
SHEET: 1 OF 1
REV: Y