



## Part Number: D3C4043

### Electrical Specifications

Frequency Range (GHz):	40.0 – 43.5
Isolation (dB):	18 MIN
Insertion Loss (dB):	1.2 MAX
VSWR:	1.5:1 MIN
Forward Power (W):	5 AVG 30 PK

### Mechanical/Environmental Specifications

Connector Type:	K (2.92mm)
Connector Body:	Passivated stainless steel
Connector Pin:	Gold plated copper
Load Body:	Brass
Magnetic Shunt:	Nickel plated CRS
Operational Temp:	-20°C to +65°C
Weight (oz)	0.9 MAX

### D3C4043 Dimensions

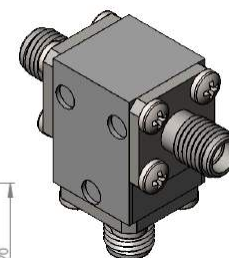
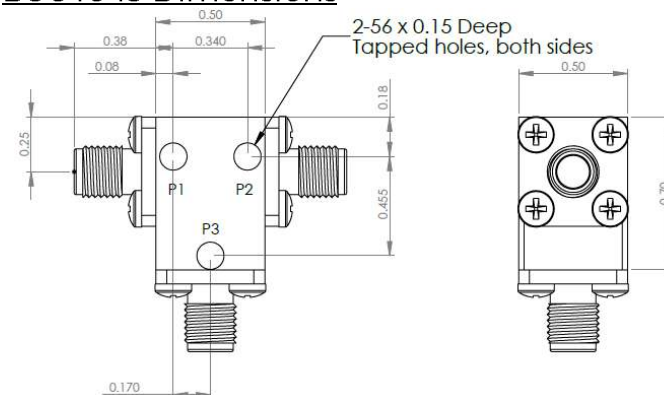

### D3C4043-3 Dimensions

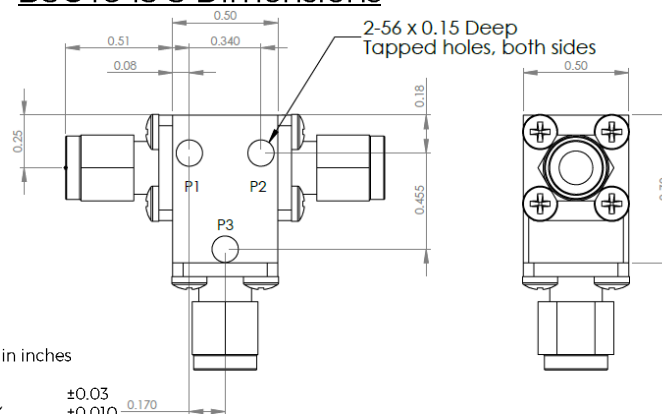

Type of Device	PN Suffix	Connector Configuration Input / Output	PN Example
Single Junction Circulator 3-Port Device Port 1 / Port 2 / Port 3	No Dash	Female / Female / Female	D3C4043
	-1	Male / Female / Female	D3C4043-1
	-2	Female / Male / Female	D3C4043-2
	-3	Male / Male / Male	D3C4043-3
	-4	Female / Female / Male	D3C4043-4
	-5	Male / Female / Male	D3C4043-5
	-6	Male / Male / Female	D3C4043-6
	-7	Female / Male / Male	D3C4043-7



## MEASURED DATA

Part Number: D3C4043, P1→P2, P3 Terminated with 50Ω, +25°C

