

TOP VIEW

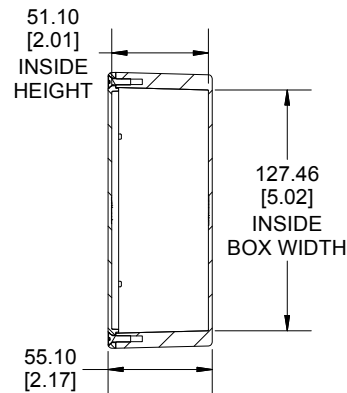

SECTION A-A  
END VIEW

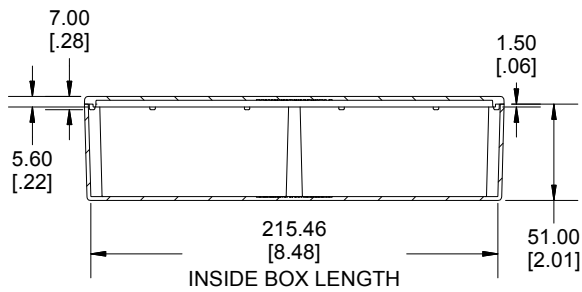
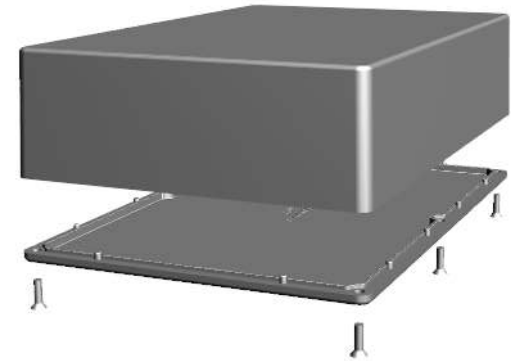

SECTION B-B  
SIDE VIEW

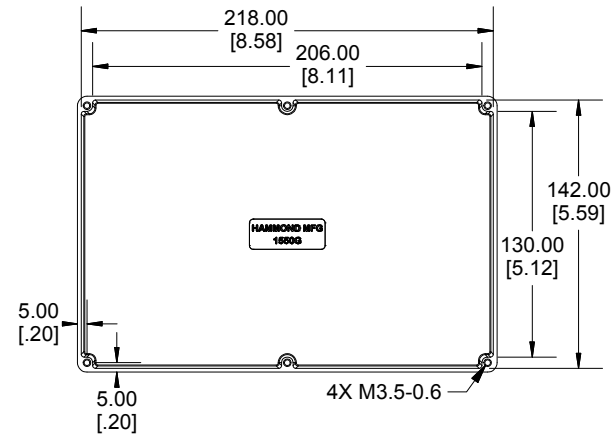
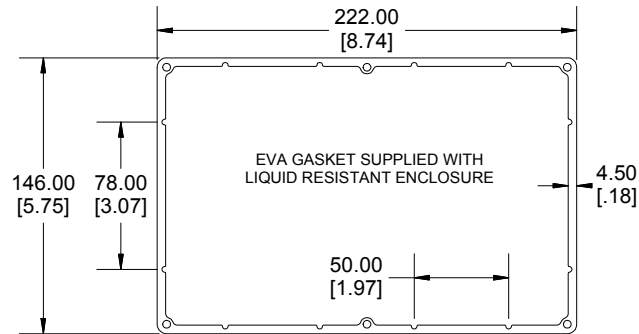

INSIDE BOX

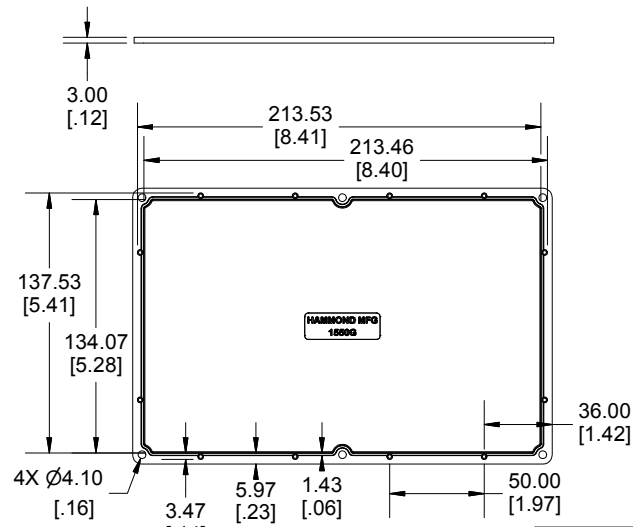

INSIDE LID

Dimensions:  
mm  
[inches]

Enclosures can be Factory Modified ( Milling, Drilling, Printing etc.)  
Contact Factory [mjm@hammondmfg.com](mailto:mjm@hammondmfg.com) for quotes  
Solid models of this enclosure available in STEP or IGES.

NOTE	
Purchased assembly includes box, lid and 6 cover screws.	
Box and lid are made from Diecast Aluminum Alloy.	
EVA Gasket supplied with liquid resistant enclosure.	

PART NUMBERS	
1550G Enclosure	
Natural Finish Enclosure	1550G
Black Textured Enclosure	1550GBK
1550G Liquid Resistant Enclosure (EVA Gasket)	
Natural Finish Enclosure	1550WG
Black Textured Enclosure	1550WGBK
ACCESSORIES	
Recommended Torque: 75 ozf.in / 55 cN.m	
Standard Cover Screws	
Plated Cover Screws (Pkg 100) [M3.5-0.6 x 12mm]	1550MS100
Black Cover Screws (Pkg 100) [M3.5-0.6 x 12mm]	1550MS100BK
Liquid Resistant Cover Screws and Gaskets	
Stainless Steel Cover Screws (Pkg 100) [M3.5 x 12mm, With O-Ring]	1550WMS100
Black Stainless Steel Cover Screws (Pkg 100) [M3.5 x 12mm, With O-Ring]	1550WMS100BK
EVA Pre-formed Gasket Black	1550GEGASKET
Silicone Pre-formed Gasket Black	1550GSGASKET

