

THIS DRAWING IS UNPUBLISHED. RELEASED FOR PUBLICATION 20
 © COPYRIGHT 20 BY - ALL RIGHTS RESERVED.

REVISIONS					
P	LTR	DESCRIPTION	DATE	DWN	APVD
B		LC20-0020-09 / ECO-09-011930	23FEB2009	DM	BJ
C		LC20-0094-09 / ECO-09-018257	04AUG2009	DM	BJ
D		LC20-0144-14 / ECO-14-016321	24NOV2014	DM	BJ
E		LC20-0069-20 / ECO-20-009580	06JUL2020	DM	BJ

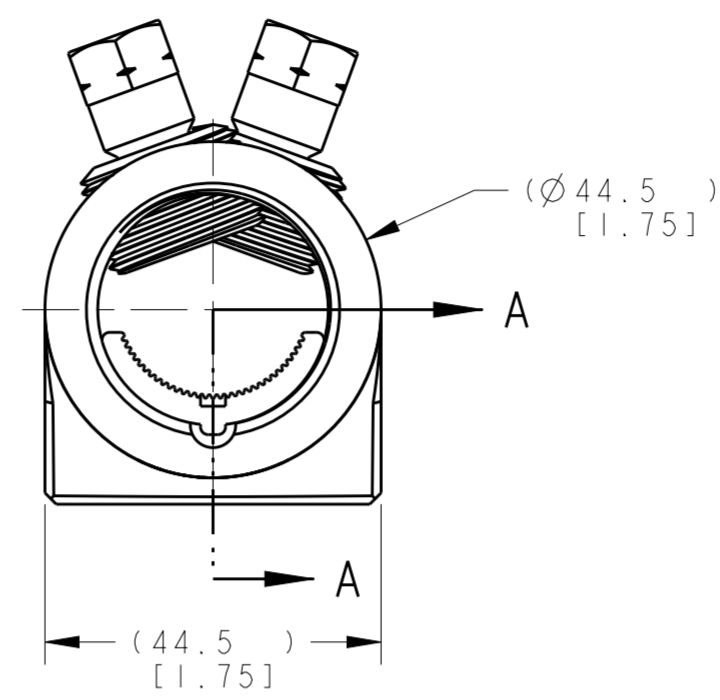

- ACCOMMODATES:
600 KCMIL COMPACT STR (Ø20.7 [.813 DIA])
TO 1000 KCMIL STD STR (Ø29.3 [1.152 DIA])
ALUMINUM OR COPPER CONDUCTORS.
- MARKING:
STE
ASBT-600-1000
MADE IN [COUNTRY OF ORIGIN]
[DATE CODE]
- ALL DIMENSIONS ARE FOR REFERENCE ONLY.
- INSERT SHALL BE REMOVED FOR CONDUCTOR SIZES GREATER THAN 750 KCMIL STD STR Ø25.4 [1.998 DIA]
- CONNECTOR CONTAINS FACTORY APPLIED ANTI-OXIDE INHIBITOR.
- FINISH:
ELECTRO-TIN PLATED.
- INSTALL BOLTS WITH 13 mm [1/2 inch] HEX SOCKET.

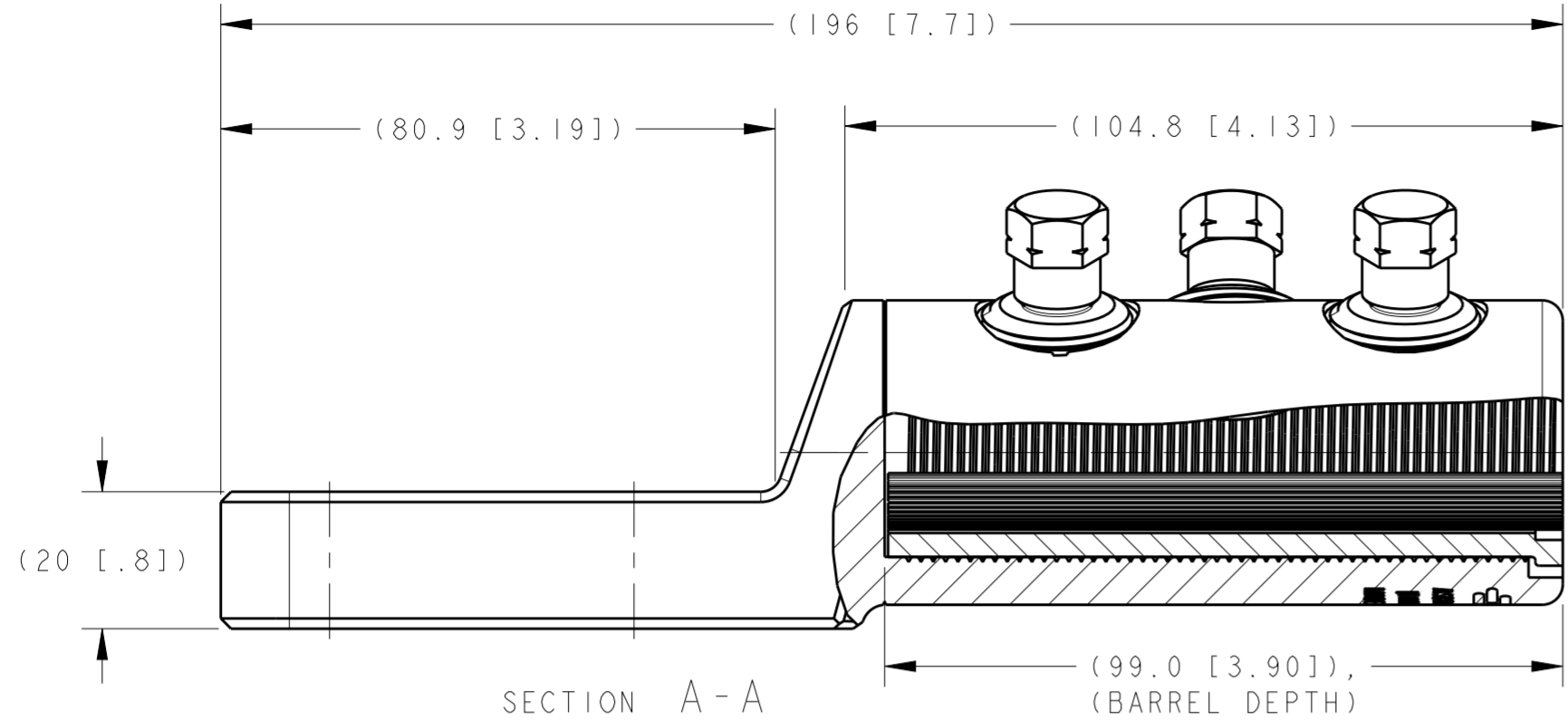
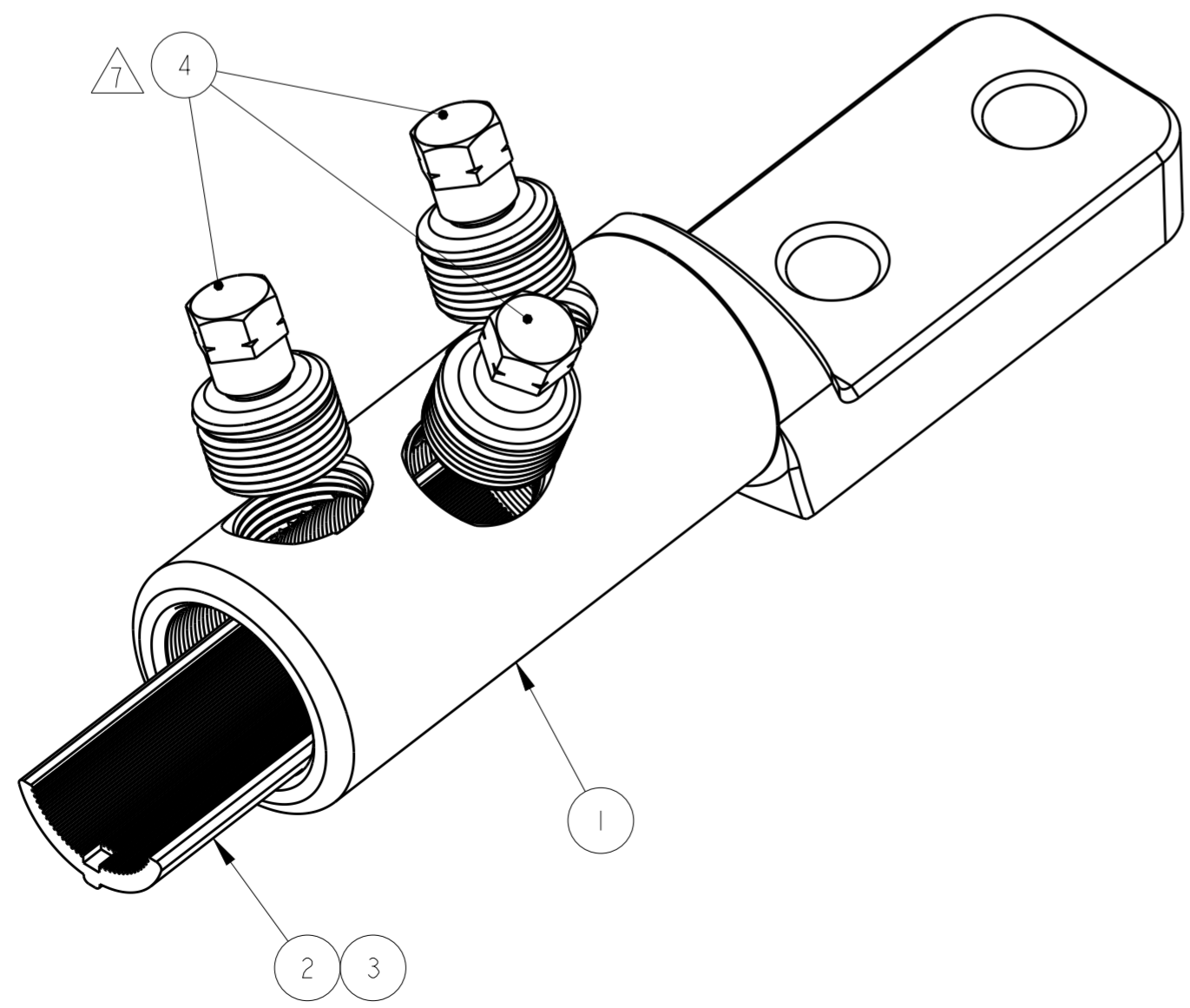
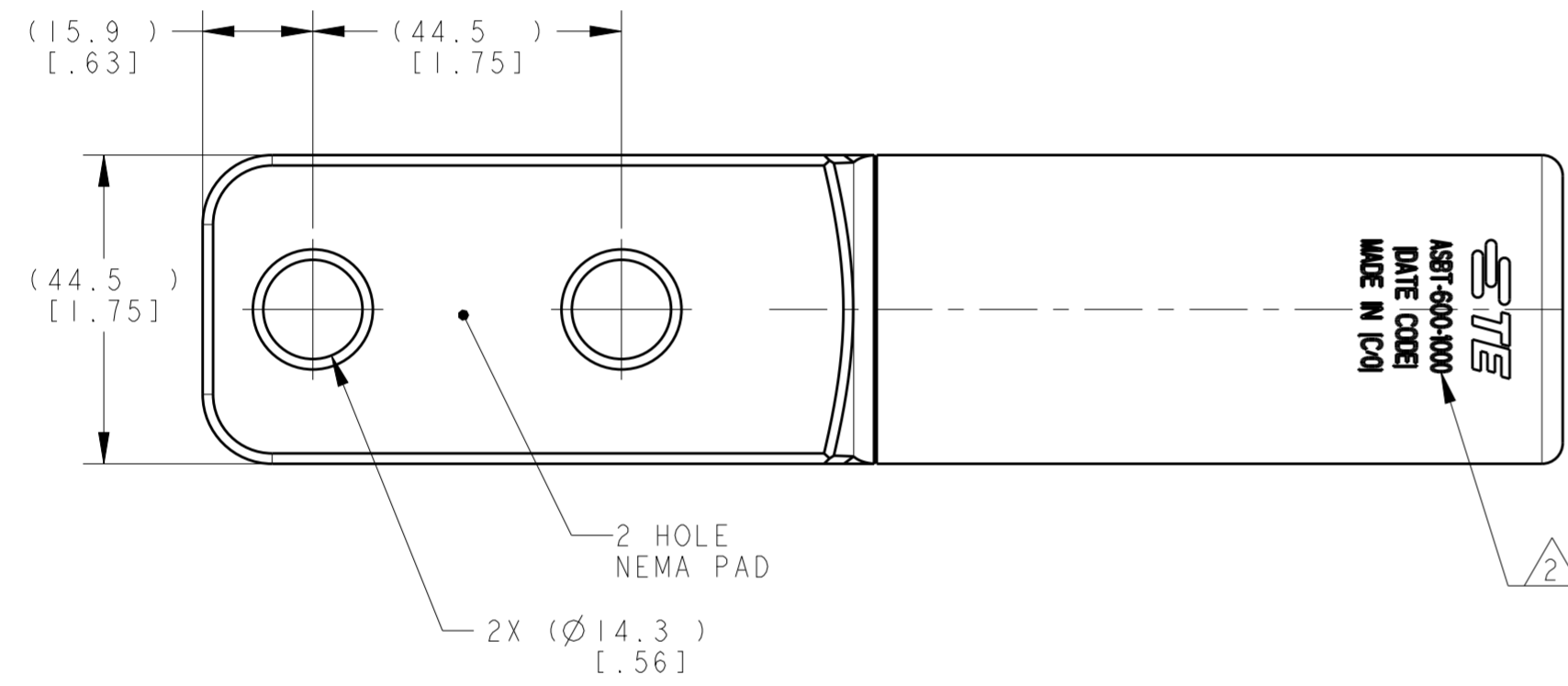

ASBT-600-1000	1099585-1
CATALOG NO	PART NO

QTY	DESCRIPTION	ITEM NO
1	INSTALLATION INSTRUCTION SHEET, 408-10264	6
1	ABRASIVE TAPE	5
3	MULTI-SHEAR BOLT, M22 SIZE, ALUMINUM	4
A/R	INHIBITOR	3
1	INSERT, ALUMINUM, 600 - 1000 KCMIL	2
1	TERMINAL CONNECTOR BODY, ALUMINUM, 600 - 1000 KCMIL	1

THIS DRAWING IS A CONTROLLED DOCUMENT.

DWN: D. MURUGLAH 05 JUN 2008	TE Connectivity				
CHK: A. BULZA 05 JUN 2008					
APVD: B. JOHNSON 05 JUN 2008					
NAME: SHEARBOLT TERMINAL, ALUMINUM, 2 HOLE NEMA PAD, 600-1000 KCMIL					
DIMENSIONS: mm [INCHES]	TOLERANCES UNLESS OTHERWISE SPECIFIED:	SIZE: A2	CAGE CODE: 00779	DRAWING NO: C-1099585	RESTRICTED TO: -
0 PLC ±	1 PLC ±	2 PLC ±	3 PLC ±	4 PLC ±	ANGLES ±
MATERIAL: SEE BOM	FINISH: SEE BOM	WEIGHT: -	SCALE: 1:1	SHEET: 1 OF 1	REV: E

Customer Drawing