

Product Document



Application Note

POS Sensors

Tape & Reel Packing Information

Content Guide

1	General Description	3
2	Tape & Reel	4
3	Carrier Tape	5
3.1	SSOP-16	5
3.2	TSSOP-14 (TSSOP-16)	6
3.3	TSSOP-20	6
3.4	SOIC-8	7
3.5	WL-CSP (1.425 x 1.065)	7
3.6	MLF-16 6x6 / MLF-40 7x7	8
3.7	MLF-32 7x7	8
3.8	QFN-16 4x4	9
3.9	QFN-32 7x7	9
3.10	SIP	10
4	Reel Types	11
4.1	7"	11
4.2	13"	12
5	Dry-pack	13
5.1	Moisture Sensitivity	13
5.2	Dry packaging	13
6	Contact Information	14
7	Copyrights & Disclaimer	15
8	Revision Information	16

1 General Description

This application note describes ams tape & reel packaging information of magnetic position sensors.

Table 1: Package Overview (only T&R)

Package	Device	Device per reel	
		7"	13"
SSOP16	AS5040	500	2000
	AS5045B		
	AS5140H		
	AS5145H		
	AS5145A AS5145B		
	AS5115		
	AS5045	-	2000
TSSOP-14	AS5048A AS5048B	500	4500
	AS5047P AS5047D		
	AS5147P AS5147		
	AS5403		
	AS5410		
TSSOP-20	AS5304 AS5306	500	4500
	AS5311		
	NSE-5310		
SOIC-8	AS5600 AS5601	500	2500
	AS5510		
	AS5161 AS5162		
	AS5170A AS5170B		
WL-CSP	AS5510	1000	12000
MLF-16	AS5262 AS5261	500	4000
MLF-32	AS5215	500	4000
MLF-40 7x7	AS5247	1000	4000
QFN-16	AS5055A AS5050A	500	6000
QFN-32	AS5245	500	4000
SIP	AS5171A AS5171B	-	3000

2 Tape & Reel

The tape-and-reel configuration is used for transport and storage from the manufacturer (ams AG) to the customer, and for use in the customer manufacturing plant. The configuration is designed for feeding components to automatic-placement machines for surface mounting on board assemblies. The complete configuration consists of a carrier tape with sequential individual cavities that hold individual components, and a cover tape that seals the carrier tape to retain the components in the cavities.

Single reels are packed into dry-pack and inserted into intermediate boxes before shipping.

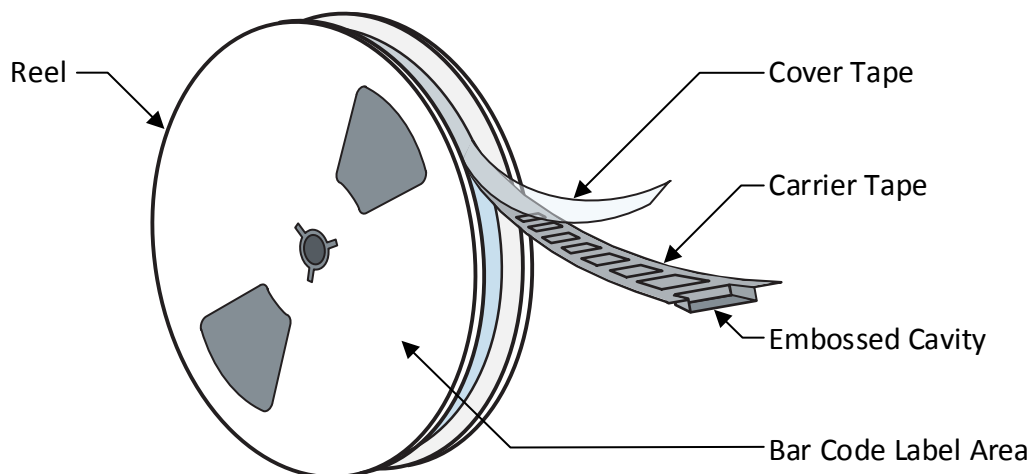

Figure 1: Reel

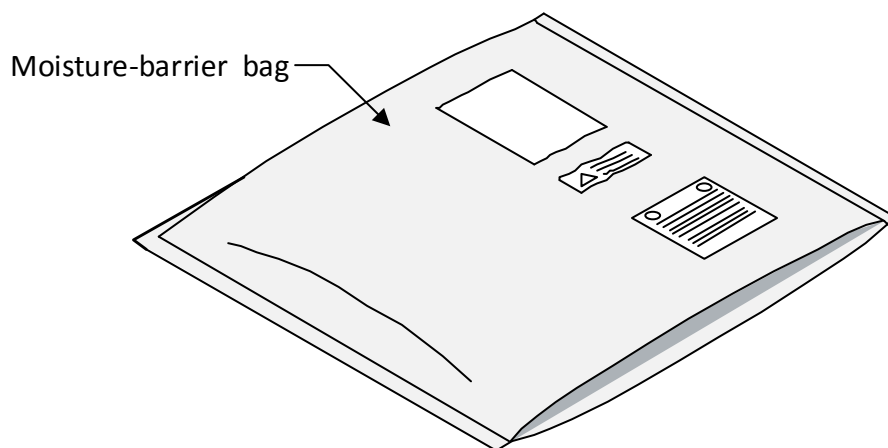

Figure 2: Single reel in dry-pack

3 Carrier Tape

Carrier tape is widely used for presenting devices to pick-and-place machines for automatic placement onto printed circuit boards.

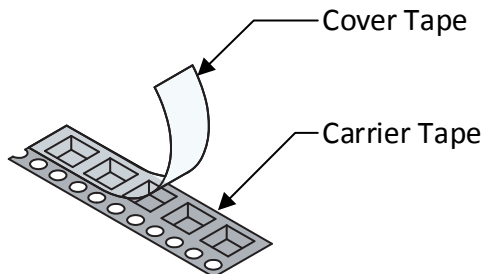
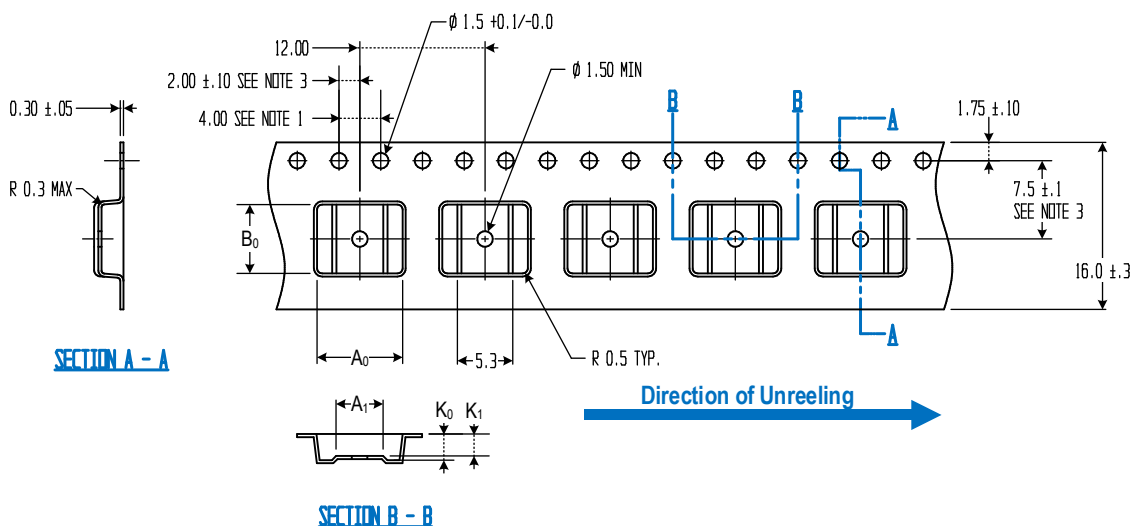

Figure 3: Carrier tape

Figure 8 shows the basic outline and dimension labels of the carrier tape. Typically, the carrier tape is constructed from a polystyrene (PS) or PS-laminate film.

3.1 SSOP-16



A0	8.20
A1	4.50
B0	6.60
K0	2.50
K1	2.10

Note1: sprocket hole pitch cumulative tolerance ± 0.2

Note2: Camber in Compliance with EIA 481

Note3: pocket position relative to sprocket hole measured as true position of pocket, not pocket hole

Note4: all dimensions in mm

3.2 TSSOP-14 (TSSOP-16)

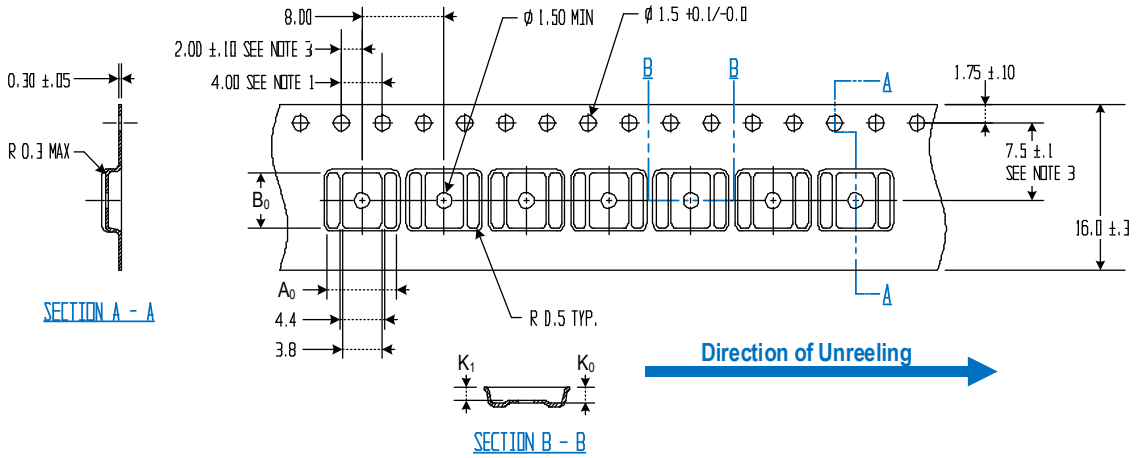

A₀ 6.80

B₀ 5.40

K₀ 1.60

K₁ 1.30

Note1: sprocket hole pitch cumulative tolerance ±0.2

Note2: Camber in Compliance with EIA 481

Note3: pocket position relative to sprocket hole measured as true position of pocket, not pocket hole

Note4: all dimensions in mm

3.3 TSSOP-20

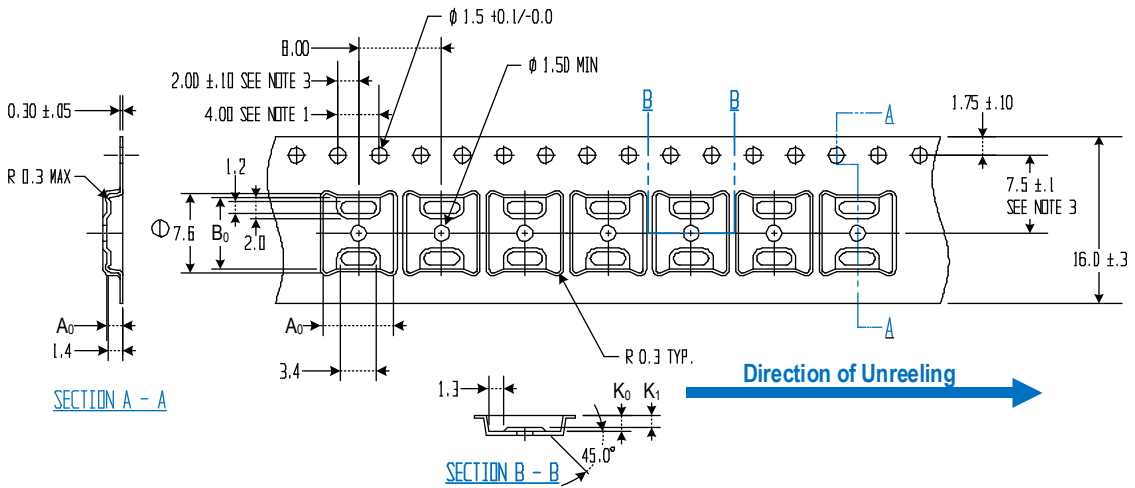

A₀ 6.80

B₀ 6.90

K₀ 1.60

K₁ 1.20

Note1: sprocket hole pitch cumulative tolerance ±0.2

Note2: Camber in Compliance with EIA 481

Note3: pocket position relative to sprocket hole measured as true position of pocket, not pocket hole

Note4: all dimensions in mm

3.4 SOIC-8

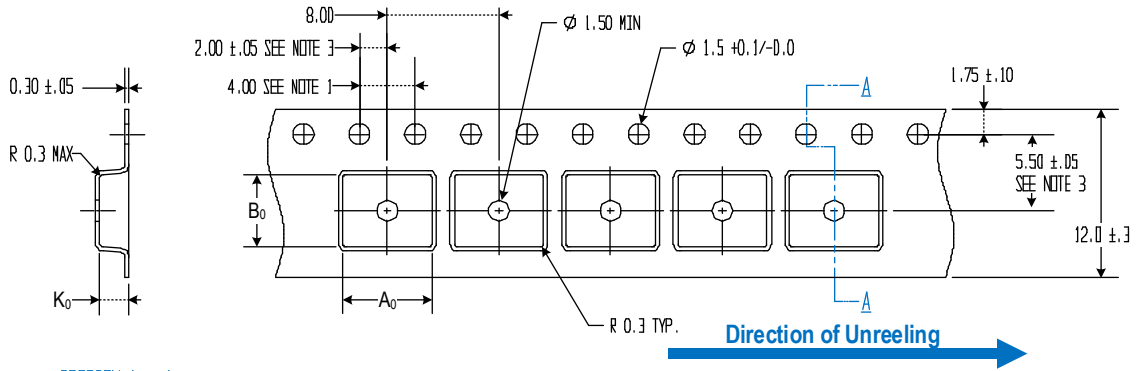

SECTION A - A

A0	6.40
B0	5.20
K0	2.10

Note1: sprocket hole pitch cumulative tolerance ± 0.2

Note2: Camber in Compliance with EIA 481

Note3: pocket position relative to sprocket hole measured as true position of pocket, not pocket hole

Note4: all dimensions in mm

3.5 WL-CSP (1.425 x 1.065)

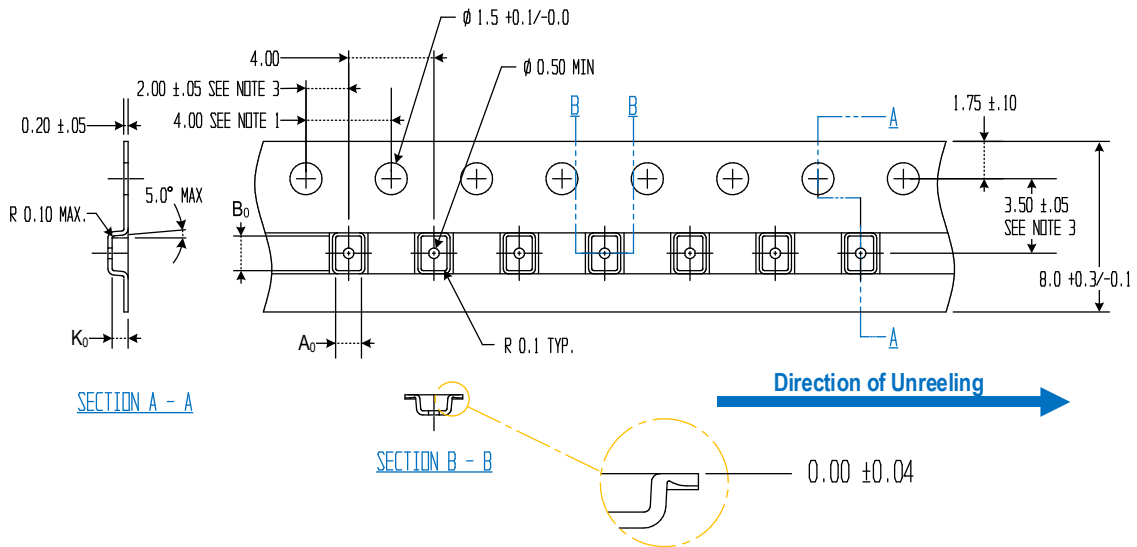

SECTION A - A

SECTION B - B

A0	1.21 ±0.05
B0	1.62 ±0.05
K0	0.75 ±0.05

Note1: sprocket hole pitch cumulative tolerance ± 0.2

Note2: Camber in Compliance with EIA 481

Note3: pocket position relative to sprocket hole measured as true position of pocket, not pocket hole

Note4: A0 and B0 are calculated on a plane at a distance "R" above the bottom of the pocket.

Note5: all dimensions in mm

3.6 MLF-16 6x6 / MLF-40 7x7

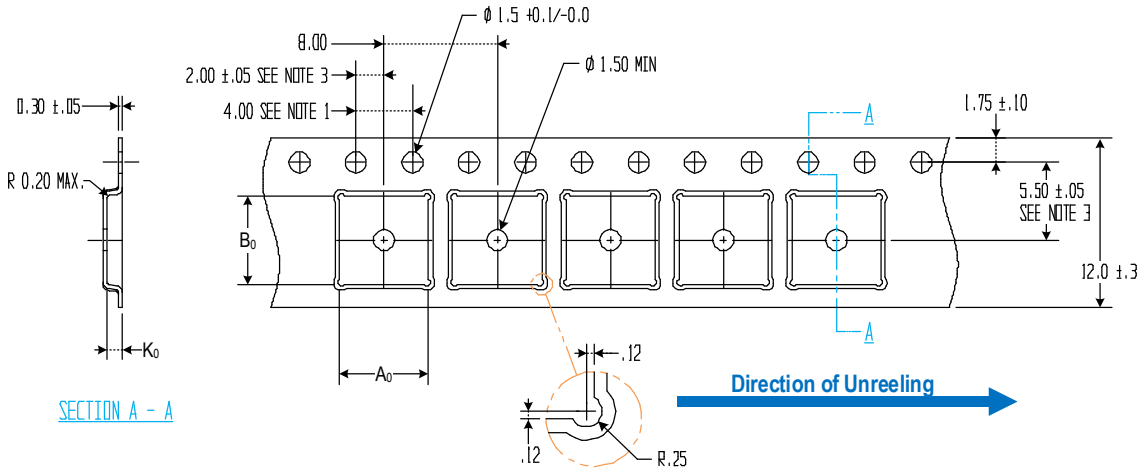

SECTION A - A

A0	6.30
B0	6.30
K0	1.10

Note1: sprocket hole pitch cumulative tolerance ± 0.2

Note2: Camber in Compliance with EIA 481

Note3: pocket position relative to sprocket hole measured as true position of pocket, not pocket hole

Note4: all dimensions in mm

3.7 MLF-32 7x7

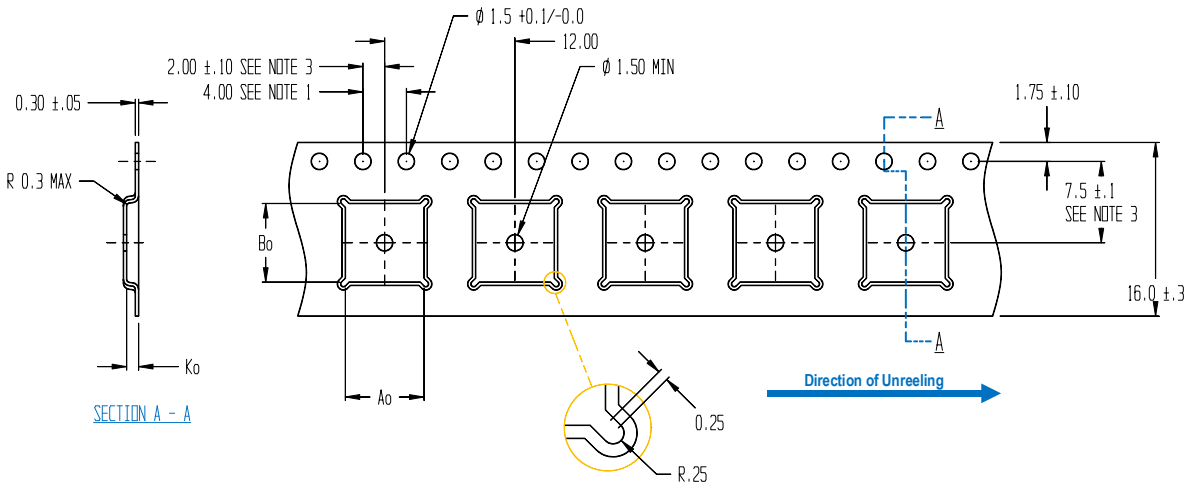

SECTION A - A

A0	7.25
B0	7.25
K0	1.10

Note1: sprocket hole pitch cumulative tolerance ± 0.2

Note2: Camber in Compliance with EIA 481

Note3: pocket position relative to sprocket hole measured as true position of pocket, not pocket hole

Note4: all dimensions in mm

3.8 QFN-16 4x4

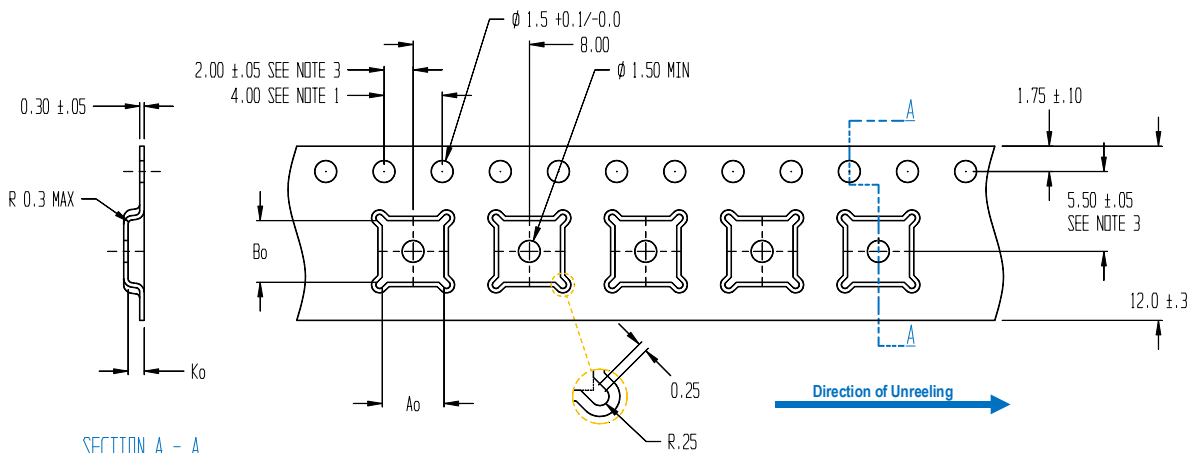

SECTION A - A

A0	4.25
B0	4.25
K0	1.10

Note1: sprocket hole pitch cumulative tolerance ± 0.2

Note2: Camber in Compliance with EIA 481

Note3: pocket position relative to sprocket hole measured as true position of pocket, not pocket hole

Note4: all dimensions in mm

3.9 QFN-32 7x7

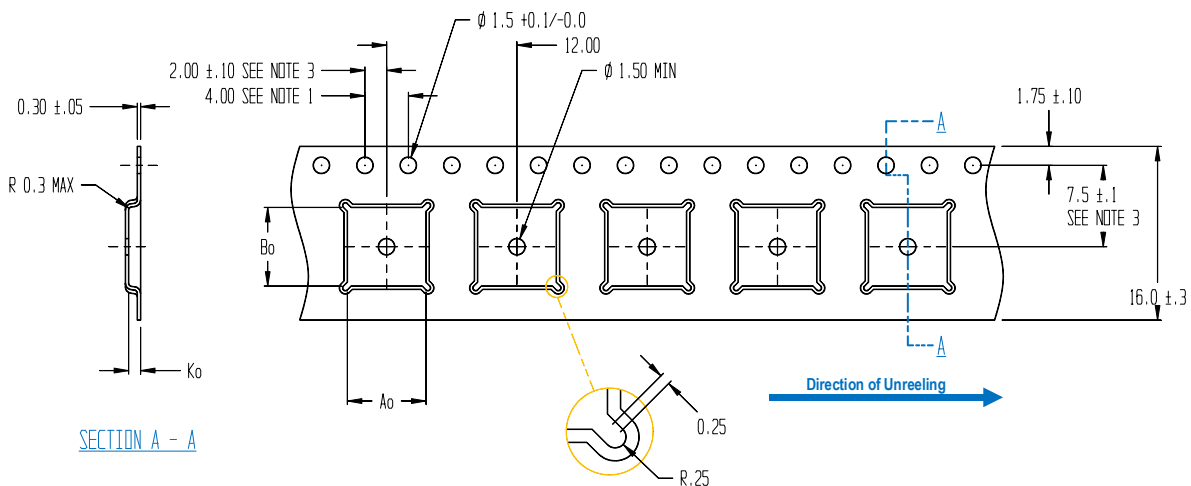

SECTION A - A

A0	7.25
B0	7.25
K0	1.10

Note1: sprocket hole pitch cumulative tolerance ± 0.2

Note2: Camber in Compliance with EIA 481

Note3: pocket position relative to sprocket hole measured as true position of pocket, not pocket hole

Note4: all dimensions in mm

3.10 SIP

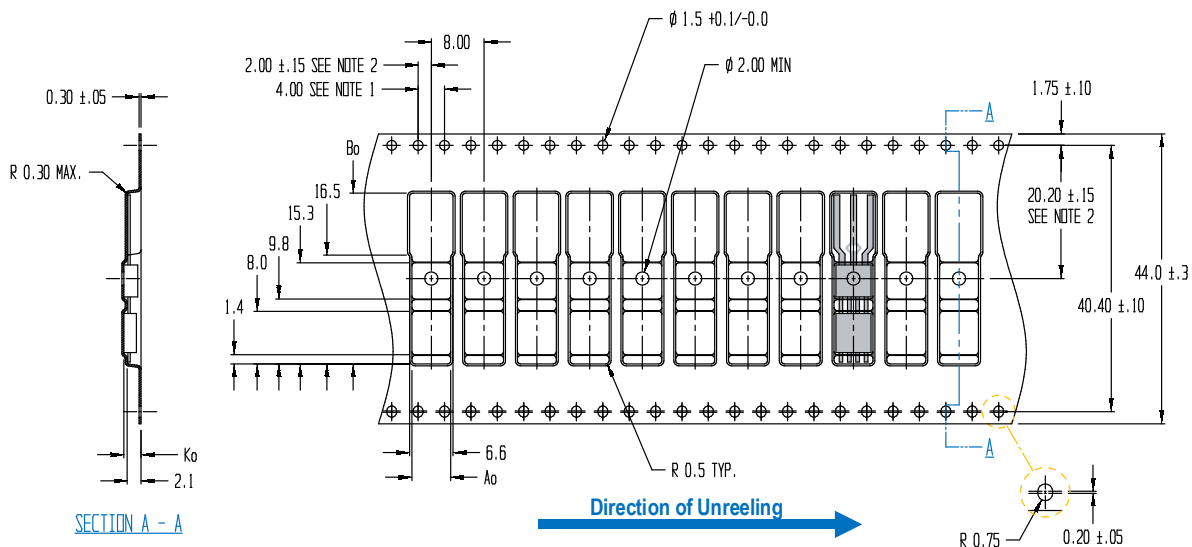

A0	5.9
B0	25.9
K0	2.6

Note1: sprocket hole pitch cumulative tolerance ± 0.2

Note2: pocket position relative to sprocket hole measured as true position of pocket, not pocket hole

Note3: A0 and B0 are calculated on a plane at a distance "R" above the bottom of the pocket.

Note4: all dimensions in mm

4 Reel Types

4.1 7"



Figure 4: reel 7"

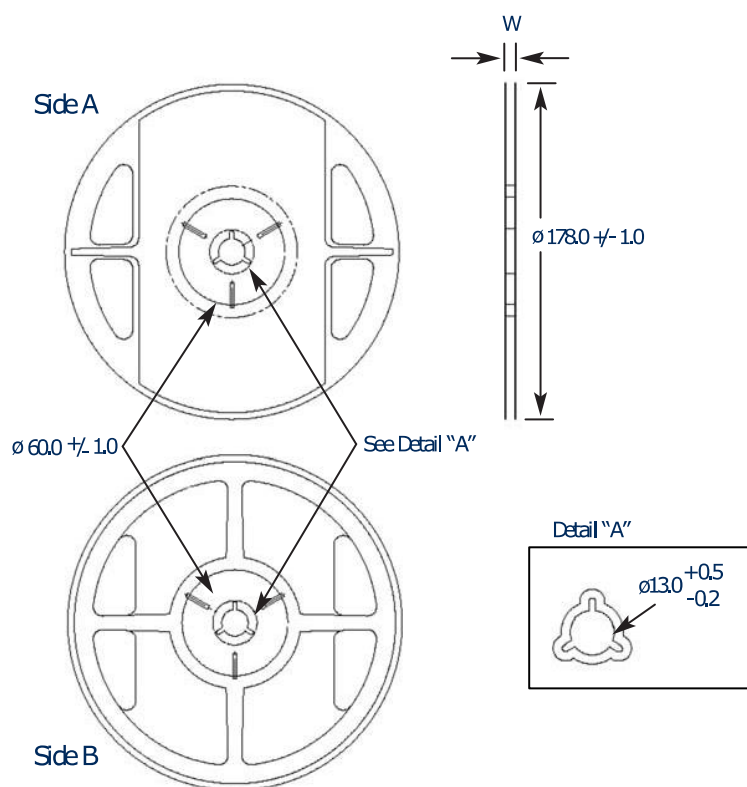

Figure 5: 7" reel

Note1: All dimensions in mm

Note2: 16mm reel's flanges are identical (Side A)

Hub standard width (W)

8mm

12mm

16mm

4.2 13"



Figure 6: reels 13"

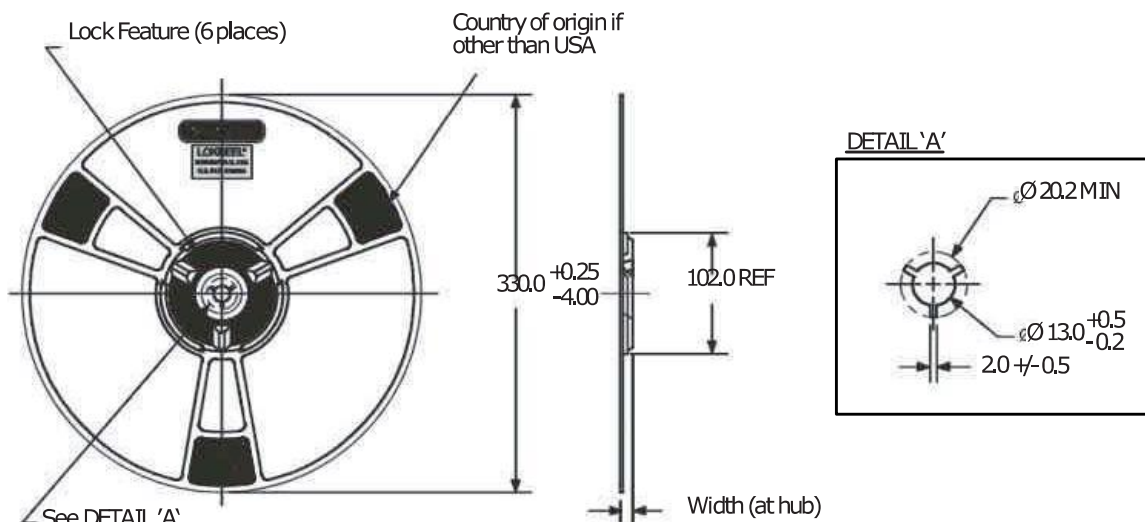

Figure 7: 13" reel (4-inch hub)

Note1: All dimensions in mm

Available Hub standard width	combination
8mm	4mm and 4mm
12mm	4mm and 8mm
16mm	8mm and 8mm
24mm	8mm and 16mm
44mm	16mm and 28mm

5 Dry-pack

5.1 Moisture Sensitivity

Plastic IC packages absorb moisture from the surrounding environment. This is a typical characteristic of the materials (mold compound and die attach) used in the construction of plastic packages. The moisture inside the package increases or decreases to reach the relative humidity (RH) of the surrounding environment.

Moisture inside the package turns into steam when the package is exposed to the vapor phase/infrared reflow and/or wave-soldering processes that are common in the fabrication of printed circuit boards (PCBs). The resulting steam and vapor pressure can cause cracking of the package, a phenomenon called popcorning.

5.2 Dry packaging

Dry packing consists of baking the packages to reduce moisture to a level not to exceed 0.05% by weight. Then, the units are placed in a moisture-barrier bag, along with desiccant, to keep the moisture inside the bag to a level <20% RH. Each product is labeled as moisture sensitive, outlining the necessary precautions for handling the product.

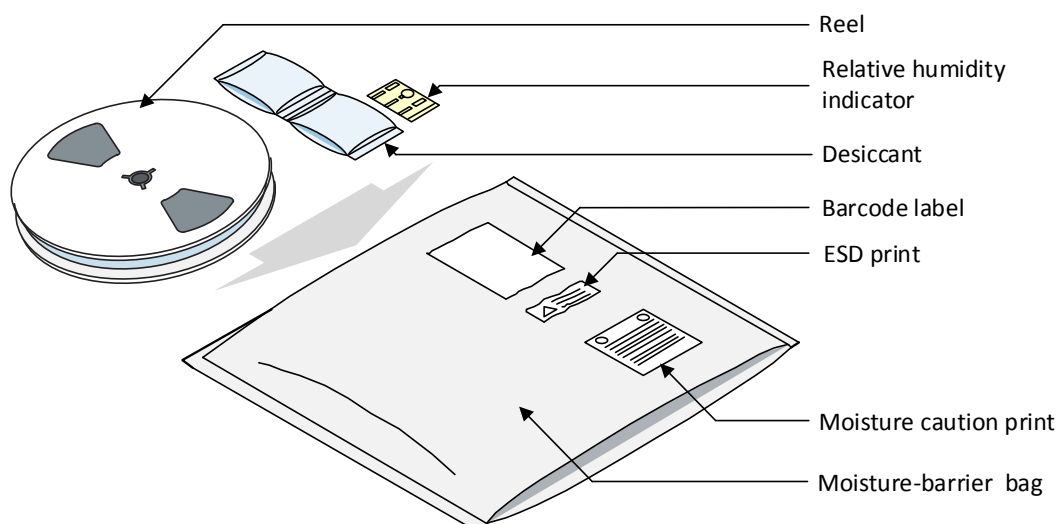

6 Contact Information

Buy our products or get free samples online at:

www.ams.com/ICdirect

Technical Support is available at:

www.ams.com/Technical-Support

Provide feedback about this document at:

www.ams.com/Document-Feedback

For further information and requests, e-mail us at:

ams_sales@ams.com

For sales offices, distributors and representatives, please visit:

www.ams.com/contact

Headquarters

ams AG

Tobelbaderstrasse 30

8141 Premstaetten

Austria, Europe

Tel: +43 (0) 3136 500 0

Website: www.ams.com

7 Copyrights & Disclaimer

Copyright ams AG, Tobelbader Strasse 30, 8141 Premstaetten, Austria-Europe. Trademarks Registered. All rights reserved. The material herein may not be reproduced, adapted, merged, translated, stored, or used without the prior written consent of the copyright owner.

Information in this document is believed to be accurate and reliable. However, ams AG does not give any representations or warranties, expressed or implied, as to the accuracy or completeness of such information and shall have no liability for the consequences of use of such information.

Applications that are described herein are for illustrative purposes only. ams AG makes no representation or warranty that such applications will be appropriate for the specified use without further testing or modification. ams AG takes no responsibility for the design, operation and testing of the applications and end-products as well as assistance with the applications or end-product designs when using ams AG products. ams AG is not liable for the suitability and fit of ams AG products in applications and end-products planned.

ams AG shall not be liable to recipient or any third party for any damages, including but not limited to personal injury, property damage, loss of profits, loss of use, interruption of business or indirect, special, incidental or consequential damages, of any kind, in connection with or arising out of the furnishing, performance or use of the technical data or applications described herein. No obligation or liability to recipient or any third party shall arise or flow out of ams AG rendering of technical or other services.

ams AG reserves the right to change information in this document at any time and without notice.

8 Revision Information

Changes from previous version to current revision 1-00 (2016-Apr-27)	Page
Initial version 1-00	

Note: Page numbers for the previous version may differ from page numbers in the current revision.
Correction of typographical errors is not explicitly mentioned.