

4

3

2

1

THIS DRAWING IS UNPUBLISHED. RELEASED FOR PUBLICATION
 © COPYRIGHT BY TYCO ELECTRONICS CORPORATION. ALL RIGHTS RESERVED.

LOC		DIST		REVISIONS			
P	LTR	DESCRIPTION		DATE	DWN	APVD	
DW	-	B	REVISED PER ECO-20-010284	28MAY21	DS	HL	

NOTES:

- MATERIAL:
HOUSING: PA66 WITH 25% GF, UL 94V-0, COLOR: IVORY.
CONTACTS: BRASS.
- FINISH:
CONTACTS: 2.54um [100u"] MIN. BRIGHT-TIN PLATED,
1.27um [50u"] MIN. NICKEL UNDERPLATED ALL OVER.
- RECOMMENDED PCB THICKNESS: 1.6mm.
- WAVE SOLDER CAPABLE TO 265°C PER TYCO TEST SPEC. 109-202, CONDITION B.

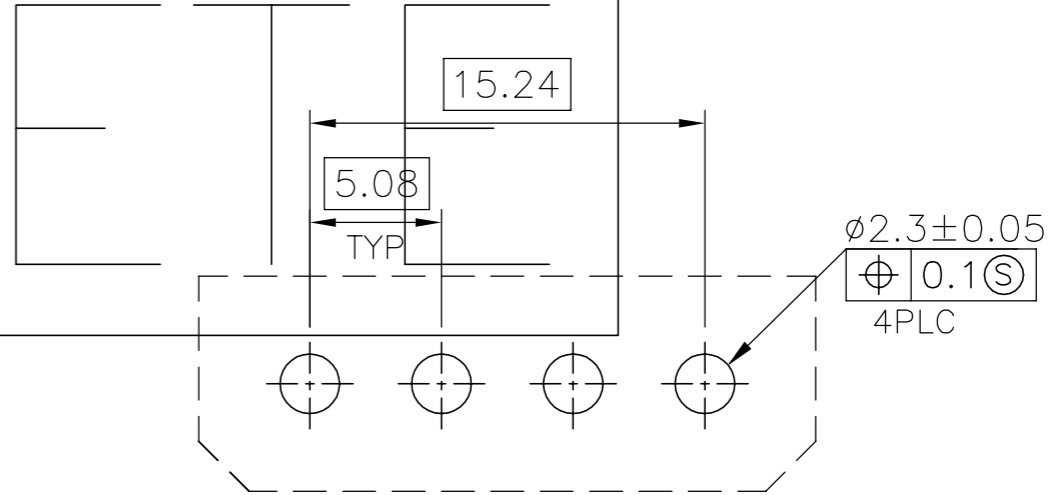
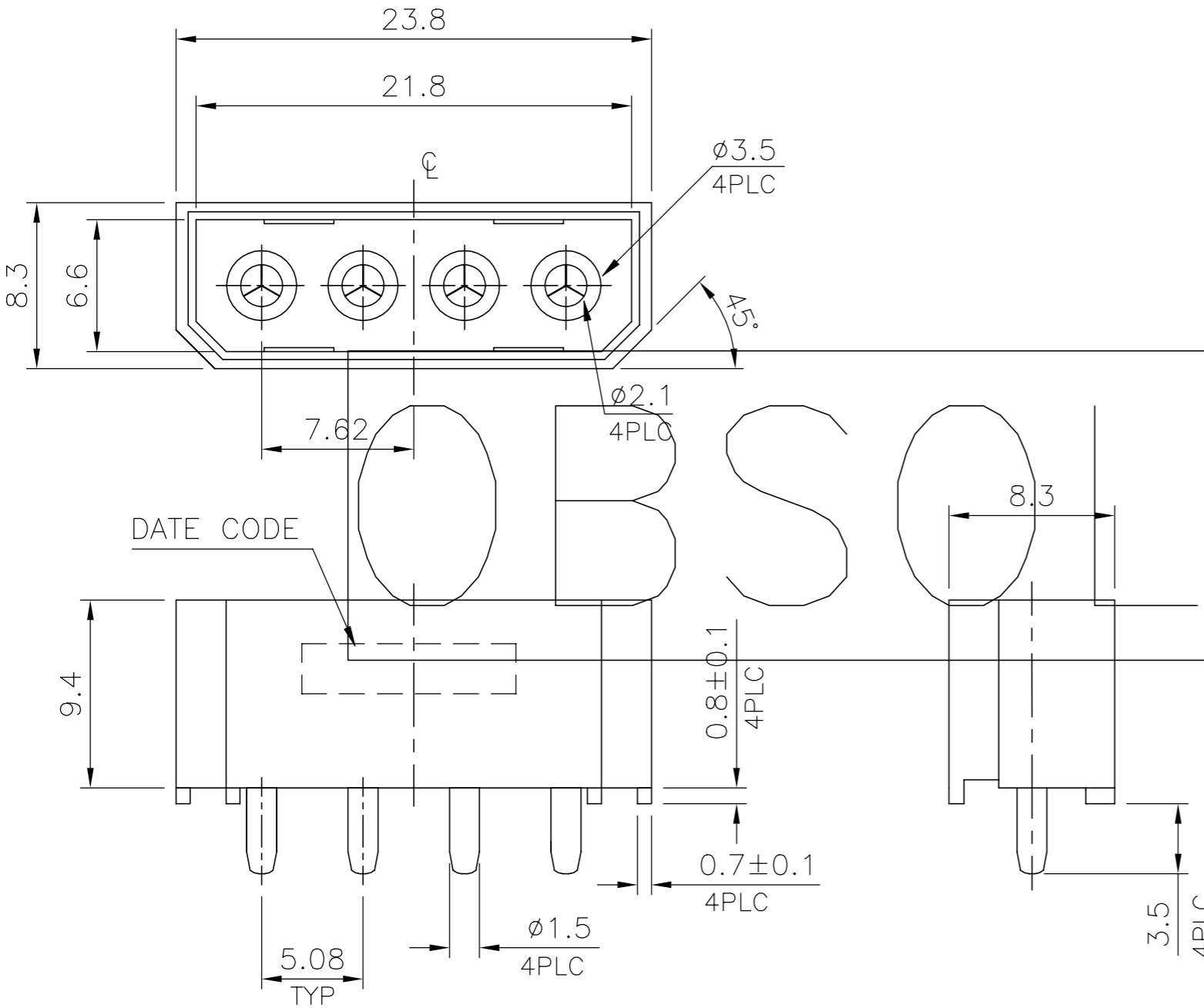

TOLERANCE: ±0.05
RECOMMENDED PCB LAYOUT

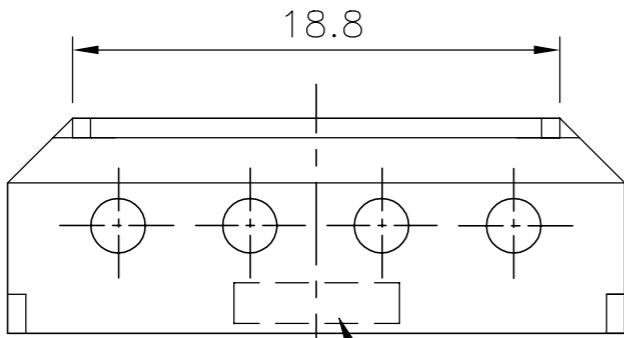

1734724-1
PART NUMBER

THIS DRAWING IS A CONTROLLED DOCUMENT.		DWN J. LEE 16MAR2007	tyco Tyco Holdings (Bermuda)	
DIMENSIONS: MM		CHK S. HOU 16MAR2007	Electronics VII Ltd. Taiwan Branch	
TOLERANCES UNLESS OTHERWISE SPECIFIED:		APVD W.J. KE 16MAR2007	NAME	
0 PLC ± -		PRODUCT SPEC	POWER CONNECTOR, 5.08mm PITCH, 4 POS, VERTICAL, DIP	
1 PLC ± 0.30		108-57641	RESTRICTED TO	
2 PLC ± 0.25		QUALIFICATION TEST REPORT	SIZE	CAGE CODE
3 PLC ± 0.15		501-57747	A3	00779
4 PLC ± -		WEIGHT 1.7 GRAMS	DRAWING NO C=1734724	
ANGLES ± 3°		CUSTOMER DRAWING	SCALE -	SHEET 1 OF 2
MATERIAL SEE NOTE	FINISH SEE NOTE	DRAWING NO		REV B

4

3

2

1

THIS DRAWING IS UNPUBLISHED.

RELEASED FOR PUBLICATION

LOC

DIST

REVISIONS

© COPYRIGHT BY TYCO ELECTRONICS CORPORATION. ALL RIGHTS RESERVED.

DW

P

LTR

DESCRIPTION

DATE

DWN

APVD

SEE SHEET 1

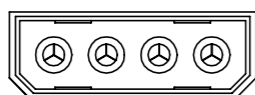

PRODUCT.

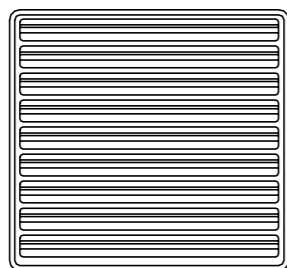

TRAY LAYOUT

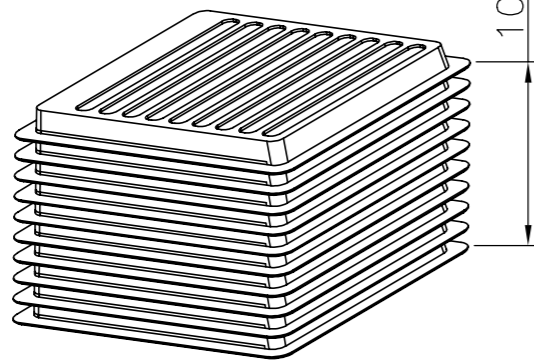

10 TRAYS

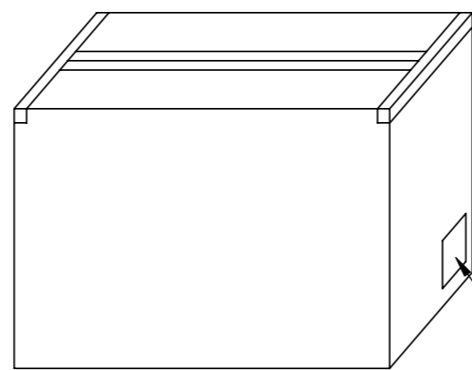

LABEL

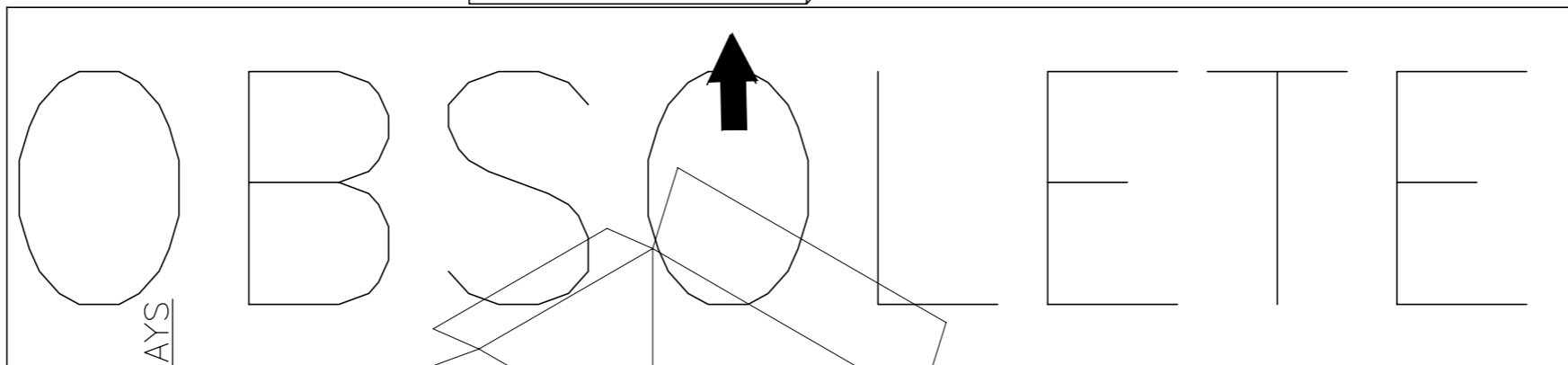

SHIPPING CARTON

NOTES:

- 1. DIMENSION:
TRAY: 425 X 280 X 30 mm
SHIPPING CARTON: 450 X 300 X 300 mm
- 2. QUANTITY:
(SEE TABLE)
- 3. WEIGHT:
(SEE TABLE)

8.5 KG	7.3 KG	432	4320
GROSS WEIGHT	NET WEIGHT	PCS/TRAY	PCS/CARTON

THIS DRAWING IS A CONTROLLED DOCUMENT.		DWN J. LEE 16MAR2007	tyco Tyco Holdings (Bermuda)	
		CHK S. HOU 16MAR2007	<i>Electronics</i> VII Ltd. Taiwan Branch	
		APVD W.J. KE 16MAR2007	NAME	
DIMENSIONS: MM		PRODUCT SPEC		
TOLERANCES UNLESS OTHERWISE SPECIFIED:		QUALIFICATION TEST REPORT		
0 PLC ±		SIZE		
1 PLC ±		CAGE CODE		
2 PLC ±		DRAWING NO		
3 PLC ±		RESTRICTED TO		
4 PLC ±		A3 00779 C=1734724		
ANGLES ±		SCALE		
MATERIAL		SHEET 2 of 2		
FINISH		REV B		
		CUSTOMER DRAWING		