

Verpackt im Gurt nach DIN IEC 60286-3
 Tape on Reel Packaging according to DIN IEC 60286-3
 Verpackungseinheit: 400 Stück
 Packaging unit: 400 pcs

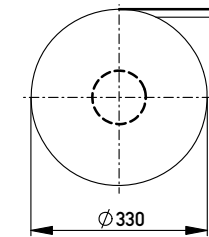

Abspulrichtung - Reel off Direction

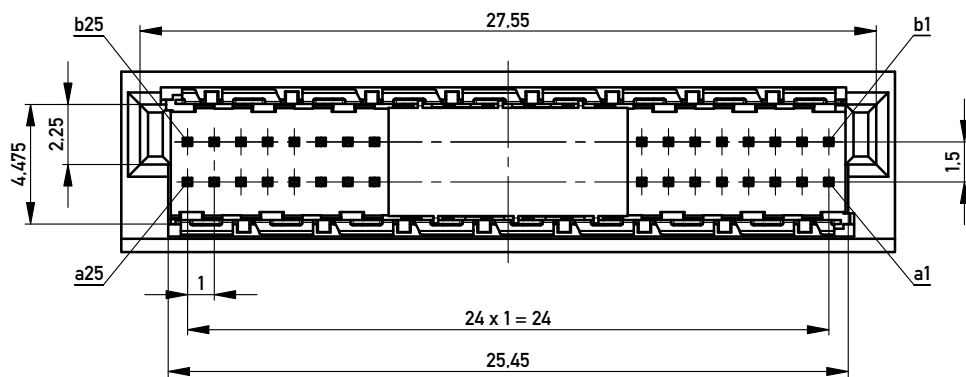

Leiterplatten-Layout Vorschlag / PCB-layout proposal

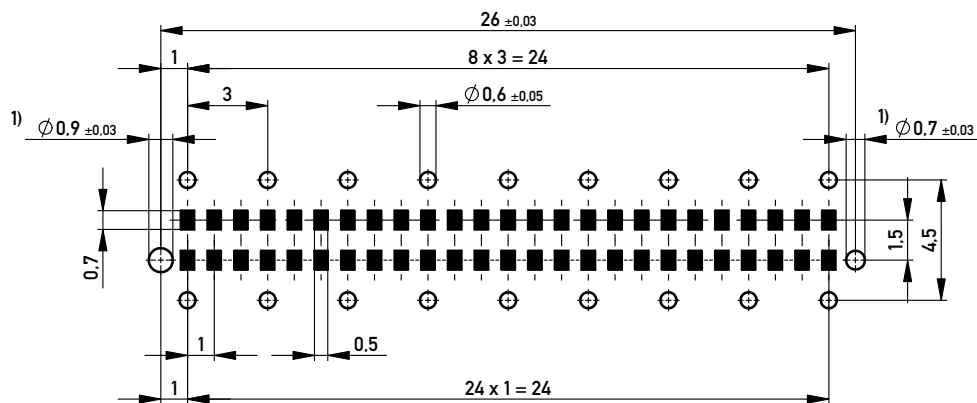

1) Durchmesser des Bohrers / drill tool

Anforderungsstufe 1
 Performance Level 1

Kontaktbereich vergoldet
 Mating Area gold plating

Anschlussbereich verzinnt 4-6 µm
 Terminal Area 4-6 µm tin plating

Koplanarität der Anschlüsse ≤ 0.1 mm
 Coplanarity Area of Termination ≤ 0.1 mm

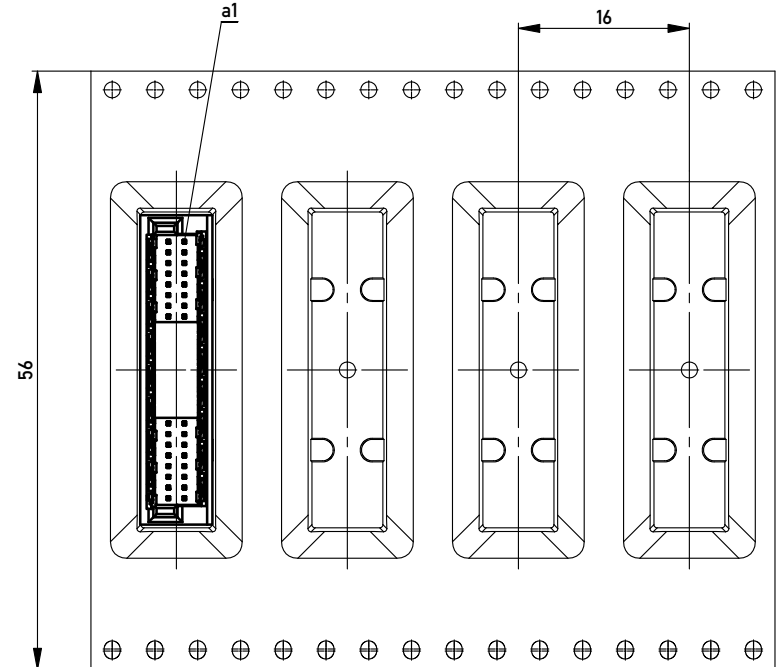

Information:		Tolerances	Scale 5:1
All rights reserved. Only for Information. To ensure that this is the latest version of this drawing, please contact one of the ERNI companies before using.		All Dimensions in mm	Designation M02 MSpeed Blind Mate 50 THR
Copyright by ERNI GmbH. Proprietary notice pursuant to ISO 9006 to be observed.		www.ERNI.com	354184
f	28.01.2014	Class MSPEED	
Index	Date	I A3	