

THIS DRAWING IS UNPUBLISHED. RELEASED FOR PUBLICATION
 © COPYRIGHT - By - ALL RIGHTS RESERVED.

LOC		DIST		REVISIONS			
P	LTR	DESCRIPTION		DATE	DWN	APVD	
DF	A0	M		REVISED PER ECO-14-012828	28AUG2014	MGM	CT

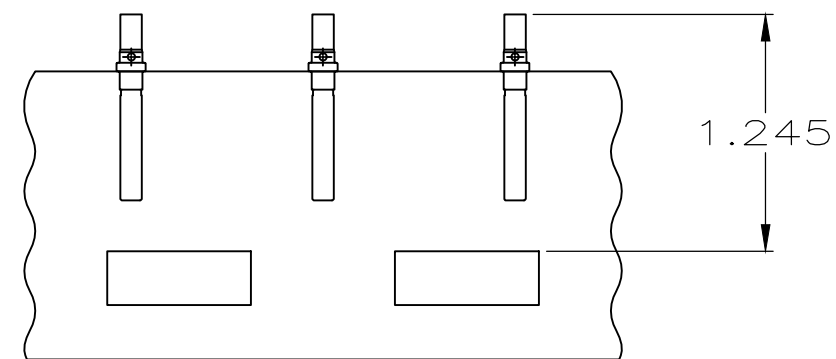

TAPE MOUNTED ASSEMBLY (-2 ONLY)

- 205117-1 1. AS SHOWN
- OBSOLETE 205117-2 1. SAME AS -1 EXCEPT: MOUNTED ON MYLAR TAPE.
- 205117-3 1. SAME AS -1 EXCEPT: COLOR CODE TO BE SINGLE BLUE BAND.

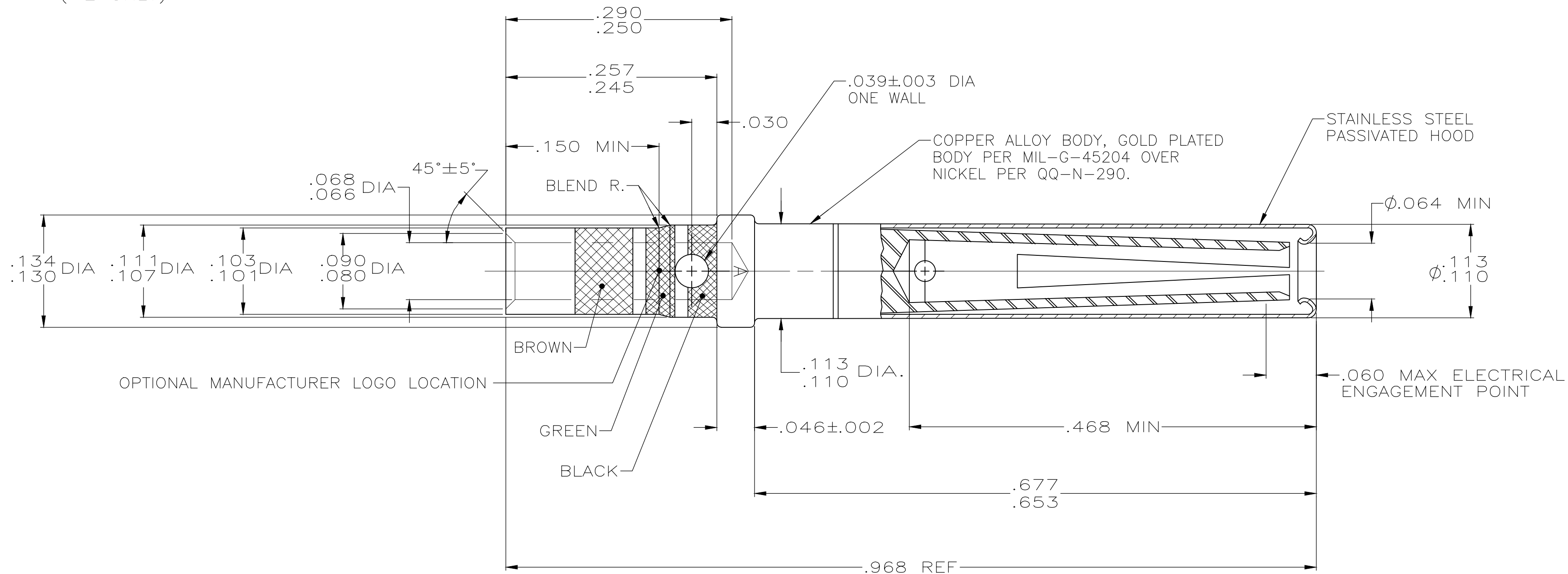

1. WHEN ORDERING CONTACT ON TAPE, ORDER BY THE TAPE NUMBER PLUS THE PACKAGING CODE AS FOLLOWS:
 1. FOR USE WITH AMP TAPETRONIC, PNEUMATIC TOOL-
 - A. 1000 PARTS TO A BOX ADD PACKAGING CODE: 1MBOX
 2. FOR USE WITH 4/8 INDENT STRIPPER CRIMPER-
 - A. 1000 PARTS TO A REEL ADD PACKAGING CODE: 1MREEL
 - B. 5000 PARTS TO A REEL ADD PACKAGING CODE: 5MREEL
2. POINT OF PLATING THICKNESS MEASUREMENT .100/.150 FROM WIRE BARREL END EXTERIOR.

THIS DRAWING IS A CONTROLLED DOCUMENT.		DWN	J.LINDERMAN	3-24-93		TE Connectivity	
DIMENSIONS: INCHES		CHK	A.SHARPE	3-26-93		CONTACT ASS'Y #16 SOCKET ARINC 404 REAR RELEASE	
TOLERANCES UNLESS OTHERWISE SPECIFIED:		APVD	-	-	NAME	-	
0 PLC ± -		PRODUCT SPEC	-			SIZE	A2
1 PLC ± -		APPLICATION SPEC	-			CAGE CODE	00779
2 PLC ± -		WEIGHT	-			DRAWING NO	C-205117
3 PLC ± .005		CUSTOMER DRAWING	-			SCALE	10:1
4 PLC ± -		FINISH	-			SHEET	1 OF 1
ANGLES ± -		REVISIONS	-			REV	M