

REVISIONS			
P. LTR	DESCRIPTION	DATE	DRW. APD
AE3	REVISED PER ECR-21-103273	13MAY2021	RZ WK

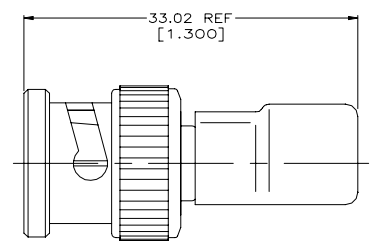

VIEW B  
SAME AS VIEW A EXCEPT AS SHOWN

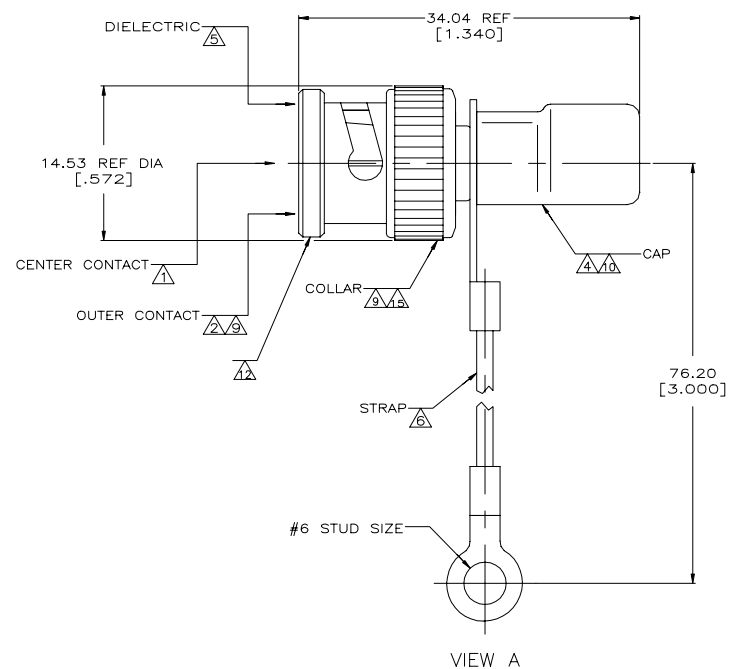
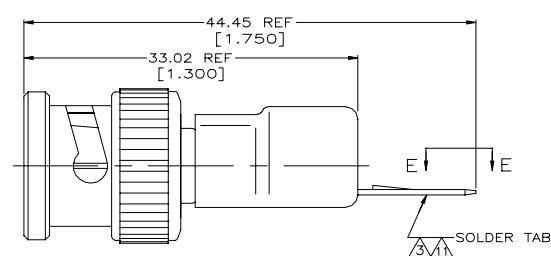

VIEW D  
SAME AS VIEW A EXCEPT AS SHOWN

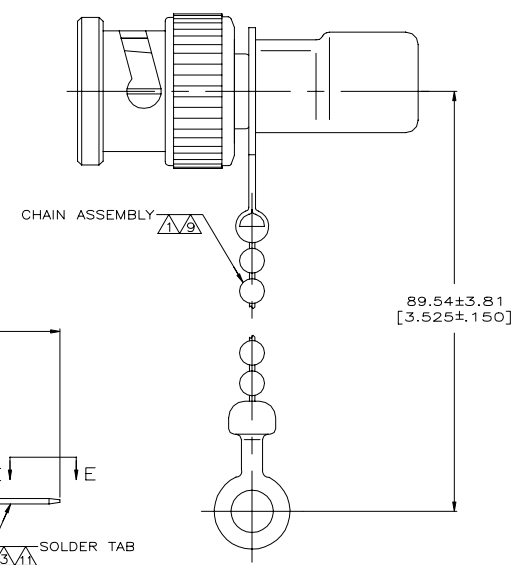

VIEW C  
SAME AS VIEW A EXCEPT AS SHOWN

- 1 BRASS PER QQ-B-626.
- 2 BRASS PER MIL-C-21768.
- 3 BRASS PER MIL-C-50.
- 4 COPPER PER QQ-C-576.
- 5 POLYETHYLENE PER LP-390.
- 6 POLYESTER PER MIL-T-43435, COLOR NATURAL.
- 7 GOLD PLATE PER MIL-G-45204, 0.76 μm [.000030] MINIMUM THICK.
- 8 SILVER PLATE PER QQ-S-365, 2.54 μm [.000100] MINIMUM THICK.
- 9 NICKEL PLATE PER QQ-N-290, 1.27 μm [.000050] MINIMUM THICK.
- 10 TIN PLATE PER ASTM B 545, 2.54 μm [.000100] MIN THICK.
- 11 TIN PLATE PER ASTM B 545, 3.81 μm [.000150] MINIMUM THICK.
- 12 VALUE MARKED ON CONNECTOR BODY AS SHOWN. (SEE TABLE)
- 13 SEE SEPARATE RESTRICTED CUSTOMER DRAWING WITH THIS PART NUMBER.
- 14 16 GAUGE INSULATED GROUND WIRE.
- 15 ZINC PER QQ-Z-363

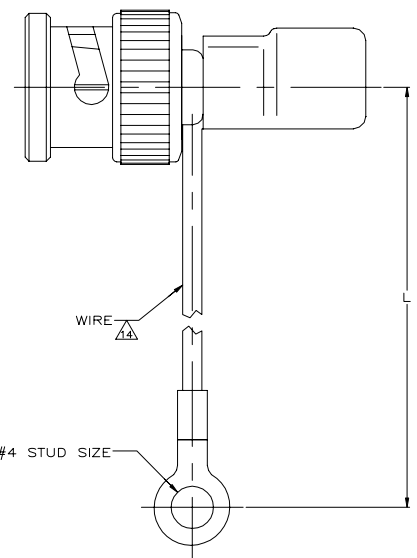

VIEW F  
SAME AS VIEW A EXCEPT AS SHOWN

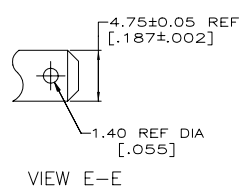

VIEW E-E

QTY	WATT	TOLERANCE	OHM	MARKING	L	CENTER CONTACT PLATING	VIEW	PART NUMBER
OBSOLETE	1	1%	50	50Ω 1W	-	△	B	9-221629-1
OBSOLETE	1	1%	50	50Ω 1W	-	△	A	9-221629-0
OBSOLETE	-	1%	50	50Ω 1W	2999.99±25.40 [118.11±1.00]	△	F	2-221629-2
OBSOLETE	△	-	-	-	-	-	-	2-221629-1
OBSOLETE	△	-	-	-	-	-	-	2-221629-0
OBSOLETE	△	-	-	-	-	-	-	1-221629-9
OBSOLETE	1	1%	50	50Ω 1W	-	△	B	1-221629-8
OBSOLETE	1	1%	50	50Ω 1W	85.85±2.03 [3.38±.080]	△	F	1-221629-6
OBSOLETE	1	1%	50	-	-	△	D	1-221629-2
OBSOLETE	.5	1%	75	75Ω .5W	-	△	C	1-221629-1
OBSOLETE	1	1%	50	50Ω 1W	-	△	B	221629-9
OBSOLETE	1	1%	50	50Ω 1W	-	△	B	221629-8
OBSOLETE	.5	5%	100	100Ω .5W	-	△	B	221629-7
OBSOLETE	1	1%	93	93Ω 1W	-	△	B	221629-6
OBSOLETE	1	1%	75	75Ω 1W	-	△	B	221629-5
OBSOLETE	1	1%	50	50Ω 1W	-	△	B	221629-4
OBSOLETE	1	1%	93	93Ω 1W	-	△	A	221629-3
OBSOLETE	1	1%	75	75Ω 1W	-	△	A	221629-2
OBSOLETE	1	1%	50	50Ω 1W	-	△	A	221629-1

THIS DRAWING IS A CONTROLLED DOCUMENT. DRN LIPPERT 9-22-90  
 DRW E. RUTH 9-28-90  
 AND M. PHILLIPS 10-1-90

TE Connectivity  
 TERMINATOR, PLUG, COMMERCIAL BNC

APPLICATOR SPEC: 0.000000  
 WEIGHT: 0.000000  
 MATERIAL: -  
 FINISH: -

SIZE: A1  
 CASE CODE: 00779  
 DRAWING NO: 221629  
 RESTRICTED TO: -  
 CUSTOMER DRAWING: -  
 SCALE: 4:1  
 SHEET: 1 OF 1  
 REV: AF3