

3400
3500



e-chain system® E2/000 Series 3400/3500



Price Index



Series 3400/3500

Special Features / Options



IPA Qualification Certificate, Air Cleanliness Class ISO Class 3 (at v = 2 m/s) upon request



ESD classification: Electrically conductive ESD/ATEX version upon request



UL94 V2 classifications upon request

Assembly Tips



Snap-open mechanism, choice of snap-open on left or right. Hinged crossbar can be swiveled by more than 180° on both sides. Lightning-fast closing by hand. Secure fit without additional locking devices.

Other Installation Methods

Vertical, hanging ≤ 262 ft (80 m)

Vertical, standing ≤ 9.84 ft (3 m)

Side-mounted, un_supp. ≤ 3.28 ft (1 m)

Rotary requires further calculation

Usage Guidelines



- If snap-open accessibility along the inner or outer radius is required
- If integrated strain relief at the mounting point is required
- If modular interior separation is needed
- If long service life is required
- If easy installation is required



- If the application is very simple
➤ Series E300 E-Z Chain
- If greater stability is required
➤ Series E4-42 E4-1 Series

Features & Benefits

- 1 Tried-and-tested mounting bracket
- 2 Snap-open crossbar for easy opening from the left or right
- 3 Series 3500 snap-open on both sides along outer radius
- 4 Series 3400 snap-open on both sides along inner radius
- 5 Integrated strain relief possible
- 6 Modular interior separation
- 7 Easy assembly by optimized pin
- 8 Double stop dog for long unsupported length
- 9 Crossbars with high retention force
- 10 Also available as ESD version
- 11 Strain relief separator available

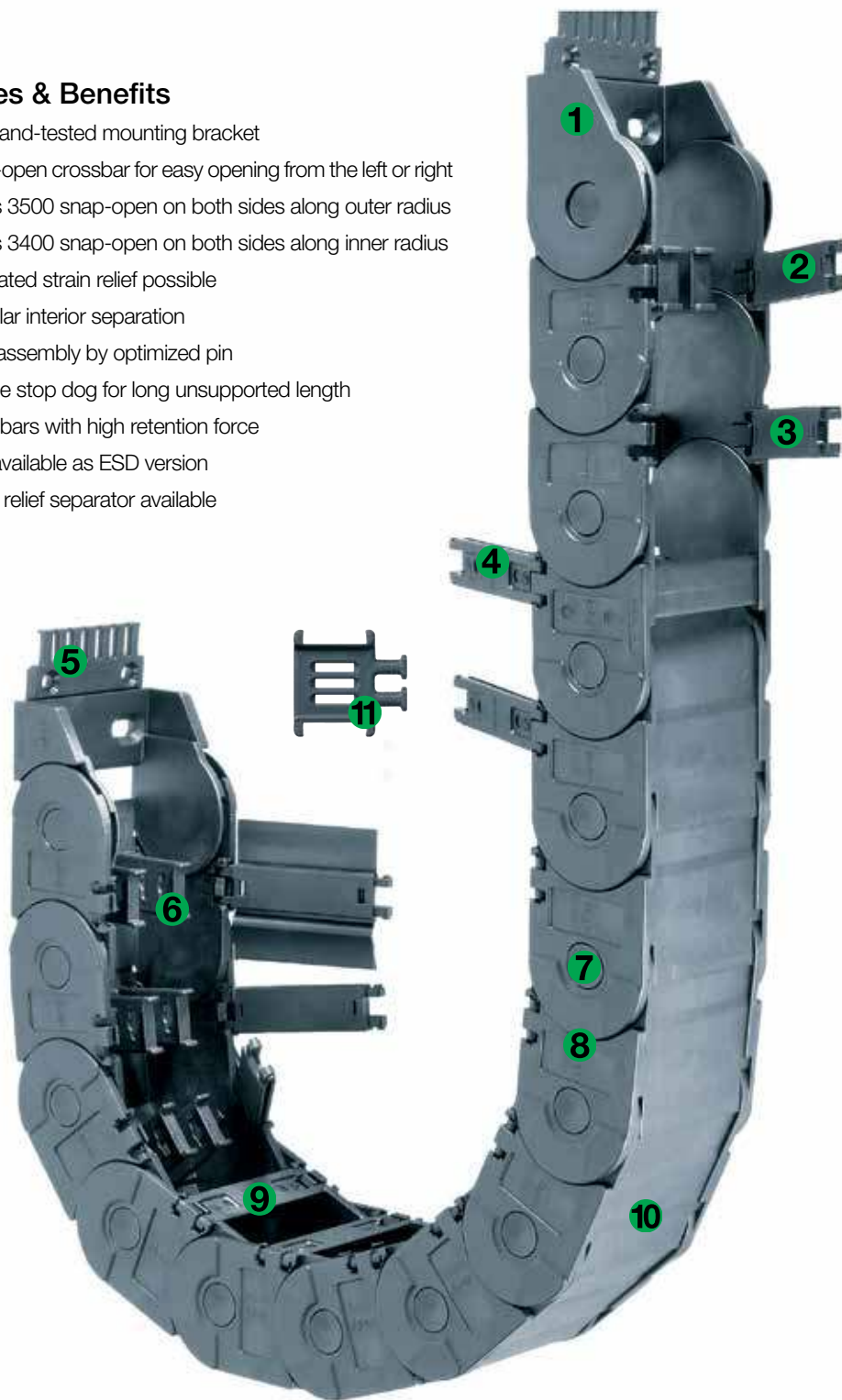

Order Example: Complete e-chain®

Please indicate chain length or number of links. Example:

9.84 ft (3 m) **3400-100-100-0**



e-chain®

With 2 separators **45.1.1** assembled every 2nd link



Interior Separation

1 Set **3100-34PZB**



Mounting Bracket

e-chain system® E2/000

Series 3400/3500

Installation Dimensions

Short travel, unsupported length

- FL_B = unsupported with permitted sag
 - FL_G = unsupported with straight upper run
- Further information ► Design, Chapter 1

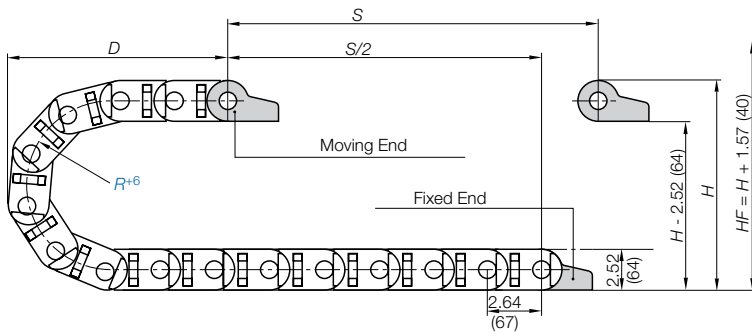
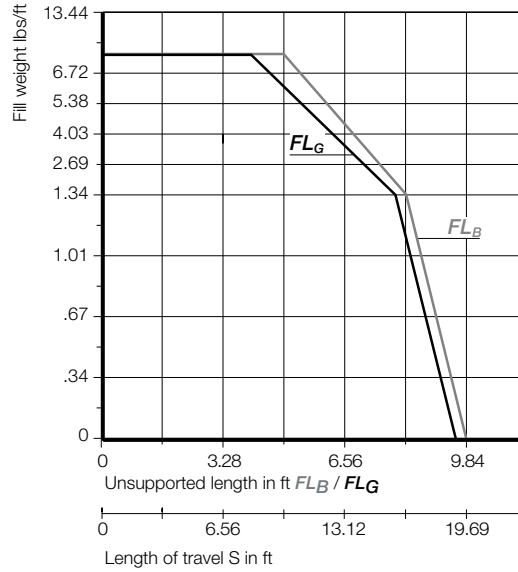
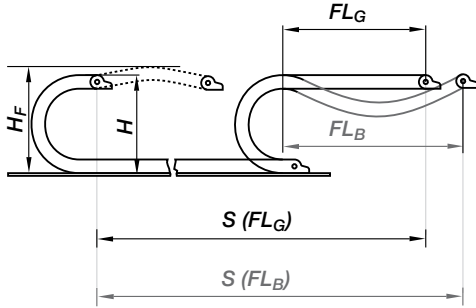

Pitch per link: = 2.64" (67 mm)
 Links per ft (m): = 4.57 (15)
 For center mount applications:
 Chain length = $S/2 + K$

The required clearance height: $H_f = H + 1.57$ in. (40 mm) (with 1.68 lbs/ft (2.5 kg/m) fill weight).
 Please consult igus® if space is particularly restricted.

R	1.50 (075)	3.94 (100)	4.92 (125)	5.91 (150)	7.87 (200)	9.84 (250)	11.81 (300)
H	8.43 (214)	10.39 (264)	12.36 (314)	14.33 (364)	18.27 (464)	22.20 (564)	26.14 (664)
D	8.19 (208)	9.17 (233)	10.16 (258)	11.14 (283)	13.11 (333)	15.08 (383)	17.05 (433)
K	14.57 (370)	17.72 (450)	20.87 (530)	24.02 (610)	30.11 (765)	36.22 (920)	42.52 (1080)

For long travels with lowered mounting height

Long travel lengths from 32.8 ft. (10 m) to max. 492 ft. (150 m)

For long travels, igus® specifies Series 3500 that snap open on the outer radius.

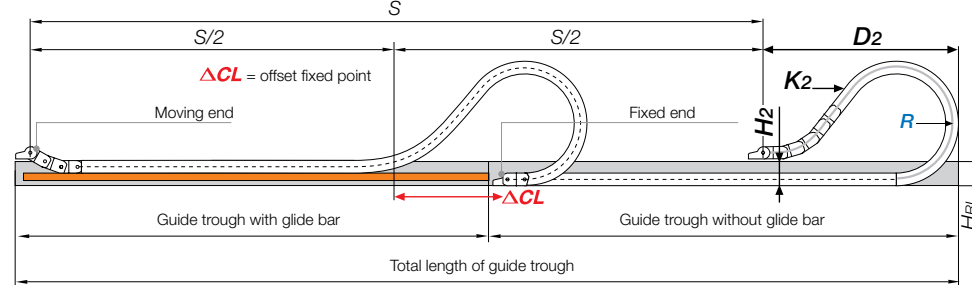

For center mount applications:
 Chain length: = $S/2 + K_2$

R	1.50 (075)	3.94 (100)	4.92 (125)	5.91 (150)	7.87 (200)	9.84 (250)	11.81 (300)
H_2	5.91 (150)	7.87 (200)	7.32 (186)	7.32 (186)	7.32 (186)	7.32 (186)	7.32 (186)
D_2^{25}	8.19 (208)	9.17 (233)	18.70 (475)	22.44 (570)	30.71 (780)	39.76 (1010)	45.28 (1150)
K_2	14.57 (370)	17.72 (450)	31.65 (804)	39.57 (1005)	52.76 (1340)	65.94 (1675)	76.50 (1943)
ΔCL	—	—	9.17 (233)	11.93 (303)	18.23 (463)	25.31 (643)	28.86 (733)

Speed / acceleration FL_G	max. 65.6 ft/s (20 m/s) / max. 656 ft/s ² (200 m/s ²)
Speed / acceleration FL_B	max. 9.84 ft/s (3 m/s) / max. 19.69 ft/s ² (6 m/s ²)
Gliding speed / acceleration (maximum)	max. 32.8 ft/s (10 m/s) / max. 164 ft/s ² (50 m/s ²)
Material - permitted temperature	igumid G / -40°F (-40°C) up to +248°F (+120°C)
Flammability Class, igumid G	VDE 0304 IIC UL94 HB



3400
3500

Short Travels - Unsupported



Unsupported e-chains® feature positive camber over short travels. This must be accounted for when specifying the clearance height. Please refer to **Installation dimensions** for further details.

Legend

- S = Length of travel
- R = Bending radius
- H = Nominal clearance height
- D = Overlength e-chain® radius in final position
- $K = \pi \cdot R + \text{safety buffer}$
- H_f = Required clearance height
- H_{ri} = Trough inner height
- H_2 = *Mounting height
- D_2 = Overlength - long travels, gliding
- K_2 = *Add-on

*If the mounting bracket location is set lower

Long Travels - Gliding



If the unsupported length is exceeded, the e-chain® must glide on itself. This requires a guide trough. **Design, Chapter 1**

Technical Data



Details of material properties

► Chapter 1



PDF: igus.com/e-chain-pdfs
 Product information: igus.com/e-chains



Series 3400 - snap-open along the inner radius

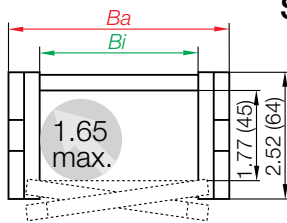

Part Number Structure

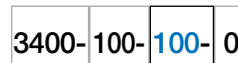

Color - Black
Bending radius
Width
Series

Series 3500 - snap-open along the outer radius

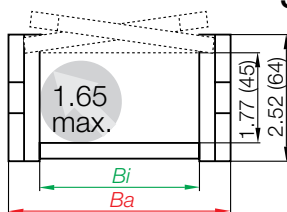

Part Number Structure



Color - Black
Bending radius
Width
Series

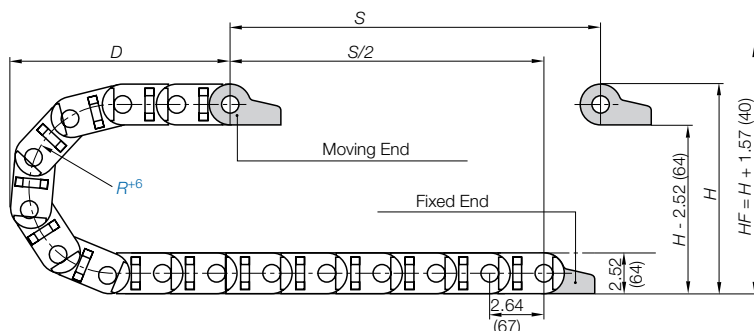

Supplement part number with required radius.
Example: 3500-100-100-0
Pitch: 264 in. (67 mm) per link links/ft(m) = 4.57 (15)

Part Number.

Snap-open inner radius	Snap-open outer radius	Bi in. (mm)	Ba in. (mm)	Weight lbs/ft (kg/m)
3400-050- <input type="text"/> -0	3500-050- <input type="text"/> -0	1.97 (50)	2.76 (70)	≈ 1.07 (1.60)
3400-075- <input type="text"/> -0	3500-075- <input type="text"/> -0	2.95 (75)	3.74 (95)	≈ 1.20 (1.78)
3400-100- <input type="text"/> -0	3500-100- <input type="text"/> -0	3.94 (100)	4.72 (120)	≈ 1.30 (1.93)
3400-115- <input type="text"/> -0	3500-115- <input type="text"/> -0	4.53 (115)	5.31 (135)	≈ 1.34 (1.99)
3400-125- <input type="text"/> -0	3500-125- <input type="text"/> -0	4.92 (125)	5.71 (145)	≈ 1.36 (2.03)
3400-150- <input type="text"/> -0	3500-150- <input type="text"/> -0	5.91 (150)	6.69 (170)	≈ 1.46 (2.17)
3400-175- <input type="text"/> -0	3500-175- <input type="text"/> -0	6.89 (175)	7.68 (195)	≈ 1.53 (2.28)
3400-200- <input type="text"/> -0	3500-200- <input type="text"/> -0	7.87 (200)	8.66 (220)	≈ 1.65 (2.45)
3400-225- <input type="text"/> -0	3500-225- <input type="text"/> -0	8.86 (225)	9.65 (245)	≈ 1.74 (2.59)
3400-250- <input type="text"/> -0	3500-250- <input type="text"/> -0	9.84 (250)	10.63 (270)	≈ 1.83 (2.73)

Choose from the radii below for all of the above sizes

Radius (mm) Example: 3500-100-100-0

	075	100	125	150	200	250	300
R	1.50 (075)	3.94 (100)	4.92 (125)	5.91 (150)	7.87 (200)	9.84 (250)	11.81 (300)
H	8.43 (214)	10.39 (264)	12.36 (314)	14.33 (364)	18.27 (464)	22.20 (564)	26.14 (664)
D	8.19 (208)	9.17 (233)	10.16 (258)	11.14 (283)	13.11 (333)	15.08 (383)	17.05 (433)
K	14.57 (370)	17.72 (450)	20.87 (530)	24.02 (610)	30.11 (765)	36.22 (920)	42.52 (1080)

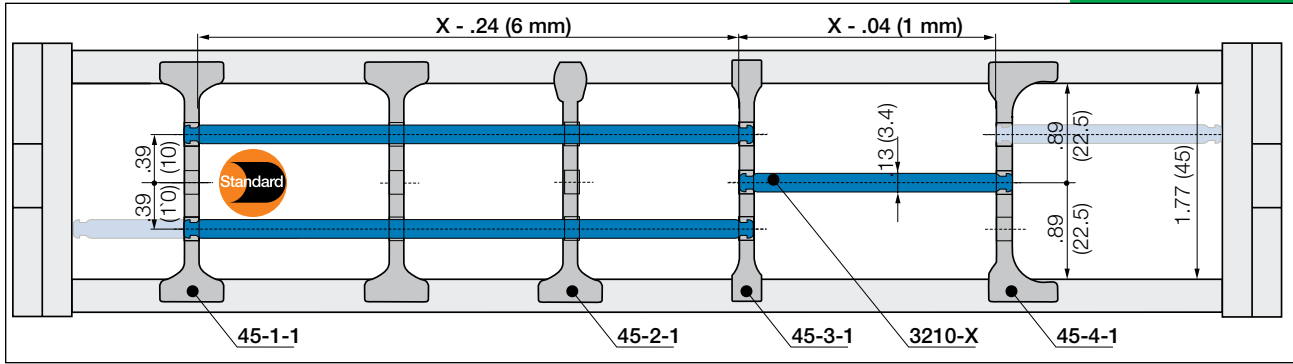

In the standard configuration separators are assembled every 2nd e-chain® link

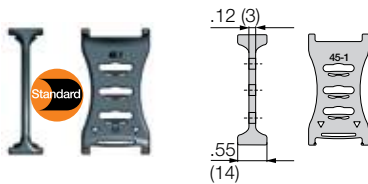

Separator, wide base

Unassembled	Part No. 45.1
Assembled	Part No. 45.1.1

- **Standard separator 45.1 for all applications**

Separator with wide base for maximum locking strength and safe standing in e-chains®.

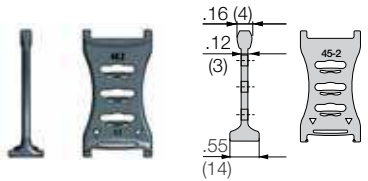

Separator, narrow head

Unassembled	Part No. 45.2
Assembled	Part No. 45.2.1

- **Separator 45.2**

For even faster installation

is used when vertical and horizontal separation is required. Due to its slot, it allows basic vertical/horizontal shelving arrangements.

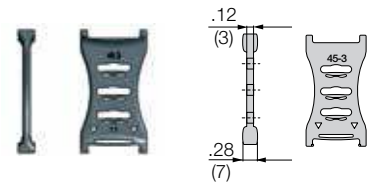

Separator, narrow base

Unassembled	Part No. 45.3
Assembled	Part No. 45.3.1

- **Separator 45.3**

For many thin cables

is used when vertical and horizontal separation is required. Due to its slot, it allows basic vertical/horizontal shelving arrangements.

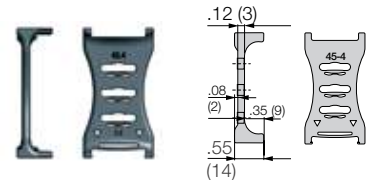

Separator, asymmetrical

Unassembled	Part No. 45.4
Assembled	Part No. 45.4.1

- **Separator 45.4**

For side mounted applications

is used when vertical and horizontal separation is required. Due to its slot, it allows basic vertical/horizontal shelving arrangements.

Lockable full-width shelves - for the standard interior separation

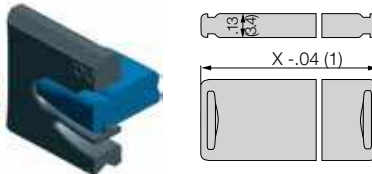

Full width shelf, lockable

Unassembled	Part No. 3200-X
Assembled	Part No. 3210-X

- **Full width shelf, lockable**

is used when vertical and horizontal separation is required.

Width X in. (mm)	Part No. Unassembled	Part No. Assembled	Width X in. (mm)	Part No. Unassembled	Part No. Assembled
1.97 (050)	3200-50	3210-50	5.91 (150)	3200-150	3210-150
2.95 (075)	3200-75	3210-75	6.89 (175)	3200-175	3210-175
3.94 (100)	3200-100	3210-100	7.87 (200)	3200-200	3210-200
4.53 (115)	3200-115	3210-115	8.86 (225)	3200-225	3210-225
4.92 (125)	3200-125	3210-125	9.84 (250)	3200-250	3210-250



3400
3500



e-chain system® E2/000
Series 3400/3500
Extender crossbars

igus®
e-chain system®

Telephone 1-800-521-2747

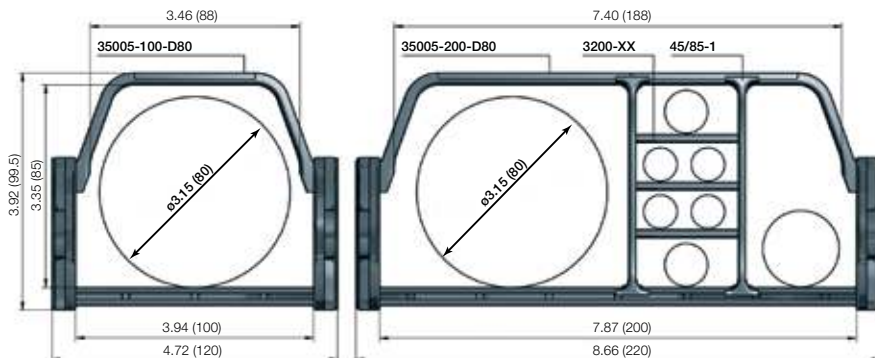

Part Number.

Extender crossbars
for e-chains®
that snap-open
along **inner** radius

Extender crossbars
for e-chains®
that snap-open
along **outer** radius

Bi

Ba

in. (mm)

in. (mm)

3400-100D80-□ -0	3500-100D80-□ -0	2.95 (100)	3.58 (120)
3400-200D80-□ -0	3400-200D80-□ -0	4.92 (200)	5.55 (220)

Choose from the radii below for all of the above sizes

Radius (mm)		Example: 2700-10D58-□ -0	
R	075*	100*	125
	2.95 (075)	3.94 (100)	4.92 (125)
		150	200
		5.91 (150)	6.89 (175)
		250	300
		7.87 (200)	9.84 (250)

*Radius 075 and 100 are only available for Series 3500 e-chains®

Interior separation for extender crossbars

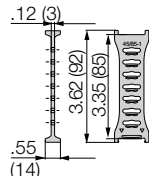

Separator, wide base

Unassembled	Part No. 45/85.1
Assembled	Part No. 45/85.1.1

- **Standard separator 45/85.1, wide base**
For maximum locking strength and safe standing. In standard configuration separators are assembled every 2nd e-chain® link.

Lockable full-width shelves - for the standard interior separation

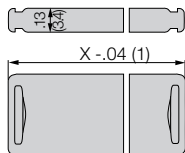

Full width shelf, lockable

Unassembled	Part No. 3200-X
Assembled	Part No. 3210-X

- **Full width shelf, lockable**
is used when vertical and horizontal separation is required.

Width X in. (mm)	Part No. Unassembled	Part No. Assembled	Width X in. (mm)	Part No. Unassembled	Part No. Assembled
1.97 (050)	3200-50	3210-50	5.91 (150)	3200-150	3210-150
2.95 (075)	3200-75	3210-75	6.89 (175)	3200-175	3210-175
3.94 (100)	3200-100	3210-100	7.87 (200)	3200-200	3210-200
4.53 (115)	3200-115	3210-115	8.86 (225)	3200-225	3210-225
4.92 (125)	3200-125	3210-125	9.84 (250)	3200-250	3210-250

Separator with integrated strain relief

Strain relief separator Part No. 301-Z can be integrated into the mounting bracket and can be placed there at any point of the e-chain®. It combines strain relief and interior separation, it can be installed on the first or last e-chain® link and is easy to assemble without any screws.



For more information ► Chapter 10, Strain Relief

Internet: igus.com
email: sales@igus.com
QuickSpec: igus.com/quickspec

e-chain system® E2/000

Series 3400/3500

Mounting Bracket - Plastic



3400
3500

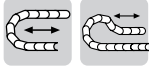

Option 1: pivoting

- For unsupported and gliding applications
- Well suited for tight installation conditions
- Detachable strain relief tiwrap plates
- Can be mounted on the fixed and/or moving end

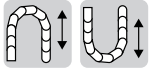

Option 2: locking

- For unsupported and gliding applications
- Extreme speed and/or accelerations
- For height restricted applications
- Can be mounted on the fixed and/or moving end



Part Number Structure

3075- 34 PZB K1

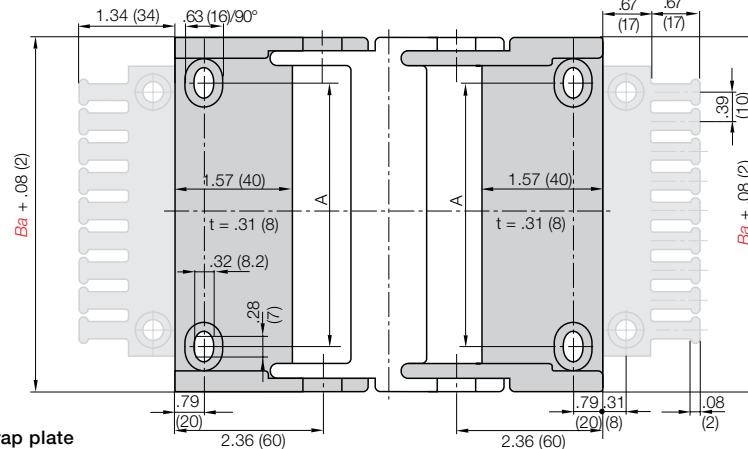
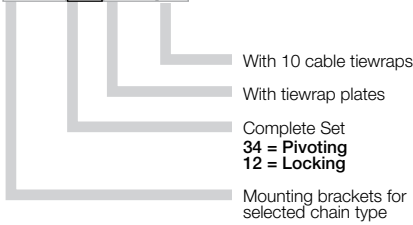

Full set, for both ends:

3075- [34] PZB Full set, each part with pin/bore + tiwrap plate

Single-part order:

3075- [3] PZB Mounting bracket with bore + tiwrap plate

3075- [4] PZB Mounting bracket with pin + tiwrap plate

Part No. Full Set (pivoting)

Without Tiwrap Plates

Series 3400:

3075-34PZ

Part No. Full Set (pivoting)

With Tiwrap Plates

Series 3400:

3075-34PZB

Part No. Full Set (pivoting)

With Tiwrap Plates + 10 cable ties

Series 3400:

3075-34PZBK1

For Chain Type	Part No. Full Set without Tiwrap Plate	Part No. Full Set with Tiwrap Plate	Part No. Full Set with Tiwrap Plate + 10 cable ties	Dimension A in. (mm)	Number of Teeth
3400/3500-050	3050- [] PZ	3050- [] PZB	3050- [] PZBK1	2.09 (28)	5
3400/3500-075	3075- [] PZ	3075- [] PZB	3075- [] PZBK1	2.09 (53)	7
3400/3500-100	3100- [] PZ	3100- [] PZB	3100- [] PZBK1	3.07 (78)	10
3400/3500-115	3115- [] PZ	3115- [] PZB	3115- [] PZBK1	3.66 (93)	11
3400/3500-125	3125- [] PZ	3125- [] PZB	3125- [] PZBK1	4.06 (103)	12
3400/3500-150	3150- [] PZ	3150- [] PZB	3150- [] PZBK1	5.04 (128)	15
3400/3500-175	3175- [] PZ	3175- [] PZB	3175- [] PZBK1	6.02 (153)	17
3400/3500-200	3200- [] PZ	3200- [] PZB	3200- [] PZBK1	7.01 (178)	20
3400/3500-225	3225- [] PZ	3225- [] PZB	3225- [] PZBK1	7.99 (203)	22
3400/3500-250	3250- [] PZ	3250- [] PZB	3250- [] PZBK1	8.98 (228)	25

34 or 12

For pivoting brackets choose 34

For locking brackets choose 12

Example: 3075- 34 PZB

PDF: igus.com/e-chain-pdfs
Product information: igus.com/e-chains



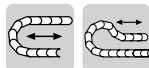

Option 1: pivoting

- For unsupported applications
- Bolted connection outside of chain cross section
- Confined installation conditions
- Attachment points on all sides
- Stackable

Moving end
34001...1

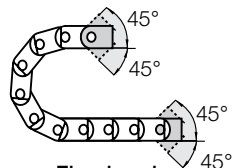

Fixed end
34001...2

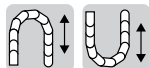

Option 2: locking

- For vertical hanging/standing applications
- Bolted connection outside of chain cross section
- For very high speeds and accelerations
- Attachment points on all sides
- Stackable

Moving end
34101...1

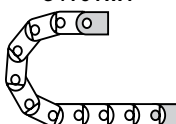

Fixed end
34101...2



Part Number Structure

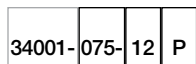

- With profile rail
- Complete Set
- Width
- Mounting brackets for selected chain type
34001 = Pivoting
34101 = Locking

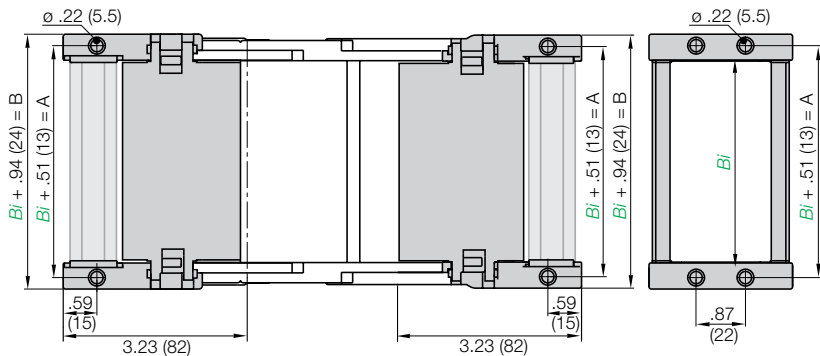

Full set, for both ends:

34001-12 P Full set, each part with pin/bore + profile rail

Single-part order:

34001-1 P Mounting bracket with bore + profile rail

34001-2 P Mounting bracket with pin + profile rail

Part No. Full Set (pivoting)

With Profile Rail

Series 3400/3500:

34001-Width-12P

Part No. Full Set (pivoting)

Without Profile Rail

Series 3400/3500:

34001-Width-12

For Chain Type	Part No. Full set with Profile Rail	Part No. Full Set without Profile Rail	Dimension A in. (mm)	Dimension B in. (mm)
3400/3500-050	34001-050-12P	34001-050-12	2.48 (63)	2.91 (74)
3400/3500-075	34001-075-12P	34001-075-12	3.46 (88)	3.90 (99)
3400/3500-100	34001-100-12P	34001-100-12	4.45 (113)	4.88 (124)
3400/3500-115	34001-115-12P	34001-115-12	5.04 (128)	5.47 (139)
3400/3500-150	34001-150-12P	34001-150-12	6.42 (163)	6.85 (174)
3400/3500-175	34001-175-12P	34001-175-12	7.40 (188)	7.83 (199)

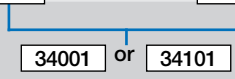

For pivoting brackets choose **34001**

For locking brackets choose **34101**

Example: **34001-075-12P**

e-chain system® E2/000

Series 3400/3500

Mounting Bracket - Steel



3400
3500

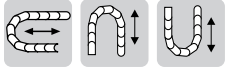

Option 1: Steel

- One part (two-piece) for all chain widths
- Electrically conductive
- Bolted connection outside of chain cross-section possible

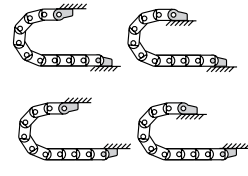
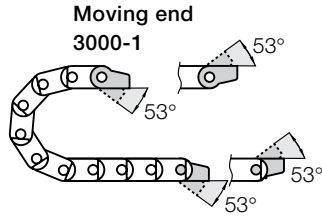

Possible installation configurations -

Fixed end
3000-2

3000-1

3000-2*

3000-1

3000-2

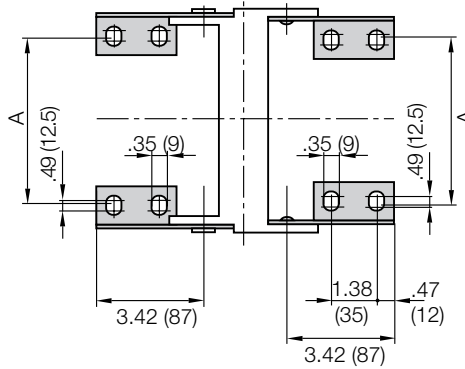
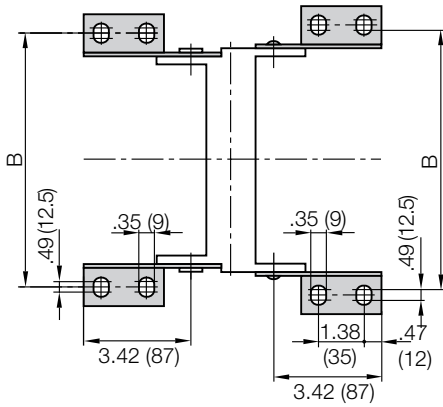

*pivoting with no stop, (360°)

Chain Type	Part No. Full Set	Dimension A		Dimension B	
		in.	(mm)	in.	(mm)
3400/3500-075	3000-12	2.09	(53)	4.37	(111)
3400/3500-100	3000-12	3.07	(78)	5.35	(136)
3400/3500-115	3000-12	3.66	(93)	5.94	(151)
3400/3500-150	3000-12	5.04	(128)	7.32	(186)
3400/3500-175	3000-12	6.02	(153)	8.35	(212)

Part No. Mounting Brackets Full Set

4 parts, 2 with pin, 2 with bore
Series 3400/3500:
3000-12

Part No. Mounting Bracket Moving End

2 parts, 1 left & 1 right
Series 3400/3500:
3000-1

Part No. Mounting Bracket Fixed End

2 parts, 1 left & 1 right
Series 3400/3500:
3000-2

PDF: igus.com/e-chain-pdfs
Product information: igus.com/e-chains



Chainfix clamps for the profile rail



igus® Chainfix strain relief elements are available in either steel or stainless steel. They can be adjusted with a hexagon socket and are available in single, double and triple configurations.

Part No. Single Clamp		Part No. Double Clamp		Part No. Triple Clamp		Cable ø	
Steel	Stainless	Steel	Stainless	Steel	Stainless	in.	(mm)
CFX12-1	CFX12-1E	CFX12-2	CFX12-2E	CFX12-3	-	.24 - .47	(06 - 12)
CFX14-1	CFX14-1E	CFX14-2	CFX14-2E	CFX14-3	-	.47 - .55	(12 - 14)
CFX16-1	CFX16-1E	CFX16-2	CFX16-2E	CFX16-3	-	.55 - .63	(14 - 16)
CFX18-1	CFX18-1E	CFX18-2	CFX18-2E	CFX18-3	-	.63 - .71	(16 - 18)
CFX20-1	CFX20-1E	CFX20-2	CFX20-2E	CFX20-3	-	.71 - .79	(18 - 20)
CFX22-1	CFX22-1E	CFX22-2	CFX22-2E	CFX22-3	-	.79 - .87	(20 - 22)
CFX26-1	CFX26-1E	CFX26-2	CFX26-2E	-	-	.87 - 1.02	(22 - 26)
CFX30-1	CFX30-1E	CFX30-2	CFX30-2E	-	-	1.02 - 1.18	(26 - 30)
CFX34-1	CFX34-1E	CFX34-2	CFX34-2E	-	-	1.18 - 1.34	(30 - 34)
CFX38-1	CFX38-1E	-	-	-	-	1.34 - 1.50	(34 - 38)
CFX42-1	CFX42-1E	-	-	-	-	1.50 - 1.65	(38 - 42)

For more information please refer to strain relief section of Chapter 10

Tiewrap Plates

**Option 1:
Tiewrap plates as an individual part**

Available as an individual component, can be fixed onto a mounting bracket with the use of a profile rail.

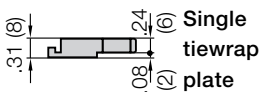
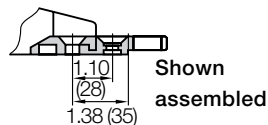

Tiewrap Plate	n Number of Teeth	C Overall Width in. (mm)	B Bore Width in. (mm)	Center Bore
3050-ZB	5	1.97 (50)	1.18 (30)	no
3075-ZB	7	2.95 (75)	2.16 (55)	no
3100-ZB	10	3.94 (100)	3.15 (80)	no
3115-ZB	11	4.53 (115)	3.74 (95)	no
3125-ZB	12	4.92 (125)	4.13 (105)	no
3150-ZB	15	5.91 (150)	5.12 (130)	no
3175-ZB	17	6.89 (175)	6.10 (155)	no
3200-ZB	20	7.87 (200)	7.09 (180)	yes
3225-ZB	22	8.86 (225)	8.07 (205)	yes
3250-ZB	25	9.84 (250)	9.06 (230)	yes

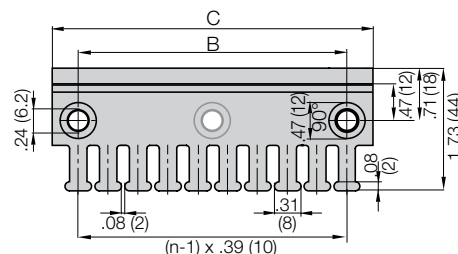

For more information please refer to strain relief section of Chapter 10

**Option 2:
Clip-on Tiewrap plates**

Available as a clip-on tiewrap plate without the use of bolts They are inserted and removed with a screwdriver used as a lever. Clip-on tiewrap plates are also available as an attachment to the opening crossbars.

Part No.	Number of Teeth	Width of Strain Relief in. (mm)
3050-ZC	5	1.97 (50)
3075-ZC	7	2.95 (75)

For more information please refer to strain relief section of Chapter 10

Strain relief for steel mounting brackets

Clip-on connection is not possible with steel mounting brackets. In this case, the tiewrap plates must be bolted directly into separate bore holes in front of the mounting bracket. Alternatively the tiewrap plates 30XX-Z and ZS can be also used here. **Details chapter 10**



e-chain[®] E2/000

Series 3400/3500

Guide Troughs



3400
3500

Guide troughs are used with applications where the upper run of the e-chain[®] glides on the lower run. If using igus[®] steel guide troughs, the following components are required:

- Full travel length of guide trough
Part Number 93-30
- 1/2 travel length of glide bars
Part number 93-01
- Installation sets as end connectors
Part Number 93-50 -XX

-XX indicates the length of the profile rail on which the guide trough is mounted. The values and part numbers are specified in the table on the left. The standard length of the trough components and glide bars is 6.56 ft (2 m.) The required overall length of the guide trough directly correlates to the length of travel.

Example:

Width of Crossbar
3500-075-200-0

	B_{Ri}	Installation Part No.
-050	2.95 (75)	93-50-200
-075	3.94 (100)	93-50-225
-100	4.92 (125)	93-50-250
-115	5.51 (140)	93-50-250
-125	5.91 (150)	93-50-275
-150	6.89 (175)	93-50-300
-175	7.87 (200)	93-50-325
-200	8.86 (225)	93-50-350
-225	9.84 (250)	93-50-375
-250	10.83 (275)	93-50-400

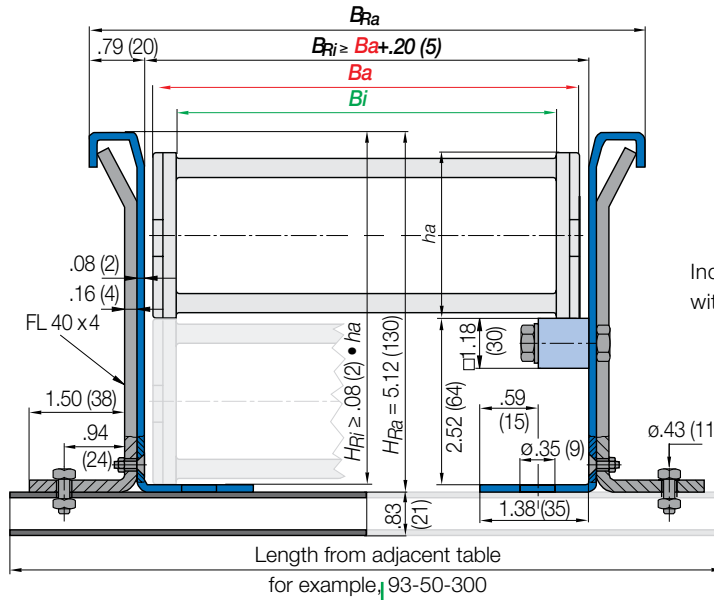

Length of travel 164 ft (50 m)

Center mounted

Required guide troughs:

164 ft (50 m) guide trough

82 ft (25 m) glide bar

= 25 sections of 6.56 ft (2 m) guide trough

Part No. 93-30

= 13 sections of 6.56 ft (2 m) glide bar

Part No. 93-01

Required number of installation sets:

= Number of guide trough components

+ 1

= 25 + 1 = 26

Part number of the installation sets

Example: 93-50-300 for 15.75" (400 mm) long profile rail.

- Guide trough
- Glide bars
- Installation set "Basic"
- Profile rail

Individual attachment without profile rail

* Specialized guide trough available upon request

PDF: igus.com/e-chain-pdfs
Product information: igus.com/e-chains

