

12 V - 0.6 A flyback isolated converter using VIPer™ Plus – VIPer0P

Data brief



Features

- Universal AC main input voltage range: 85 to 265 V_{AC}
- Output range: 12 V - 0.6 A
- Rated output power: 7.2 W
- Input power in standby @ 230 V_{AC}: less than 18 mW
- Active mode efficiency: > 80%
- EMI: according to EN55022-Class-B
- RoHS compliant

Description

The STEVAL-ISA180V1 evaluation board implements a wide mains range flyback isolated converter (12 V - 0.6 A), developed for general purpose applications.

This high-voltage converter intelligently integrates an 800 V rugged power MOSFET with PWM current-mode control. The core of the application is the new VIPer0P off-line high voltage converter from VIPerPlus family with zero power features.

The evaluation board features a small size and minimal BOM, high efficiency, low standby consumption and high reliability due to these protections: pulse skip mode to avoid flux-runaway, delayed overload protection (OLP), max duty cycle counter, V_{CC} clamp and thermal shutdown.

1 Schematic diagram

Figure 1: STEVAL-ISA180V1 circuit schematic

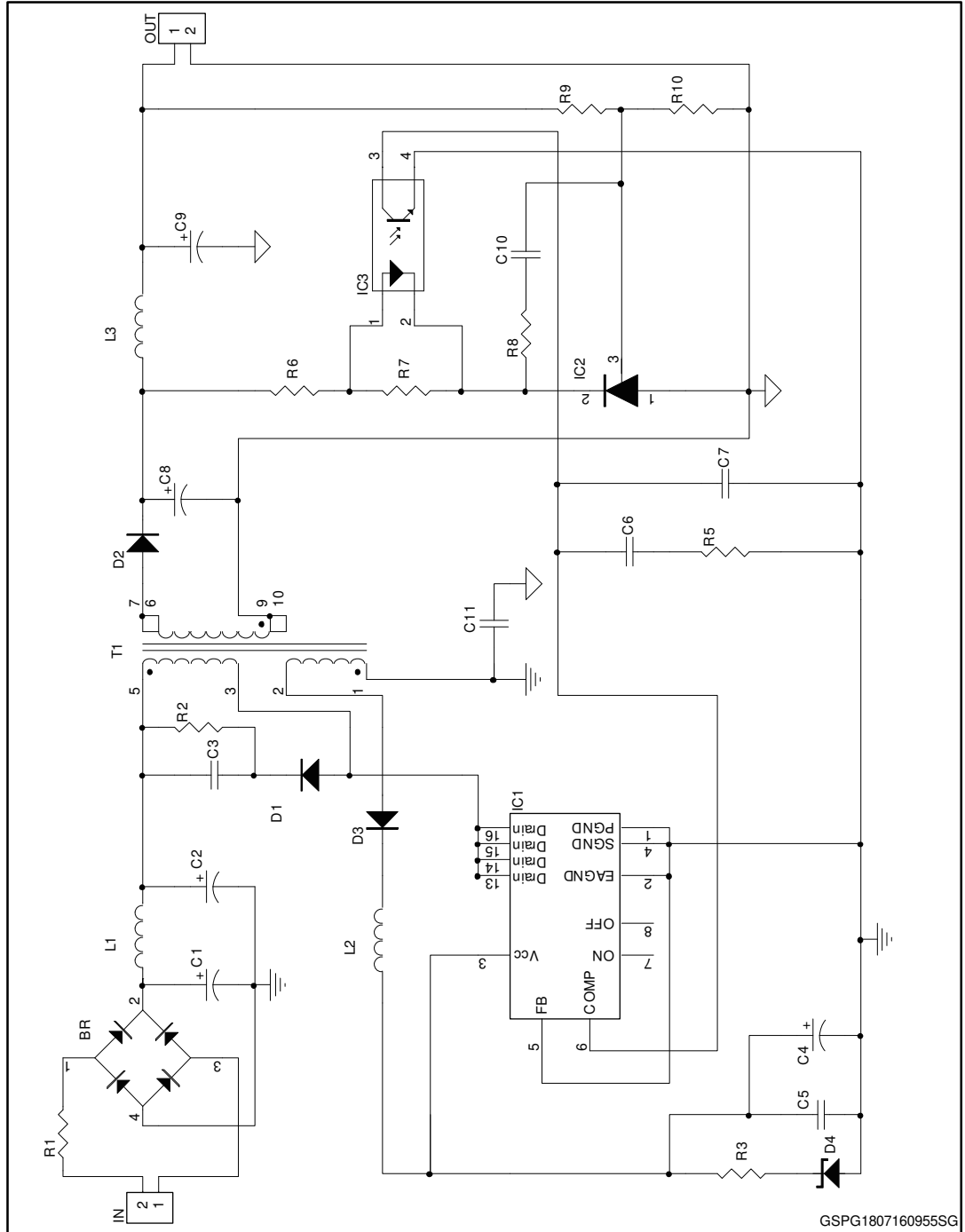

2 Revision history

Table 1: Document revision history

Date	Version	Changes
21-Jul-2016	1	Initial release.

IMPORTANT NOTICE – PLEASE READ CAREFULLY

STMicroelectronics NV and its subsidiaries ("ST") reserve the right to make changes, corrections, enhancements, modifications, and improvements to ST products and/or to this document at any time without notice. Purchasers should obtain the latest relevant information on ST products before placing orders. ST products are sold pursuant to ST's terms and conditions of sale in place at the time of order acknowledgement.

Purchasers are solely responsible for the choice, selection, and use of ST products and ST assumes no liability for application assistance or the design of Purchasers' products.

No license, express or implied, to any intellectual property right is granted by ST herein.

Resale of ST products with provisions different from the information set forth herein shall void any warranty granted by ST for such product.

ST and the ST logo are trademarks of ST. All other product or service names are the property of their respective owners.

Information in this document supersedes and replaces information previously supplied in any prior versions of this document.

© 2016 STMicroelectronics – All rights reserved