

DATE	REV.	ECN	APP'D BY
1-2-20	X0	-	ADB
3-31-20	A0	-	JE
5-15-20	A1	11552	JE

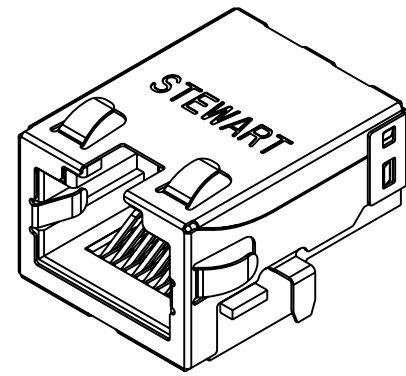

ISOMETRIC VIEW

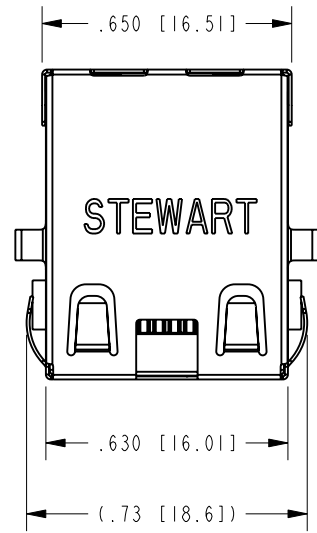
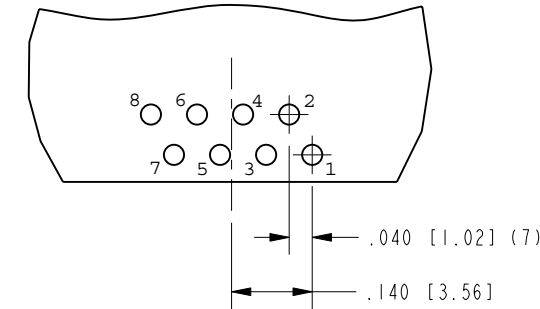

DETAIL A
SCALE 3.000

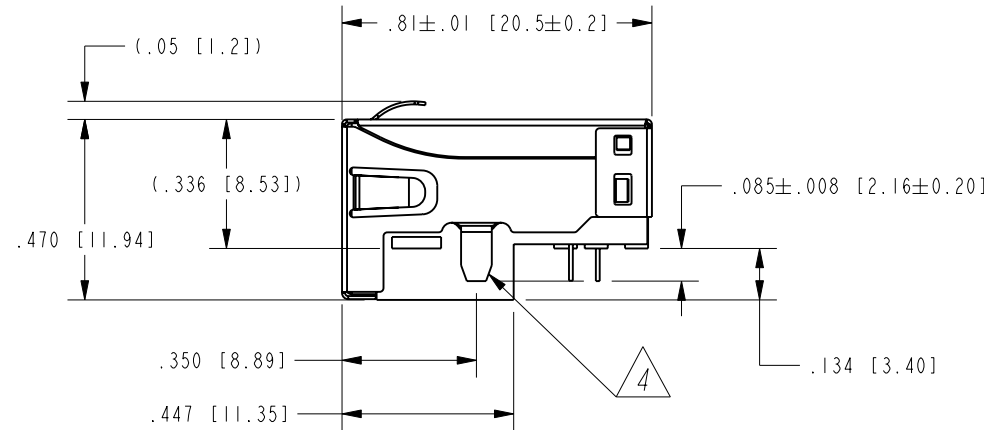
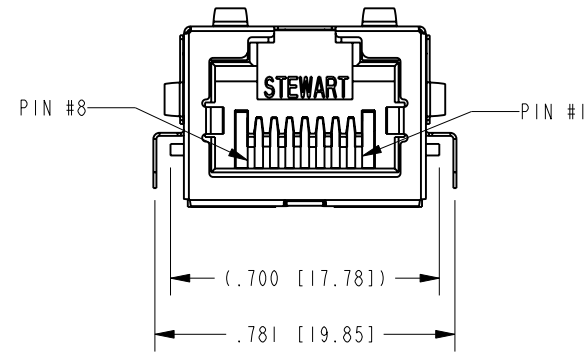

NOTES:

- CONNECTOR MATERIALS:
HOUSING: HALOGEN FREE THERMOPLASTIC UL94 V-0
CONTACTS: COPPER ALLOY
SHIELD: STAINLESS STEEL
CONTACT PLATING: SELECTIVE GOLD IN CONTACT AREA (SEE CHART FOR PART NUMBER)
MATTE TIN PLATED SOLDER TAILS
- FOR PRODUCT SPECIFICATIONS SEE PR022-01.
- DIMENSIONS AND TOLERANCES COMPLY WITH TIA-1096 STANDARD.
- SHIELD LEADS (2) ARE TIN DIPPED TO .010 MIN ABOVE TOP SURFACE OF PRINTED CIRCUIT BOARD SEATING PLANE.
- DESIGNED FOR CATEGORY 5/5E APPLICATIONS.

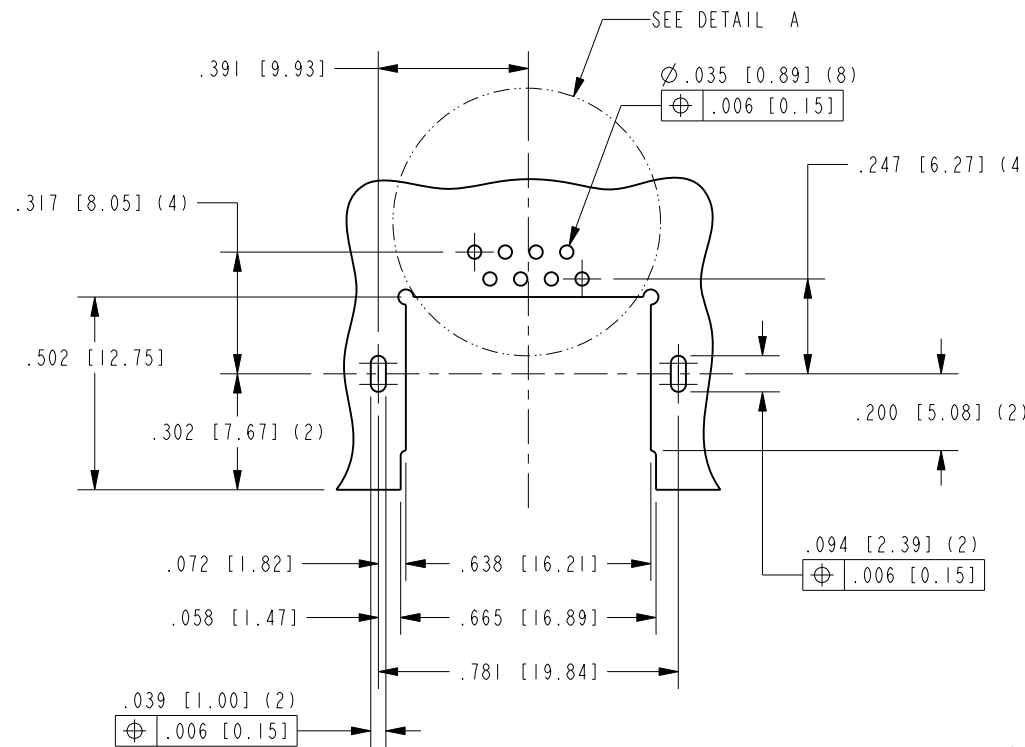
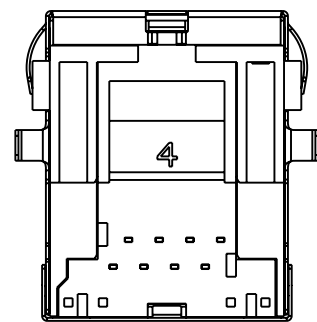

P.C.B. RECOMMENDED HOLE LAYOUT
SEEN FROM COMPONENT SIDE
ALL CENTERLINE DIMENSIONS ARE BASIC

RoHS



50 MICRO-INCHES [1.27um]	SS-74800-143
CONTACT PLATING IN MATING AREA	PART NUMBER

THIRD ANGLE PROJECTION

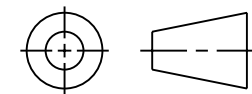

11118 Susquehanna Trail South
Glen Rock, PA 17327-9199
(717) 235-7512
<http://www.stewartconnector.com>

DO NOT SCALE DRAWING
DRAWING IS SUBJECT TO
CHANGE WITHOUT NOTICE

TITLE: RJ45 SINGLE PORT MIDPLANE JACK
WITHOUT LEDS, HALOGEN FREE MATERIAL

DIMENSIONS: INCHES [METRIC]
UNLESS OTHERWISE SPECIFIED
TOLERANCES ARE ±.005 [0.13]
ANGLES ARE ±1°

THIS DRAWING AND THE SUBJECT MATTER SHOWN THEREON
ARE CONFIDENTIAL AND THE PROPRIETARY PROPERTY OF
STEWART CONNECTOR AND SHALL NOT BE REPRODUCED,
COPIED, OR USED IN ANY MANNER WITHOUT PRIOR WRITTEN
CONSENT OF STEWART CONNECTOR. ONE OR MORE U.S. PATENTS
MAY APPLY TO THIS PRODUCT. FOR DETAILS, PLEASE
VISIT: [HTTP://BELFUSE.COM/STEWART/STEWART_PATENTS/](http://BELFUSE.COM/STEWART/STEWART_PATENTS/)

DRN BY:	JE	DATE	12-20-19
APPD BY:	ADB	DATE	1-2-20
DWG. NO.	CT740270	REV.	A1

SHEET NO.
1 OF 1

B

B

A

A