

THIS DRAWING IS UNPUBLISHED. RELEASED FOR PUBLICATION 20  
 © COPYRIGHT 20 BY - ALL RIGHTS RESERVED.

ITEM	DESCRIPTION	MATERIAL	OTHERS
1	MALE CONTACT	COPPER ALLOY	GOLD PLATED
2	HOUSING	NYLON	BLACK
3	COUPLING NUT	COPPER ALLOY	NICKEL PLATED
4	OVER-MOLDING	TPU	BLACK
5	SHIELDED SHELL	COPPER ALLOY	NICKEL PLATED
6	CABLE	PUR	VIOLET
7	LABEL	-	-

REVISIONS				
P	LTR	DESCRIPTION	DATE	APVD
	A	INITIAL RELEASE	08JUN2021	BP CW

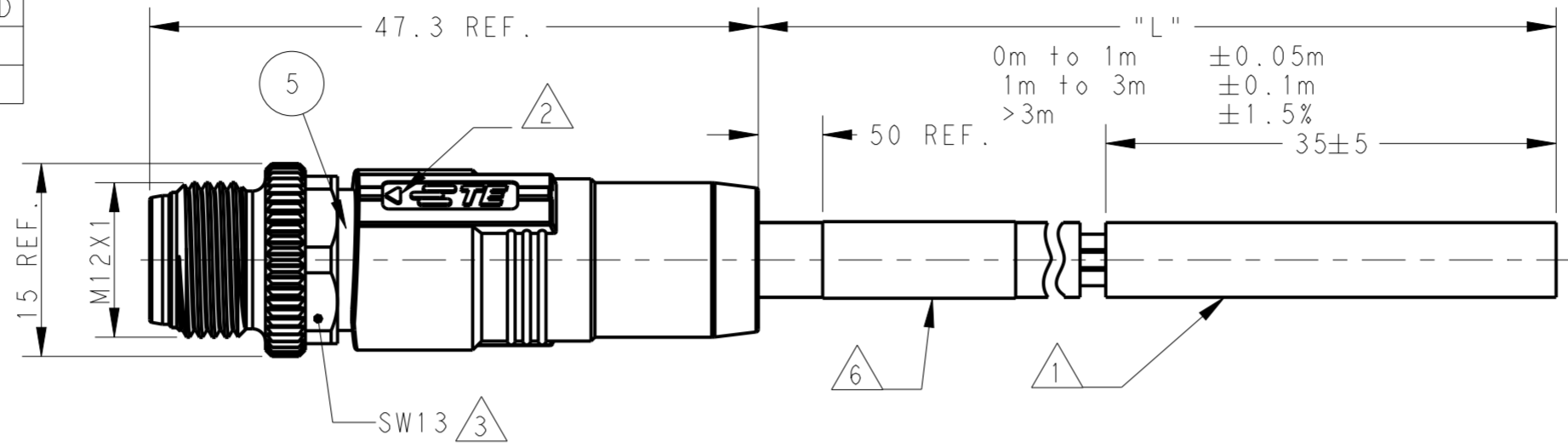
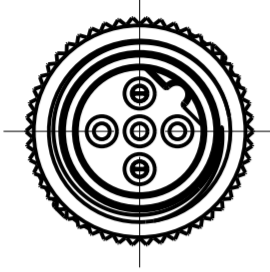

NOTE:  
 ①. STRIP AND RETAIN THE INSULATION  
 ②. CODE POSITION INDICATOR  
 ③. RECOMMENDED TORQUE 0.6 Nm  
 ④. -\*\* : CABLE LENGTH, FOR EXAMPLE: -0.5M  
 ⑤. CABLE ASSEMBLY TO BE PACKAGED IN POLYBAGS  
 ⑥. LABEL CONTAINS: PN, DATE CODE...

注释:  
 ①. 剥线并保留护套绝缘层  
 ②. CODE位置指示  
 ③. 推荐扭矩0.6 Nm  
 ④. -\*\* : 线缆长度, 例如: -0.5M  
 ⑤. 线缆组件塑料袋包装  
 ⑥. 标签包含: 产品编号, 日期代码...

TE PN CODING:

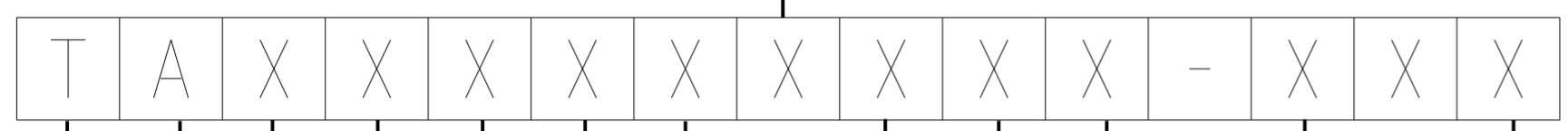

CABLE JACKET  
 5=PUR HIGH FLEXIBLE(DRAG CHAIN)  
 6=PUR HIGH FLEXIBLE(TORSION)

TYPICAL LENGTH:  
 -001:0.5M  
 -002:1.0M  
 -020:2.0M  
 -040:4.0M  
 -060:6.0M  
 -080:8.0M  
 -007:10.0M  
 -150:15.0M  
 CUSTOMIZATION RULES:  
 -003:1.5M  
 -004:3.0M  
 -005:5.0M  
 -006:7.0M  
 -99X:0.XM(<1.0M)  
 (-993:0.3M)  
 -XXX:XX.XM(>1.0M)  
 (-155:15.5M)

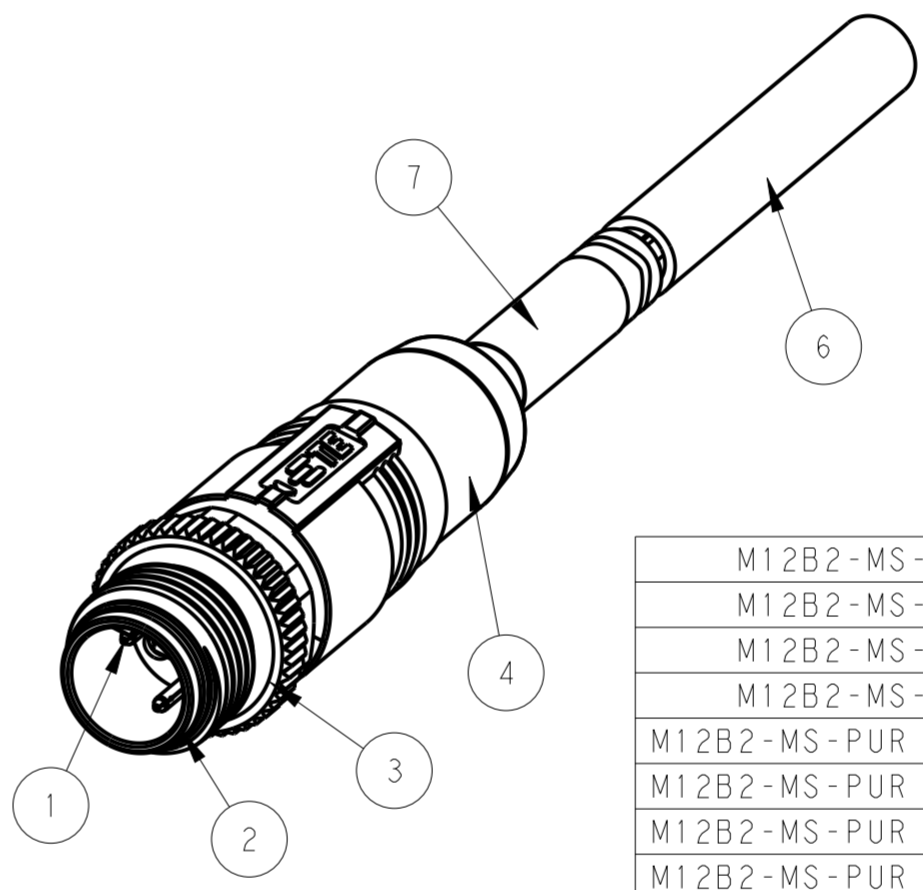

DESCRIPTION	TE PN	ENTRELEC PN
M12B2-MS-PUR-0.5M	TAB62135501-001	1SET315174R0000
M12B2-MS-PUR-1.0M	TAB62135501-002	1SET315175R0000
M12B2-MS-PUR-2.0M	TAB62135501-020	1SET315177R0000
M12B2-MS-PUR-4.0M	TAB62135501-040	1SET315178R0000
M12B2-MS-PUR TORSION-0.5M	TAB62146501-001	1SET315182R0000
M12B2-MS-PUR TORSION-1.0M	TAB62146501-002	1SET315183R0000
M12B2-MS-PUR TORSION-2.0M	TAB62146501-020	1SET315185R0000
M12B2-MS-PUR TORSION-4.0M	TAB62146501-040	1SET315186R0000

INTERFACE TYPE  
 1=MALE STRAIGHT  
 2=MALE ANGLED  
 3=FEMALE STRAIGHT  
 4=FEMALE ANGLED  
 5=MALE STRAIGHT TO FEMALE STRAIGHT  
 6=MALE STRAIGHT TO FEMALE ANGLED  
 A=MALE ANGLED TO FEMALE STRAIGHT

OTHER ATTRIBUTES  
 1-STANDARD SCREW NUT WITH NICKEL PLATED/  
 STAMPED TERMINAL 30U"AU PLATING

WIRES:22AWG  
 WIRE COLOR: RED AND GREEN  
 OD: APPROX.8.0MM  
 TEMPERATURE RATING:80°C UL  
 OPERATION TEMP RATING:-25°C To +75°C  
 APPLICATIONS:FLEXIBLE,SUITABLE FOR ±180°  
 TORSION APPLICATION,5 MILLION CYCLES  
 FOR 1M LENGTH

WIRES:24AWG  
 WIRE COLOR: RED AND GREEN  
 OD: APPROX.7.8MM  
 TEMPERATURE RATING:80°C UL  
 OPERATION TEMP RATING:  
 -40°C To +80°C  
 APPLICATIONS:  
 FLEXIBLE,SUITABLE FOR DRAG CHAIN,  
 MIN. 1 MILLION CYCLES,DIAMETER 75MM,  
 SPEED 2m/s,ACCELERATION 2m/s²

CABLE CHARACTERISTIC	LENGTH "L"	JACKET COLOR	JACKET MATERIAL	TYPE	POS.	TE PN
		VIOLET	PUR	M12B2-MS-PUR TORSION-**④	2	TAB62146501-XXX
				M12B2-MS-PUR-**④		TAB62135501-XXX

PIN ARRANGEMENT B-CODE

PIN 2 DATE CORE A	GREEN
PIN 4 DATE CORE B	RED

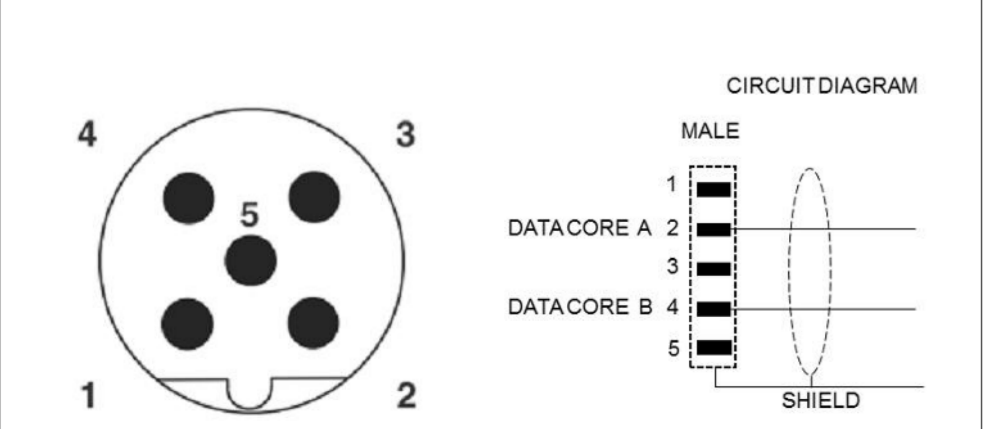

TECHNICAL DATA	
RATED VOLTAGE	250V
RATED IMPULSE VOLTAGE	2500V
RATED CURRENT	4A
POLLUTION DEGREE	3
OVERVOLTAGE CATEGORY	II
MATERIAL GROUP	II
DEGREE OF PROTECTION	IP67

THIS DRAWING IS A CONTROLLED DOCUMENT.

DWN	08JUN2021	BLAZE PENG
CHK	08JUN2021	KEVIN HUANG
APVD	08JUN2021	CHRIS WANG

ENTRELEC Electrical Solutions

NAME: M12 B CODE CABLE ASSY, SHIELDED 2P, MS FREE END

PRODUCT SPEC: 108-106140  
 APPLICATION SPEC: 114-137144

SIZE: A2 CAGE CODE: - DRAWING NO: ©-1SET311A06R0000 RESTRICTED TO: A

RESTRICTED CUSTOMER SCALE: 2:1 SHEET 1 OF 1 REV A