

used for: D-SUB

POS.	A ^{-0.76}	B ^{-0.25}	C	Part NO.
9	31.19	16.46	25.00 ^{+0.12} / _{-0.13}	164A16569X
15	39.52	24.79	33.30 ^{+0.15} / _{-0.1}	164A16579X
25	53.42	38.50	47.04 ^{+0.13}	164A16589X
37	69.70	54.96	63.50 ^{+0.13}	164A16599X

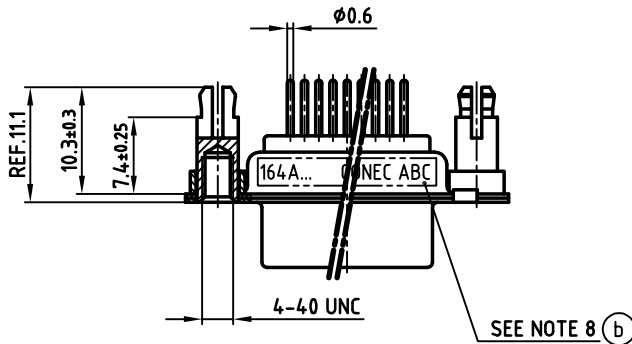
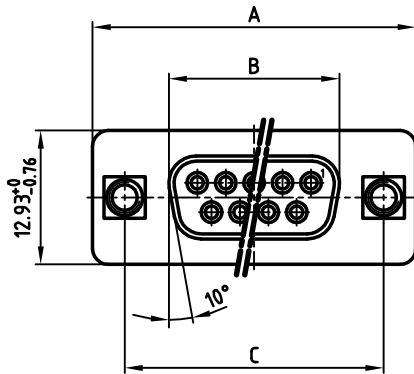
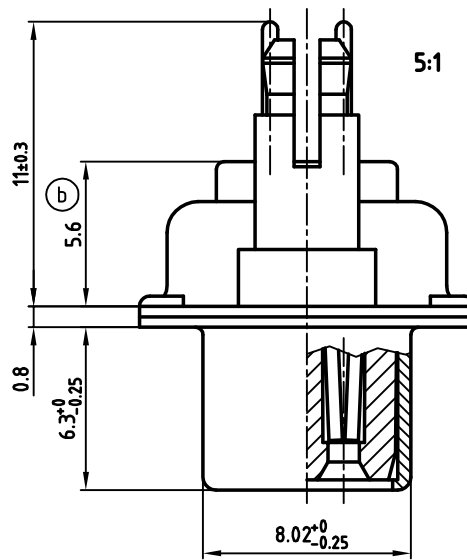

(b) NOTES:

- METALSHELLS: STEEL; min. 315µm TIN over 40-80µm NICKEL
- INSULATORS: PBT GF UL 94 V-0, BLACK
- CONTACTS: COPPER ALLOY
PLATING: 8µm HARD GOLD over min. 50µm NICKEL
- THREADED SPACER CLIP: COPPER ALLOY; min. 200µm TIN over 80µm NICKEL
PCB-HOLE: $\varnothing 3.1 \pm 0.1$; PCB THICKNESS 1.6mm
- COLLAR: COPPER ALLOY; min. 200µm TIN over 80µm NICKEL
- P.C.B. HOLE DRILLINGS ON DRAWING NO.: 16K111UA
- MAXIMUM TORQUE VALUE FOR THREAD: 6in.LB
- CONNECTOR IS PART MARKED: PART-NO. CONEC ABC



APPROVAL # FREIGABE # DEBLOCAGE # AUTORIZACION # APPROVAL	
CUSTOMER APPROVAL DATE:	
NAME:	TITLE:
COMPANY NAME:	
APPROVAL # FREIGABE # DEBLOCAGE # AUTORIZACION # APPROVAL	

THIS DRAWING MAY NOT BE COPIED OR REPRODUCED IN ANY WAY, AND MAY NOT BE PASSED ON TO A THIRD PARTY, WITHOUT WRITTEN PERMISSION.
OWNERSHIP AND COPYRIGHT OF CONEC GmbH
DO NOT ALTER CAD DRAWING BY HAND

rev.	description	date	name
3 x b	Ä3304	03.03.09	Petker
a	Origin		

tolerance		scale:	2:1 (5:1)
	dim. in mm	material:	SEE NOTES
2000	date	name	title:
drawn	20.11.	Parei	D-SUB FEMALE
appd.	20.11.	Schrader	9-37pos. PIN VERSION
norm	DIN 41652		with threaded spacer clip
d-old			dwg no: AutoCAD 2000 DIN-A
			16K1A370A
			3 sh: 1/1
			part no: SEE TABLE

APPROVAL # FREIGABE # DEBLOCAGE # AUTORIZACION # APPROVAL	
CUSTOMER APPROVAL DATE:	
NAME:	TITLE:
COMPANY NAME:	
APPROVAL # FREIGABE # DEBLOCAGE # AUTORIZACION # APPROVAL	