

Features

- Super Regenerative Radio Receiver
- CMOS / TTL Output
- Stable Operating Frequency
- Low Current Consumption
- 5Vdc Operating Voltage
- ASK Demodulation
- Available as 315 or 433 MHz

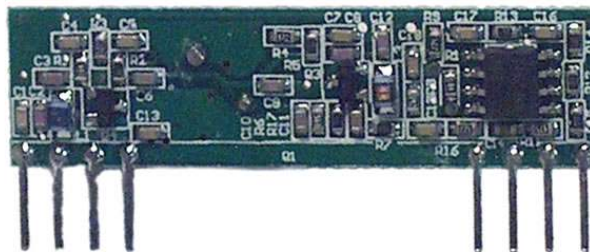

Applications

- Wireless Security Systems
- Garage Door controller
- Remote Gate Controls
- Remote Sensing
- Data Capture
- Sensor Reporting

Description

The Quasar UK AM hybrid receiver module provides a complete Radio receiver which can be used to receive undecoded data from the range of Quasar (UK) transmitter modules.

The module is very simple to operate and offers a low current consumption, allowing for extended battery life when used in mobile applications.

Data can be fed directly into a microprocessor or decoding device, thus keeping the component count down and ensuring a low hardware cost.

All receivers are compatible, producing a CMOS/TTL output, and only require connections to power and antenna.

Part Numbers

Part Number	Description
QAM-RX2-433	AM Super Regen Receiver Module, 433MHz
QAM-RX2-315	AM Super Regen Receiver Module, 315MHz

Technical Specifications

Pin Descriptions

Pin	Description
1	External Antenna
2, 3, 8	Ground
6, 7	Data input
4,5	Supply Voltage

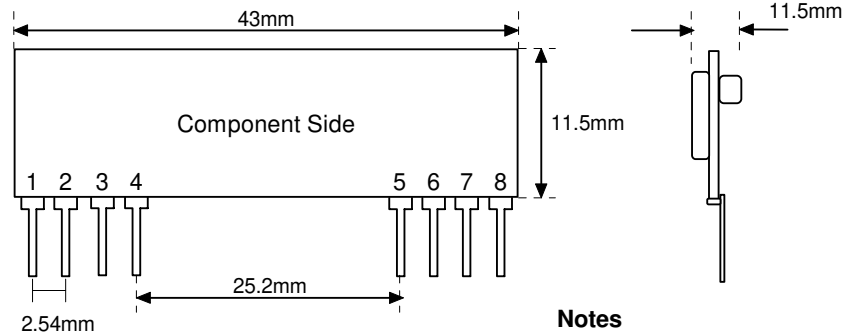

Notes

Pins on 0.1" pitch
Pin Dims :0.25 x 0.50mm

Electrical Characteristics

Ambient temp = 25°C unless otherwise stated.

Characteristic	Min.	Typ.	Max.	Dimensions
Supply Voltage		5		Vdc
Supply Current	3	3.5	4.5	mA
RF Sensitivity		-105		dBm
Working Frequency		315 / 433.92		MHz
High Level Output	0.7Vcc			VDC
Low Level Output			0.3Vcc	VDC
Turn On Time		25		Ms
Data Rate	200		3,000	Hz
Operating Temperature	-10		+60	°C

Typical Application

For further information on this circuit please refer to the RF Solutions datasheet DS600

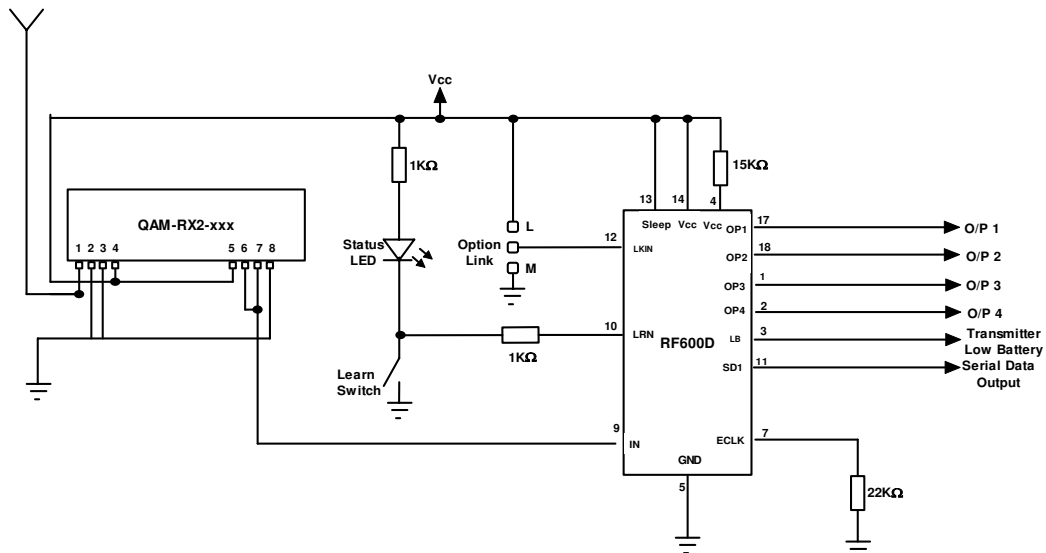

www.quasaruk.co.uk

Information contained in this document is believed to be accurate, however no representation or warranty is given and no liability is assumed by Quasar (UK) Ltd. with respect to the accuracy of such information. Use of products as critical components in life support systems is not authorised except with express written approval from Quasar (UK) Ltd.