

Single Cell Li-Ion/Li-Polymer Battery Manager With Impedance Track Fuel Gauge Technology

Check for Samples: [bq27350](#)

1 INTRODUCTION

1.1 FEATURES

- **Comprehensive Battery Fuel Gauge for Single Cell and 1-Series Li-Ion/Li-Polymer Applications**
- **Secure Battery Authentication Using SHA-1/HMAC Encryption**
- **Calculates and Reports**
 - Remaining Battery Capacity
 - Battery Voltage and Temperature
 - Charge and Discharge Current
 - Four Time-to-Empty Predictions
- **Battery Fuel Gauge Based on Patented Impedance Track™ Technology**
 - Models the Battery Discharge Curve for Accurate Time-to-Empty Predictions
 - Automatically Adjusts for Battery Aging, Battery Self Discharge, and Temperature/Rate Inefficiencies
 - Low Value Sense Resistor (10mΩ or Less)
- **96-Bytes Non-Volatile Scratch Pad Data Memory**
- **I²C Communications Interface to the Host**
- **20-Pin TSSOP Package**

1.2 APPLICATIONS

- POS Terminals
- Industrial Data Collection

- Smartphones
- PDAs
- Digital Cameras
- Handheld Terminals

1.3 DESCRIPTION

The Texas Instruments' bq27350 is a battery fuel gauge with secure authentication support for single cell Li-Ion/Li-Polymer battery packs. Designed for battery pack integration, the device requires little host microcontroller firmware support for implementation. The system host processor communicates with the bq27350 over an I²C interface to obtain remaining battery capacity, system run-time predictions, and other critical battery information.

The bq27350 uses the patented Impedance Track™ algorithm for its fuel gauging. The gauge provides information such as state-of-charge (%), run-time to empty (min.), charge time to full (min.), battery voltage (V), and pack temperature (°C).

The bq27350 also features both integrated and external support for secure battery pack authentication, using the SHA-1/HMAC authentication algorithm.

TYPICAL IMPLEMENTATION

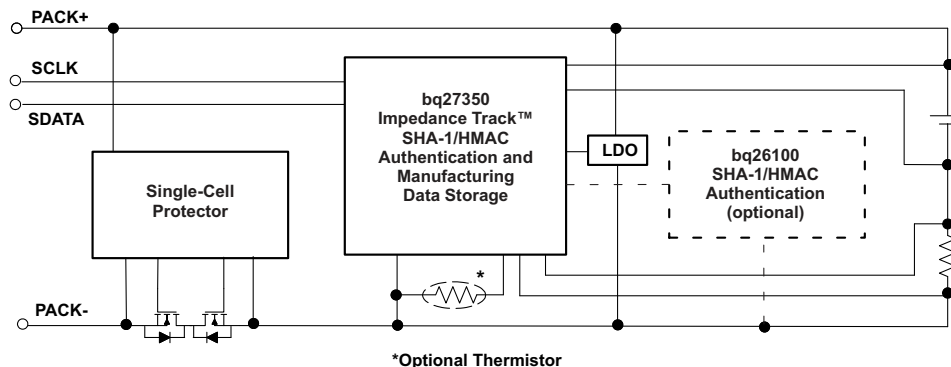

Please be aware that an important notice concerning availability, standard warranty, and use in critical applications of Texas Instruments semiconductor products and disclaimers thereto appears at the end of this data sheet.

Impedance Track is a trademark of Texas Instruments.

1	INTRODUCTION	1	4.1	DATA COMMANDS	8
1.1	FEATURES	1	4.2	EXTENDED DATA COMMANDS	14
1.2	APPLICATIONS	1	4.3	DATA FLASH INTERFACE	16
1.3	DESCRIPTION	1	4.4	MANUFACTURER INFORMATION BLOCKS	16
2	DEVICE INFORMATION	3	4.5	ACCESS MODES	17
2.1	AVAILABLE OPTIONS	3	4.6	SEALING/UNSEALING DATA FLASH ACCESS	17
2.2	PIN DIAGRAM	3			17
2.3	TERMINAL FUNCTIONS	3	4.7	DATA FLASH SUMMARY	17
3	ELECTRICAL SPECIFICATIONS	4	5	FUNCTIONAL DESCRIPTION	19
3.1	ABSOLUTE MAXIMUM RATINGS	4	5.1	FUEL GAUGING	19
3.2	RECOMMENDED OPERATING CONDITIONS	4	5.2	IMPEDANCE TRACK VARIABLES	20
3.3	POWER-ON RESET	4	5.3	TEMPERATURE MEASUREMENT	22
3.4	TEMPERATURE SENSOR CHARACTERISTICS	4	5.4	OVER-TEMPERATURE INDICATION	22
3.5	LOW FREQUENCY OSCILLATOR	5	5.5	CHARGING AND CHARGE TERMINATION	22
3.6	HIGH FREQUENCY OSCILLATOR	5		INDICATION	22
3.7	INTEGRATING ADC (COULOMB COUNTER)	5	5.6	POWER MODES	22
3.8	ADC (TEMPERATURE AND CELL VOLTAGE)	5	5.7	POWER CONTROL	24
3.9	I ² C-COMPATIBLE INTERFACE TIMING	5	5.8	AUTOCALIBRATION	26
4	GENERAL DESCRIPTION	7	6	COMMUNICATIONS	26
			6.1	I ² C INTERFACE	26
			6.2	AUTHENTICATION	27
			7	REFERENCE SCHEMATIC	28
				REVISION HISTORY	29

2 DEVICE INFORMATION

2.1 AVAILABLE OPTIONS

T_A	PACKAGE TSSOP (PW) ⁽¹⁾
–40°C to 85°C	bq27350PW

(1) For the most current package and ordering information, see the Package Option Addendum at the end of this document, or see the TI website at www.ti.com.

2.2 PIN DIAGRAM

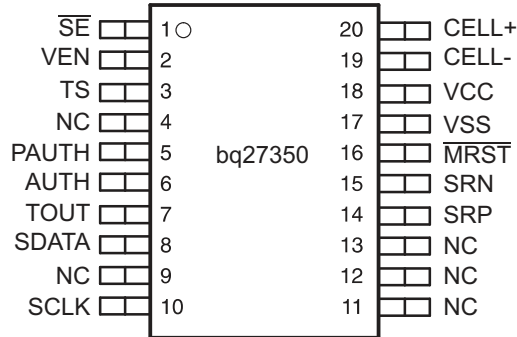

2.3 TERMINAL FUNCTIONS

TERMINAL		I/O ⁽¹⁾	DESCRIPTION
NAME	NO.		
\overline{SE}	1	I/O	System enable. Open-drain output for controlling LDO enable (active low).
VEN	2	O	Voltage divider enable
TS	3	IA	Thermistor measurement input if external thermistor selected
PAUTH	5	P	Positive supply line for powering optional bq26100
AUTH	6	IO	Signal line for communicating with optional bq26100
TOUT	7	OA	Thermistor power output
SDATA	8	I/O	I ² C Interface bidirectional data line (open-drain)
SCLK	10	I/O	I ² C Interface clock line (open-drain)
SRP	14	IA	Analog input pin connected to the internal coulomb-counter where SRP is connected to the CELL- side of the sense resistor
SRN	15	IA	Analog input pin connected to the internal coulomb-counter where SRN is connected to the side of the sense resistor nearest PACK-
\overline{MRST}	16	I	Master reset of the bq27350
VSS	17	P	Power ground of the IC
VCC	18	P	Power supply of the IC
CELL-	19	IA	Negative node of differential cell measurement Input
CELL+	20	IA	Positive node of differential cell measurement Input
NC	4, 9, 11, 12, 13	NA	Pins electrically connected internally, and should be left floating for normal operation.

(1) I/O = Digital Input/Output, IA = Analog Input, OA = Analog Output, P = Power Connection

3 ELECTRICAL SPECIFICATIONS

3.1 ABSOLUTE MAXIMUM RATINGS

over operating free-air temperature range (unless otherwise noted)⁽¹⁾

PARAMETER	VALUE	UNIT
V _{CC} Supply voltage range	–0.3 to 2.75	V
V _(IOD) Open-drain I/O pins	–0.3 to 6	V
V _I Input voltage range to all other pins	–0.3 to V _{CC} + 0.3	V
T _A Operating free-air temperature range	–40 to 85	°C
T _{stg} Storage temperature range	–65 to 150	°C

(1) Stresses beyond those listed under absolute maximum ratings may cause permanent damage to the device. These are stress ratings only, and functional operation of the device at these or any other conditions beyond those indicated under recommended operating conditions is not implied. Exposure to absolute-maximum-rated conditions for extended periods may affect device reliability.

3.2 RECOMMENDED OPERATING CONDITIONS

T_A = 25°C, V_{CC} = 2.5 V (unless otherwise noted)

PARAMETER	TEST CONDITIONS	MIN	TYP	MAX	UNIT
V _{CC} Supply Voltage		2.4	2.5	2.6	V
I _{CC} Normal operating mode current ⁽¹⁾	No flash programming		150		μA
I _(SLP) Low-power storage mode current ⁽²⁾	Sleep mode		7.4		μA
I _(HIBERNATE) Hibernate operating mode current ⁽³⁾	Hibernate mode		1.5		μA
V _{OL} Output voltage low (SDA, VEN)	I _{OL} = 0.5 mA			0.4	V
V _{OH} Output high voltage (SDA)	I _{OH} = –1 mA	V _{CC} –0.5			V
V _{IL} Input voltage low (SDA, SCL)		–0.3		0.8	V
V _{IH} Input voltage high (SDA, SCL)		2		6	V
C _{IN} Input capacitance				5	pF
V _(AI1) Input voltage range (CELL+, CELL–, TS)		V _{SS} –0.3		1	V
V _(AI2) Input voltage range (SRP, SRN)		V _{SS} –0.20		0.20	V

(1) Load current > sleep current threshold during half of operation. Load current < sleep current threshold during other half.

(2) Low-frequency oscillator, I/O support, and IWAKE comparator circuits on.

(3) I/O support and IWAKE comparator circuits on.

3.3 POWER-ON RESET

T_A = –40°C to 85°C, 2.4 V < V_{CC} < 2.6 V; Typical Values at T_A = 25°C and V_{CC} = 2.5 V (unless otherwise noted)

PARAMETER	TEST CONDITIONS	MIN	TYP	MAX	UNIT
V _{IT–} Negative-going input voltage (V _{CC})		1.7	1.8	1.9	V
V _{HYS} Power-on reset hysteresis		50	125	200	mV

3.4 TEMPERATURE SENSOR CHARACTERISTICS

T_A = –40°C to 85°C, 2.4 V < V_{CC} < 2.6 V; Typical Values at T_A = 25°C and V_{CC} = 2.5 V (unless otherwise noted)

PARAMETER	TEST CONDITIONS	MIN	TYP	MAX	UNIT
G _{TEMP} Temperature sensor voltage gain			–2.0		mV/°C

3.5 LOW FREQUENCY OSCILLATOR

$T_A = -40^{\circ}\text{C}$ to 85°C , $2.4\text{ V} < V_{CC} < 2.6\text{ V}$; Typical Values at $T_A = 25^{\circ}\text{C}$ and $V_{CC} = 2.5\text{ V}$ (unless otherwise noted)

PARAMETER	TEST CONDITIONS	MIN	TYP	MAX	UNIT
$f_{(\text{LOSC})}$ Operating frequency			32.768		kHz
$f_{(\text{LEIO})}$ Frequency error ^{(1) (2)}	$T_A = 0^{\circ}\text{C}$ to 60°C	-1.5%	0.25%	1.5%	
	$T_A = -20^{\circ}\text{C}$ to 70°C	-2.5%	0.25%	2.5%	
	$T_A = -40^{\circ}\text{C}$ to 85°C	-4.0%	0.25%	4.0%	
$t_{(\text{LSXO})}$ Start-up time ⁽³⁾				500	μs

(1) The frequency drift is included and measured from the trimmed frequency at $V_{CC} = 2.5\text{V}$, $T_A = 25^{\circ}\text{C}$.

(2) The frequency error is measured from 32.768 kHz.

(3) The startup time is defined as the time it takes for the oscillator output frequency to be $\pm 3\%$.

3.6 HIGH FREQUENCY OSCILLATOR

$T_A = -40^{\circ}\text{C}$ to 85°C , $2.4\text{ V} < V_{CC} < 2.6\text{ V}$; Typical Values at $T_A = 25^{\circ}\text{C}$ and $V_{CC} = 2.5\text{ V}$ (unless otherwise noted)

PARAMETER	TEST CONDITIONS	MIN	TYP	MAX	UNIT
$f_{(\text{OSC})}$ Operating frequency			4.194		MHz
$f_{(\text{EIO})}$ Frequency error ^{(1) (2)}	$T_A = 0^{\circ}\text{C}$ to 60°C	-2.0%	0.25%	2.0%	
	$T_A = -20^{\circ}\text{C}$ to 70°C	-3.0%	0.25%	3.0%	
	$T_A = -40^{\circ}\text{C}$ to 85°C	-4.5%	0.25%	4.5%	
$t_{(\text{SXO})}$ Start-up time ⁽³⁾			2.5	5	ms

(1) The frequency error is measured from 4.194 MHz.

(2) The frequency drift is included and measured from the trimmed frequency at $V_{CC} = 2.5\text{V}$, $T_A = 25^{\circ}\text{C}$.

(3) The startup time is defined as the time it takes for the oscillator output frequency to be $\pm 3\%$.

3.7 INTEGRATING ADC (COULOMB COUNTER) CHARACTERISTICS

$T_A = -40^{\circ}\text{C}$ to 85°C , $2.4\text{ V} < V_{CC} < 2.6\text{ V}$; Typical Values at $T_A = 25^{\circ}\text{C}$ and $V_{CC} = 2.5\text{ V}$ (unless otherwise noted)

PARAMETER	TEST CONDITIONS	MIN	TYP	MAX	UNIT
$V_{(\text{SR})}$ Input voltage range, $V_{(\text{SRN})}$ and $V_{(\text{SRP})}$	$V_{(\text{SR})} = V_{(\text{SRN})} - V_{(\text{SRP})}$	-0.20		0.20	V
Resolution			16		bits
$V_{(\text{SROS})}$ Input offset	After Auto-Calibration		10		μV
INL Integral nonlinearity error			± 0.007	± 0.034	% FSR
$Z_{\text{ADC_IN}}$ Effective input resistance		2.5			$\text{M}\Omega$

3.8 ADC (TEMPERATURE AND CELL VOLTAGE) CHARACTERISTICS

$T_A = -40^{\circ}\text{C}$ to 85°C , $2.4\text{ V} < V_{CC} < 2.6\text{ V}$; Typical Values at $T_A = 25^{\circ}\text{C}$ and $V_{CC} = 2.5\text{ V}$ (unless otherwise noted)

PARAMETER	TEST CONDITIONS	MIN	TYP	MAX	UNIT
Input voltage range		-0.2		1	V
Conversion time				31.5	ms
Effective resolution		14		15	bits
Effective input resistance		8			$\text{M}\Omega$

3.9 I²C-COMPATIBLE INTERFACE TIMING CHARACTERISTICS

$T_A = -40^{\circ}\text{C}$ to 85°C , $2.4\text{ V} < V_{CC} < 2.6\text{ V}$; Typical Values at $T_A = 25^{\circ}\text{C}$ and $V_{CC} = 2.5\text{ V}$ (unless otherwise noted)

PARAMETER	TEST CONDITIONS	MIN	TYP	MAX	UNIT
t_r SCL/SDA rise time				1	μs
t_f SCL/SDA fall time				300	ns
$t_{w(\text{H})}$ SCL pulse width (high)		4			μs
$t_{w(\text{L})}$ SCL pulse width (low)		4.7			μs

I²C-COMPATIBLE INTERFACE TIMING CHARACTERISTICS (continued)

T_A = -40°C to 85°C, 2.4 V < V_{CC} < 2.6 V; Typical Values at T_A = 25°C and V_{CC} = 2.5 V (unless otherwise noted)

PARAMETER	TEST CONDITIONS	MIN	TYP	MAX	UNIT
t _{su(STA)}	Setup for repeated start	4.7			μs
t _{d(STA)}	Start to first falling edge of SCL	4			μs
t _{su(DAT)}	Data setup time	250			ns
t _{h(DAT)}	Data hold time	Receive mode	0		ns
		Transmit mode	300		
t _{su(STOP)}	Setup time for stop	4			μs
t _(BUF)	Bus free time between stop and start	4.7			μs
f _(SCL)	Clock frequency			100	kHz
t _(BUSERR)	Bus error timeout	17.3		21.2	s

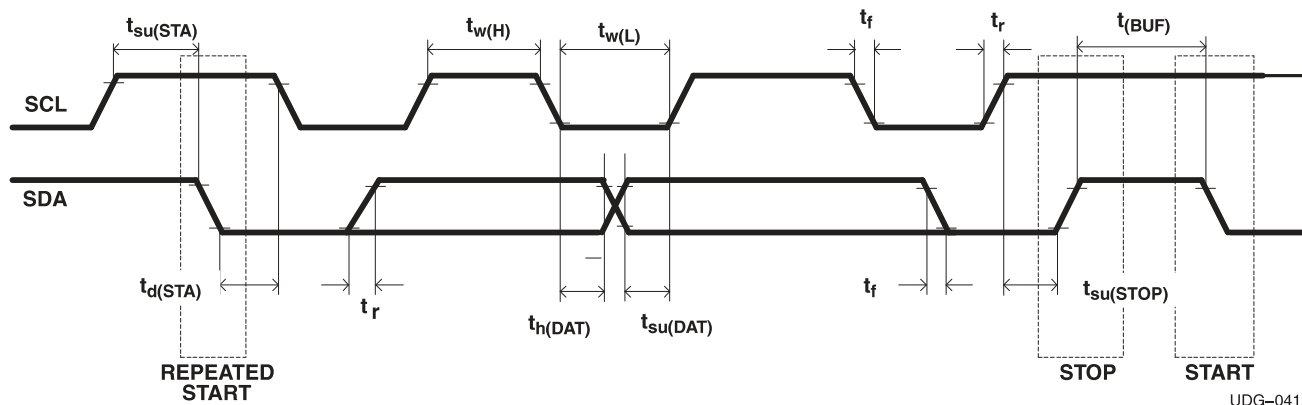

UDG-04122

Figure 3-1. I²C-Compatible Interface Timing Diagram

4 GENERAL DESCRIPTION

The bq27350 accurately predicts the battery capacity and other operational characteristics of a single Li-based rechargeable cell. It can be interrogated by a host processor to provide cell information, such as State-of-Charge (SOC), Time-to-Empty (TTE) and Time-to-Full (TTF).

Information is accessed through a series of commands, called *Standard Commands*. Further capabilities are provided by the additional *Extended Commands* set. Both sets of commands, indicated by the general format *Command()*, are used to read and write information contained within the bq27350's control and status registers, as well as its data flash locations. Commands are sent from host to gauge using the bq27350's I²C engine, and can be executed during application development, pack manufacture, or end-equipment operation.

Cell information is stored inside the bq27350 in non-volatile flash memory. Many of these data flash locations are accessible during application development and pack manufacture. They cannot, generally, be accessed directly during end-equipment operation. Access to these locations is achieved by either use of the bq27350's companion evaluation software, through individual commands, or through a sequence of data-flash-access commands. To access a desired data flash location, the correct data flash subclass and offset must be known.

The bq27350 provides 96 bytes of user-programmable data flash memory, partitioned into 3 32-byte blocks: **Manufacturer Info A**, **Manufacturer Info B**, and **Manufacturer Info C**. This data space is accessed through a data flash interface. For specifics on accessing the data flash, refer to the section entitled *DATA FLASH INTERFACE*.

The key to the bq27350's high-accuracy gas gauging prediction is Texas Instrument's proprietary Impedance Track™ algorithm. This algorithm combines cell measurements, characteristics, and properties to create state-of-charge predictions that can achieve better than 1% accuracy across a wide variety of operating conditions.

The bq27350 measures charge/discharge activity by monitoring the voltage across a small-value series sense resistor (5 mΩ to 20 mΩ typical) between the cell negative terminal and the low-side protection FETs. When an application's load is applied, cell impedance is measured by comparing its Open Circuit Voltage (OCV) with its measured voltage under loading conditions.

The bq27350 can use an external NTC thermistor (default is Semitec 103AT) for temperature measurement, or can also be configured to use its internal temperature sensor. The bq27350 uses temperature to monitor the battery-pack environment, which is used for fuel gauging and cell protection functionality.

To minimize power consumption, the bq27350 has several power modes: NORMAL, SLEEP, HIBERNATE, and SHUTDOWN. The bq27350 passes automatically between these modes, depending upon the occurrence of specific events, though a host processor can initiate some of these modes directly. More details can be found in the section entitled *POWER MODES*.

A battery-pack-authentication feature is also implemented on the bq27350. A scratch pad area is used to both receive challenge information from a host and export SHA-1/HMAC encrypted responses. The bq27350 can perform the encryption directly, or can act as a pass-through to a bq26100 stand-alone authentication IC. Specifics can be found in the section entitled *AUTHENTICATION*.

NOTE

FORMATTING CONVENTIONS:

Commands: *italics with parentheses and no breaking spaces*, e.g. *RemainingCapacity()*.

Data Flash: *italics*, **bold**, and *breaking spaces*, e.g. **Design Capacity**

Register Bits and Flags: brackets only, e.g. [TDA]

Modes and states: ALL CAPITALS, e.g. UNSEALED mode.

4.1 DATA COMMANDS

4.1.1 STANDARD DATA COMMANDS

The bq27350 uses a series of 2-byte standard commands to enable host reading and writing of battery information. Each standard command has an associated command-code pair, as indicated in [Table 4-1](#). Two consecutive I²C transmissions must be executed both to initiate the command function, and to read or write the corresponding two bytes of data. Additional options for transferring data, such as spooling, are described in section *I²C INTERFACE*. Standard commands are accessible in NORMAL operation. Read/write permissions depend on the active access mode.

Table 4-1. Standard Commands

NAME		COMMAND CODE	UNITS	SEALED ACCESS	UNSEALED ACCESS
<i>Control()</i>	CNTL	0x00 / 0x01	N/A	R/W	R/W
<i>AtRate()</i>	AR	0x02 / 0x03	mA	R/W	R/W
<i>AtRateTimeToEmpty()</i>	ARTTE	0x04 / 0x05	Minutes	R	R
<i>Temperature()</i>	TEMP	0x06 / 0x07	0.1°K	R	R
<i>Voltage()</i>	VOLT	0x08 / 0x09	mV	R	R
<i>Flags()</i>	FLAGS	0x0a / 0x0b	N/A	R	R
<i>NominalAvailableCapacity()</i>	NAC	0x0c / 0x0d	mAh	R	R
<i>FullAvailableCapacity()</i>	FAC	0x0e / 0x0f	mAh	R	R
<i>RemainingCapacity()</i>	RM	0x10 / 0x11	mAh	R	R
<i>FullChargeCapacity()</i>	FCC	0x12 / 0x13	mAh	R	R
<i>AverageCurrent()</i>	AI	0x14 / 0x15	mA	R	R
<i>TimeToEmpty()</i>	TTE	0x16 / 0x17	Minutes	R	R
<i>TimeToFull()</i>	TTF	0x18 / 0x19	Minutes	R	R
<i>StandbyCurrent()</i>	SI	0x1a / 0x1b	mA	R	R
<i>StandbyTimeToEmpty()</i>	STTE	0x1c / 0x1d	Minutes	R	R
<i>MaxLoadCurrent()</i>	MLI	0x1e / 0x1f	mA	R	R
<i>MaxLoadTimeToEmpty()</i>	MLTTE	0x20 / 0x21	Minutes	R	R
<i>AvailableEnergy()</i>	AE	0x22 / 0x23	10mWhr	R	R
<i>AveragePower()</i>	AP	0x24 / 0x25	10mW	R	R
<i>TTEatConstantPower()</i>	TTECP	0x26 / 0x27	Minutes	R	R
Reserved	RSVD	0x28 / 0x29	N/A	R	R
<i>CycleCount()</i>	CC	0x2a / 0x2b	Counts	R	R
<i>StateOfCharge()</i>	SOC	0x2c / 0x2d	%	R	R

4.1.1.1 Control(): 0x00/0x01

Issuing a *Control()* command requires a subsequent two-byte sub-command (*little endian* format: least-significant byte written to lowest address location). These additional bytes specify the particular control function desired. The *Control()* command allows the host to control specific features of the bq27350 during normal operation and additional features when the bq27350 is in different access modes, as described in [Table 4-2](#).

Table 4-2. Control() Subcommands

CNTL FUNCTION	CNTL DATA	SEALED ACCESS	DESCRIPTION
CONTROL STATUS	0x0000	Yes	Reports the status of DF Checksum, Hibernate, IT, etc.
DEVICE TYPE	0x0001	Yes	Reports the device type (eg: "bq27350")
FW VERSION	0x0002	Yes	Reports the firmware version on the device type
HW VERSION	0x0003	Yes	Reports the hardware version of the device type
DFCHECKSUM	0x0004	No	Enables a DF checksum to be generated and reports on a read
RESET DATA	0x0005	No	Returns reset data
Reserved	0x0006	No	Not to be used
PREV_MACWRITE	0x0007	No	Returns previous MAC command code
CHEMID	0x0008	Yes	Reports the chemical identifier of the ImpedanceTrack™ configuration
BOARD OFFSET	0x0009	No	Forces the device Board Offset to be measured and stored
CC INT OFFSET	0x000b	No	Forces the device to measure and store the internal CC offset
SET HIBERNATE	0x0011	Yes	Forces DF:Pack Configuration [HIBERNATE] to 1
CLEAR HIBERNATE	0x0012	Yes	Forces DF:Pack Configuration [HIBERNATE] to 0
SEALED	0x0020	No	Places the bq27350 in SEALED access mode
IT ENABLE	0x0021	No	Enables the ImpedanceTrack™ algorithm
IFCHECKSUM	0x0022	No	Reports the instruction flash checksum
CALMODE	0x0040	No	Places the bq27350 in calibration mode
RESET	0x0041	No	Forces a full reset of the bq27350

CONTROL STATUS: 0x0000

Instructs the gas gauge to return status information to Control addresses 0x00/0x01. The status word should include the following information.

Table 4-3. CONTROL STATUS Flags

Flags()	bit7	bit6	bit5	bit4	bit3	bit2	bit1	bit0
High Byte	–	FAS	SS	CSV	CCA	BCA	–	–
Low Byte	–	–	–	–	LDMD	RUP_DIS	VOK	QEN

FAS = Full access sealed (Sealed = 1)

CSV = Indicates a valid DF checksum has been generated

BCA = Board calibration active

RUP_DIS = Indicates Ra table updates disabled

QEN = QMAX updates enabled if set

SS = Sealed state (Sealed = 1)

CCA = Coulomb counter calibration active

LDMD = Indicates Z-track alg, using const. power mode

VOK = Indicates voltages are OK for QMAX update if set

DEVICE TYPE: 0x0001

Instructs the gas gauge to return the device type to addresses 0x00/0x01.

FW_VERSION: 0x0002

Instructs the gas gauge to return the firmware version to addresses 0x00/0x01.

HW_VERSION: 0x0003

Instructs the gas gauge to return the hardware version to addresses 0x00/0x01.

DF CHECKSUM: 0x0004

Instructs the gas gauge to compute the checksum of the data flash memory. The checksum value is written and returned to addresses 0x00/0x01 (UNSEALED mode only). The checksum will not be calculated in SEALED mode; however, the checksum value can still be read.

RESET_DATA: 0x0005

Instructs the gas gauge to return the reset data to addresses 0x00/0x01, with the low-byte being the number of partial resets and the high-byte the number of full resets.

PREV_MACWRITE: 0x0007

Instructs the gas gauge to return the previous command written to addresses 0x00/0x01.

CHEM ID: 0x0008

Instructs the gas gauge to return the chemical identifier for the ImpedanceTrack™ configuration to addresses 0x00/0x01.

BOARD_OFFSET: 0x0009

Instructs the gas gauge to compute the coulomb counter offset with internal short and without internal short applied across the SR inputs. The difference between the two measurements is the Board Offset. The Board Offset shall be written to data flash and should also be returned to addresses 0x00/0x01. User will need to prevent any charge or discharge current from flowing during the process. This function is only available when the gas gauge is UNSEALED. When SEALED, this command will only read back the Board Offset value stored in data flash.

CC_INT_OFFSET: 0x000B

Instructs the gas gauge to compute the coulomb counter offset with internal short applied across the SR inputs. The offset value shall be written to Data Flash and should also be returned to addresses 0x00/0x01. This function is only available when the gas gauge is UNSEALED. When SEALED, this command will only read back the CC_INT_OFFSET value stored in data flash.

SET_HIBERNATE: 0x0011

Instructs the gas gauge to force **Pack Configuration's [HIBERNATE]** bit to 1. This will allow the gauge to enter the HIBERNATE power mode after the transition to SLEEP power state is detected.

CLEAR_HIBERNATE: 0x0012

Instructs the gas gauge to force **Pack Configuration's [HIBERNATE]** bit to 0. This will prevent the gauge from entering the HIBERNATE power mode after the transition to SLEEP power state is detected.

SEALED: 0x0020

Instructs the gas gauge to transition from UNSEALED state to SEALED state. The gas gauge should always be set to SEALED state for use in customer's end equipment.

IT ENABLE: 0x0021

This command forces the gas gauge to begin the Impedance Track™ algorithm, sets **UpdateStatus** to 0x04 and causes the [VOK] and [QEN] flags to be set in the CONTROL STATUS register. [VOK] is cleared if the voltages are not suitable for a Qmax update. Once set, [QEN] cannot be cleared. This command is only available when the gas gauge is UNSEALED.

IF CHECKSUM: 0x0022

This command instructs the gas gauge to compute the instruction flash checksum. In UNSEALED mode, the checksum value is returned to addresses 0x00/0x01. The checksum will not be calculated in SEALED mode; however, the checksum value can still be read.

CAL MODE: 0x0040

This command instructs the gas gauge to enter calibration mode. This command is only available when the gas gauge is UNSEALED.

RESET : 0x0041

This command instructs the gas gauge to perform a full reset. This command is only available when the gas gauge is UNSEALED.

4.1.1.2 AtRate(): 0x02/0x03

The *AtRate()* read/write-word function is the first half of a two-function call-set used to set the *AtRate* value used in calculations made by the *AtRateTimeToEmpty()* function. The *AtRate()* units are in mA.

The *AtRate()* value is a signed integer and both positive and negative values will be interpreted as a discharge current value. The *AtRateTimeToEmpty()* function returns the predicted operating time at the *AtRate* value of discharge. The default value for *AtRate()* is zero and will force *AtRate()* to return 65535.

4.1.1.3 AtRateTimeToEmpty(): 0x04/0x05

This read-word function returns an unsigned integer value of the predicted remaining operating time if the battery is discharged at the *AtRate()* value in minutes with a range of 0 to 65534. A value of 65535 indicates *AtRate()* = 0. The gas gauge updates *AtRateTimeToEmpty()* within 1s after the host sets the *AtRate()* value. The gas gauge automatically updates *AtRateTimeToEmpty()* based on the *AtRate()* value every 1s.

4.1.1.4 Temperature(): 0x06/0x07

This read-word function returns an unsigned integer value of the temperature in units of 0.1°K measured by the gas gauge and has a range of 0 to 6553.5°K. The source of the measured temperature is configured by the [TEMPS] bit in **Pack Configuration** register (see *EXTENDED COMMANDS*).

Table 4-4. Temperature Sensor Selection

TEMPS	Temperature() source
0	Internal Temperature Sensor
1	TS Input (default)

4.1.1.5 Voltage(): 0x08/0x09

This read-word function returns an unsigned integer value of the measured cell-pack voltage in mV with a range of 0 to 6000mV.

4.1.1.6 Flags(): 0x0a/0x0b

This read-word function returns the contents of the gas-gauge status register, depicting current operation status.

Table 4-5. Flags Bit Definitions

	bit7	bit6	bit5	bit4	bit3	bit2	bit1	bit0
High Byte	OTC	OTD	–	–	–	XCHG	CHG_INH	CHG
Low Byte	CC_OFF	–	–	–	FC	RCA	TDA	DSG

OTC = Over-Temperature in Charge condition is detected

CC_OFF = Coulomb Counter Offset measurement is being performed

OTD = Over-Temperature in Discharge condition is detected

FC = Fully Charged, set when Charge termination condition is met

RCA = Remaining Capacity Alert

XCHG = Charge Suspend Alert (temp outside the range –5°C to 55°C)

CHG_INH = Charge Inhibit: unable to begin charging (temp outside the range 0°C to 45°C)

TDA = Terminate Discharge Alert

CHG = (Fast)charging allowed

DSG = Discharging detected

4.1.1.7 NominalAvailableCapacity(): 0x0c/0x0d

This read-only command pair returns the uncompensated (no or light load) battery capacity remaining. Units are 1mAh per bit.

4.1.1.8 FullAvailableCapacity(): 0x0e/0x0f

This read-only command pair returns the uncompensated (no or light load) capacity of the battery when fully charged. Units are 1mAh per bit. *FullAvailableCapacity()* is updated at regular intervals, as specified by the IT algorithm.

4.1.1.9 RemainingCapacity(): 0x10/0x11

This read-only command pair returns the compensated battery capacity remaining. Units are 1mAh per bit.

4.1.1.10 FullChargeCapacity(): 0x12/13

This read-only command pair returns the compensated capacity of the battery when fully charged. Units are 1mAh per bit. *FullChargeCapacity()* is updated at regular intervals, as specified by the IT algorithm.

4.1.1.11 AverageCurrent(): 0x14/0x15

This read-only command pair returns a signed integer value that is the average current flow through the sense resistor. It is updated every 1 second. Units are 1mA per bit.

4.1.1.12 TimeToEmpty(): 0x16/0x17

This read-only function returns an unsigned integer value of the predicted remaining battery life at the present rate of discharge, in minutes. A value of 65535 indicates battery is not being discharged.

4.1.1.13 TimeToFull(): 0x18/0x19

This read-only function returns an unsigned integer value of predicted remaining time until the battery reaches full charge, in minutes, based upon *AverageCurrent()*. The computation should account for the taper current time extension from the linear TTF computation based on a fixed *AverageCurrent()* rate of charge accumulation. A value of 65535 indicates the battery is not being charged.

4.1.1.14 StandbyCurrent(): 0x1a/0x1b

This read-only function returns a signed integer value of the measured standby current through the sense resistor. The *StandbyCurrent()* is an adaptive measurement. Initially it reports the standby current programmed in **Initial Standby**, and after spending some time in standby, reports the measured standby current.

The register value is updated every 1 second when the measured current is above the **Deadband** (3mA default) and is less than or equal to $2 \times$ **Initial Standby**. The first and last values that meet this criteria should not be averaged in, since they may not be stable values. To approximate a 1 minute time constant, each new *StandbyCurrent()* value is computed as follows:

$$\text{StandbyCurrent}()_{NEW} = (239/256) \times \text{StandbyCurrent}()_{OLD} + (17/256) \times \text{AverageCurrent}().$$

4.1.1.15 StandbyTimeToEmpty(): 0x1c/0x1d

This read-only function returns an unsigned integer value of the predicted remaining battery life at the standby rate of discharge, in minutes. The computation should use *Nominal Available Capacity* (NAC), the uncompensated remaining capacity, for this computation. A value of 65535 indicates battery is not being discharged.

4.1.1.16 MaxLoadCurrent(): 0x1e/0x1f

This read-only function returns a signed integer value, in units of mA, of the maximum load conditions. The *MaxLoadCurrent()* is an adaptive measurement which is initially it reports the maximum load current programmed in **Initial Max Load Current**. If the measured current is ever greater than **Initial Max Load Current**, then *MaxLoadCurrent()* updates to the new current. *MaxLoadCurrent()* is reduced to the average of the previous value and **Initial Max Load Current** whenever the battery is charged to full after a previous discharge to an SOC less than 50%. This prevents the reported value from maintaining an unusually high value.

4.1.1.17 MaxLoadTimeToEmpty(): 0x20/0x21

This read-only function returns an unsigned integer value of the predicted remaining battery life at the maximum load current discharge rate, in minutes. A value of 65535 indicates that the battery is not being discharged.

4.1.1.18 AvailableEnergy(): 0x22/0x23

This read-only function returns an unsigned integer value of the predicted charge or energy remaining in the battery. The value is reported in units of mWh.

4.1.1.19 AveragePower(): 0x24/0x25

This read-word function returns an unsigned integer value of the average power of the current discharge. A value of 0 indicates that the battery is not being discharged. The value is reported in units of mW.

4.1.1.20 TimeToEmptyAtConstantPower(): 0x26/0x27

This read-only function returns an unsigned integer value of the predicted remaining operating time if the battery is discharged at the *AveragePower()* value in minutes. A value of 65535 indicates *AveragePower()* = 0. The gas gauge automatically updates *TimeToEmptyatContantPower()* based on the *AveragePower()* value every 1s.

4.1.1.21 CycleCount(): 0x2a/0x2b

This read-only function returns an unsigned integer value of the number of cycles the battery has experienced with a range of 0 to 65535. One cycle occurs when accumulated discharge \geq **CC Threshold**.

4.1.1.22 StateOfCharge(): 0x2c/0x2d

This read-only function returns an unsigned integer value of the predicted remaining battery capacity expressed as a percentage of *FullChargeCapacity()*, with a range of 0 to 100%.

4.2 EXTENDED DATA COMMANDS

Extended commands offer additional functionality beyond the standard set of commands. They are used in the same manner; however unlike standard commands, extended commands are not limited to 2-byte words. The number of commands bytes for a given extended command ranges in size from single to multiple bytes, as specified in [Table 4-6](#). For details on the SEALED and UNSEALED states, refer to the section *Access Modes*.

Table 4-6. Extended Data Commands

NAME		COMMAND CODE	UNITS	SEALED ACCESS ^{(1) (2)}	UNSEALED ACCESS ^{(1) (2)}
Reserved	RSVD	0x34 / 0x39	N/A	R	R
<i>PackConfiguration()</i>	PKCFG	0x3a / 0x3b	N/A	R	R
<i>DesignCapacity()</i>	DCAP	0x3c / 0x3d	mAh	R	R
<i>DataFlashClass()</i> ⁽²⁾	DFCLS	0x3e	N/A	N/A	R/W
<i>DataFlashBlock()</i> ⁽²⁾	DFBLK	0x3f	N/A	R/W	R/W
<i>Authenticate()/BlockData()</i>	A/DF	0x40...0x53	N/A	R/W	R/W
<i>AuthenticateChecksum()/BlockData()</i>	ACKS/DFD	0x54	N/A	R/W	R/W
<i>BlockData()</i>	DFD	0x55...0x5f	N/A	R	R/W
<i>BlockDataChecksum()</i>	DFDCKS	0x60	N/A	R/W	R/W
<i>BlockDataControl()</i>	DFDCNTL	0x61	N/A	N/A	R/W
<i>DeviceNameLength()</i>	DNAMELEN	0x62	N/A	R	R
<i>DeviceName()</i>	DNAME	0x63...0x69	N/A	R	R
Reserved	RSVD	0x6a...0x7f	N/A	R	R

(1) SEALED and UNSEALED states are entered via commands to CNTL 0x00/0x01

(2) In sealed mode, data flash CANNOT be accessed through commands 0x3e and 0x3f.

4.2.1 *PackConfiguration()*: 0x3a/0x3b

This Read-Word function allows the host to read the configuration of selected features of the bq27350 pertaining to power modes and transitioning between them. These features must set direct by data flash writes to location subclass = 64, offset = 0 while in UNSEALED mode. Only the HIBERNATE function can be modified while SEALED mode with the *Control()* command.

Table 4-7. Pack Configuration Bit Definitions

Operation Cfg	bit7	bit6	bit5	bit4	bit3	bit2	bit1	bit0
High Byte	RESCAP	–	BUSLOW	–	–	IWAKE	RSNS1	RSNS0
Low Byte	SHUTDOWN	HIBERNATE	SLEEP	RMFCC	–	–	–	TEMPS

RESCAP = If set, no-load rate of compensation is applied to the reserve capacity calculation

BUSLOW = If set, the Interface Bus being low becomes a requirement to enter SLEEP mode

IWAKE/RSNS1/RSNS0 = These bits configure the current wake function (ref. [Table 5-3](#))

SHUTDOWN = If set, \overline{SE} is set high before going into HIBERNATE and set low in NORMAL mode

HIBERNATE = If set and conditions are suitable for SLEEP mode, then the gas gauge enters HIBERNATE instead of SLEEP

SLEEP = If set, the gas gauge can enter SLEEP mode if operating conditions allow

RMFCC = If set, on valid charge termination RM is updated with the value from FCC

TEMPS = Selects Temperature() source, 0 = Internal, 1 = External

4.2.2 *DesignCapacity()*: 0x3c/0x3d

SEALED and UNSEALED Access: This command returns the theoretical or nominal capacity of a new pack. The value is stored in **Design Capacity** and is expressed in mAh.

4.2.3 *DataFlashClass()*: 0x3e

UNSEALED Access: This command sets the data flash class to be accessed. The class to be accessed should be entered in hexadecimal.

SEALED Access: This command is not available in SEALED mode.

4.2.4 **DataFlashBlock(): 0x3f**

UNSEALED Access: This command sets the data flash block to be accessed. When “0x00” is written to *BlockDataControl()*, *DataFlashBlock()* holds the block number of the data flash to be read or written. Example: writing a 0x00 to *DataFlashBlock()* specifies access to the first 32 byte block and a 0x01 specifies access to the second 32 byte block, and so on.

SEALED Access: This command directs which data flash block will be accessed by the *BlockData()* command. Writing a 0x00 to *DataFlashBlock()* specifies the *BlockData()* command will transfer authentication data. Issuing a 0x01, 0x02 or 0x03 instructs the *BlockData()* command to transfer **Manufacturer Info Blocks A, B, or C**, respectively.

4.2.5 **AuthenticateData/BlockData(): 0x40...0x53**

UNSEALED Access: This data block has two functions. It is used for the authentication challenge and response and is part of the 32 byte data block when accessing data flash.

SEALED Access: It is used for the authentication challenge and response and is part of the 32 byte data block when accessing **Manufacturer Info Blocks A, B, or C**.

4.2.6 **AuthenticateChecksum/BlockData(): 0x54**

UNSEALED Access: This byte holds the authenticate checksum when writing the authentication challenge to the bq27350 and is part of the 32 byte data block when accessing data flash.

SEALED Access: This byte holds the authenticate checksum when writing the authentication challenge to the bq27350 and is part of the 32 byte data block when accessing **Manufacturer Info Blocks A, B, or C**.

4.2.7 **BlockData(): 0x55...0x5f**

UNSEALED Access: This data block is the remainder of the 32 byte data block when accessing data flash.

SEALED Access: This data block is the remainder of the 32 byte data block when accessing **Manufacturer Info Blocks A, B, or C**.

4.2.8 **BlockDataChecksum(): 0x60**

UNSEALED Access: This byte contains the checksum for the 32 bytes of block data read or written to data flash.

SEALED Access: This byte contains the checksum for the 32 bytes of block data written to **Manufacturer Info Blocks B or C**.

4.2.9 **BlockDataControl(): 0x61**

UNSEALED Access: This command is used to control data flash access. Writing 0x00 to this command enables *BlockData()* to access general data flash. Writing a 0x01 to this command enables *BlockData()* to access authentication challenge and response.

SEALED Access: This command is not available in SEALED mode.

4.2.10 **DeviceNameLength(): 0x62**

UNSEALED and SEALED Access: This byte contains the length of the **Device Name**.

4.2.11 **DeviceName(): 0x63...0x69**

UNSEALED and SEALED Access: This block contains the device name that is programmed in **Device Name**.

4.2.12 Reserved – 0x6A – 0x7F

4.3 DATA FLASH INTERFACE

4.3.1 ACCESSING THE DATA FLASH

The bq27350 data flash is a non-volatile memory that contains bq27350 initialization, default, cell status, calibration, configuration, and user information. The data flash can be accessed in several different ways, depending on what mode the bq27350 is operating in and what data is being accessed.

Commonly accessed data flash memory locations, frequently read by a host, are conveniently accessed through specific instructions, already described in the *DATA COMMANDS* section. These commands are available when the bq27350 is either in UNSEALED or SEALED modes.

Most data flash locations, however, can only be accessed in UNSEALED mode by using the bq27350 evaluation software or by performing data flash block transfers. These locations should be optimized and/or fixed during the development and manufacture processes. They become part of a *golden pack* file and can then be written to multiple battery packs. Once established, the values generally remain unchanged during end-equipment operation.

To access data flash locations individually, the block containing the desired data flash location(s) must be transferred to the command register locations, where they can be read to the host or changed directly. This is accomplished by sending the set-up command *BlockDataControl()* (code 0x61) with data 0x00. Up to 32 bytes of data can be read directly from the *BlockData()* command locations 0x40...0x5f, externally altered, then re-written to the *BlockData()* command space. Alternatively, specific locations can be read, altered, and re-written if their corresponding offsets are used to index into the *BlockData()* command space. Finally, data residing in the command space is transferred to data flash, once a correct checksum for the whole block is written to *BlockDataChecksum()* (command number 0x60).

Occasionally, a data flash CLASS will be larger than the 32-byte block size. In this case, the *DataFlashBlock()* command is used to designate which 32-byte block the desired locations reside in. The correct command address is then given by $0x40 + \text{offset} \text{ modulo } 32$. For example, to access **Terminate Voltage** in the *Gas Gauging* class, *DataFlashClass()* is issued 80 (0x50) to set the class. Because the offset is 48, it must reside in the second 32-byte block. Hence *DataFlashBlock()* is issued 0x01 to set the block offset, and the offset used to index into the *BlockData()* memory area is $0x40 + 48 \text{ modulo } 32 = 0x40 + 16 = 0x40 + 0x10 = 0x50$.

Reading and writing subclass data are block operations 32 bytes in length. Data can be written in shorter block sizes, however. Blocks can be shorter than 32 bytes in length. Writing these blocks back to data flash will not overwrite data that extends beyond the actual block length.

None of the data written to memory are bounded by the bq27350 — the values are not rejected by the gas gauge. Writing an incorrect value may result in hardware failure due to firmware program interpretation of the invalid data. The data written is persistent, so a Power-On-Reset does not resolve the fault.

4.4 MANUFACTURER INFORMATION BLOCKS

The bq27350 contains 96 bytes of user programmable data flash storage: **Manufacturer Info Block A**, **Manufacturer Info Block B**, **Manufacturer Info Block C**. The method for accessing these memory locations is slightly different, depending on whether the device is in UNSEALED or SEALED modes.

When in UNSEALED mode and “0x00” is written to *BlockDataControl()*, accessing the Manufacturer Info Blocks is identical to accessing general data flash locations. First, a *DataFlashClass()* command is used to set the subclass, then a *DataFlashBlock()* command sets the offset for the first data flash address within the subclass. The *BlockData()* command codes contain the referenced data flash data. When writing the data flash, a checksum is expected to be received by *BlockDataChecksum()*. Only when the checksum is received and verified is the data actually written to data flash.

As an example, the data flash location for **Manufacturer Info Block B** is defined as having a Subclass = 58 and an Offset = 32 through 63 (32 byte block). The specification of Class = "System Data" is not needed to address **Manufacturer Info Block B**, but is used instead for grouping purposes when viewing data flash info in the bq27350 evaluation software.

When in SEALED mode or "0x01" has been written to *BlockDataControl()*, data flash is no longer available in the manner used in UNSEALED mode. Rather than issuing subclass information, a designated Manufacturer Information Block is selected with the *DataFlashBlock()* command. Issuing a 0x01, 0x02, or 0x03 with this command causes the corresponding information block (A, B, or C, respectively) to be transferred to the command space 0x40...0x5f for editing or reading by the host. Upon successful writing of checksum information to *BlockDataChecksum()*, the modified block is returned to data flash. **Note:** **Manufacturer Info Block A** is "read only" when in SEALED mode.

4.5 ACCESS MODES

The bq27350 provides three security modes in which control data flash access permissions according to [Table 4-8](#). *Public Access* refers to those data flash locations, specified in [Table 4-9](#), that are accessible to the user. *Private Access* refers to reserved data flash locations used by the bq27350 system. Care should be taken to avoid writing to *Private* data flash locations when performing block writes in *Full Access* mode, by following the procedure outlined in *ACCESSING THE DATAFLASH*.

Table 4-8. Data Flash Access

Security Mode	DF – Public Access	DF – Private Access
BOOTROM	N/A	N/A
FULL ACCESS	R/W	R/W
UNSEALED	R/W	R/W
SEALED	R	N/A

Although FULL ACCESS and UNSEALED modes appear identical, FULL ACCESS allows the bq27350 to directly transition to BOOTROM mode and write access keys. The UNSEAL mode lacks these abilities.

4.6 SEALING/UNSEALING DATA FLASH ACCESS

The bq27350 implements a key-access scheme to transition between SEALED, UNSEALED, and FULL-ACCESS modes. Each transition requires that a unique set of 2 keys be sent to the bq27350 via the *Control()* control command (these keys are unrelated to the keys used for SHA-1/HMAC authentication). The keys must be sent consecutively, with no other data being written to the *Control()* register in between. Note that to avoid conflict, the keys must be selected different from the codes presented in the *CNTL DATA* column of [Table 4-2](#) *Control()* subcommands.

When in SEALED mode the *Control Status()*'s [SS] bit is set, but when the UNSEAL keys are correctly received by the bq27350, the [SS] bit is cleared. When the full access keys are correctly received then the *Control Status()* [FAS] bit is cleared.

Both the sets of keys for each level are 2 bytes each in length and are stored in data flash. The UNSEAL key (stored at **Unseal Key 0** and **Unseal Key 1**) and the FULL-ACCESS key (stored at **Full Access Key 0** and **Full Access Key 1**) can only be updated when in FULL-ACCESS Mode. The order of the bytes entered through the *Control()* command is the reverse of what is read from the part. For example, if the 1st and 2nd word of **Unseal Key 0** read returns 0x1234 and 0x5678, then the *Control()* should supply 0x3412 and 0x7856 to unseal the part.

4.7 DATA FLASH SUMMARY

[Table 4-9](#) summarizes the data flash locations available to the user, including their default, minimum, and maximum values.

Table 4-9. Data Flash Summary

Class	Subclass ID	Subclass	Offset	Name	Data Type	Min Value	Max Value	Default Value	Units
Configuration	2	Safety	0	OT Chg	I2	0	1200	550	0.1°C
Configuration	2	Safety	2	OT Chg Time	U1	0	60	2	s
Configuration	2	Safety	3	OT Chg Recovery	I2	0	1200	500	0.1°C
Configuration	2	Safety	5	OT Dsg	I2	0	1200	600	0.1°C
Configuration	2	Safety	7	OT Dsg Time	U1	0	60	2	s
Configuration	2	Safety	8	OT Dsg Recovery	I2	0	1200	550	0.1°C
Configuration	34	Charge	2	Charging Voltage	I2	0	20000	4200	mV
Configuration	36	Charge Termination	2	Taper Current	I2	0	1000	100	mA
Configuration	36	Charge Termination	6	Taper Voltage	I2	0	1000	100	mV
Configuration	36	Charge Termination	8	Current Taper Window	U1	0	60	40	s
Configuration	48	Data	0	RCA Set	I2	0	700	100	mAh
Configuration	48	Data	8	Initial Standby Current	I1	-256	0	-10	mA
Configuration	48	Data	9	Initial Max Load Current	I2	-32767	0	-1000	mA
Configuration	48	Data	17	Cycle Count	U2	0	65535	0	Count
Configuration	48	Data	19	CC Threshold	I2	100	32767	1400	mAh
Configuration	48	Data	23	Design Capacity	I2	0	65535	1500	mAh
Configuration	48	Data	39	Device Name	S8	x	x	bq27350	
Configuration	49	Discharge	0	TDA Set %	I1	-1	100	6	%
Configuration	49	Discharge	1	TDA Clear %	I1	-1	100	8	%
System Data	58	Manufacturer Info	0 – 31	Block A [0 – 31]	H1	0x00	0xff	0x00	
System Data	58	Manufacturer Info	32 – 63	Block B [0 – 31]	H1	0x00	0xff	0x00	
System Data	58	Manufacturer Info	64 – 95	Block C [0 – 31]	H1	0x00	0xff	0x00	
Configuration	64	Registers	0	Pack Configuration	H2	0x0000	0xffff	0x0131	
Configuration	68	Power	0	Flash Update OK Voltage	I2	2400	4200	2800	mV
Configuration	68	Power	7	Sleep Current	I2	0	100	10	mA
Gas Gauging	80	IT Cfg	0	Load Select	U1	0	255	1	
Gas Gauging	80	IT Cfg	1	Load Mode	U1	0	255	0	
Gas Gauging	80	IT Cfg	48	Terminate Voltage	I2	-32768	32767	3000	mV
Gas Gauging	80	IT Cfg	63	User Rate-mA	I2	0	9000	0	mA
Gas Gauging	80	IT Cfg	65	User Rate-mW	I2	0	14000	0	10mW
Gas Gauging	80	IT Cfg	67	Reserve Cap-mAh	I2	0	9000	0	mAh
Gas Gauging	80	IT Cfg	69	Reserve Cap-mWh	I2	0	14000	0	10mWh
Gas Gauging	81	Current Thresholds	0	Dsg Current Threshold	I2	0	2000	75	mA
Gas Gauging	81	Current Thresholds	2	Chg Current Threshold	I2	0	2000	75	mA
Gas Gauging	81	Current Thresholds	4	Quit Current	I2	0	1000	50	mA
Gas Gauging	81	Current Thresholds	6	Dsg Relax Time	U2	0	8191	1800	s
Gas Gauging	81	Current Thresholds	8	Chg Relax Time	U1	0	255	60	s
Gas Gauging	81	Current Thresholds	9	Quit Relax Time	U1	0	63	1	s
Gas Gauging	82	State	0	Qmax Cell 0	I2	0	32767	1500	mAh

Table 4-9. Data Flash Summary (continued)

Class	Subclass ID	Subclass	Offset	Name	Data Type	Min Value	Max Value	Default Value	Units
Gas Gauging	82	State	2	Qmax Pack	I2	0	32767	1500	mAh
Gas Gauging	82	State	6	Update Status	H1	0x00	0x06	0x0	
Gas Gauging	82	State	9	Avg I Last Run	I2	–32768	32767	–2000	mA
Gas Gauging	82	State	11	Avg P Last Run	I2	–32768	32767	–3022	mW
Ra Table	88	R_a0	0	Cell0 R_a flag	H2	0x0000	0x0000	0xff55	
Ra Table	88	R_a0	2 – 30	Cell0 R_a [0 –14]	I2	183	183	160	2 ¹⁰ Ω
Ra Table	89	R_a0x	0	xCell0 R_a flag	H2	0xffff	0xffff	0xffff	
Ra Table	89	R_a0x	2 – 30	xCell0 R_a [0 –14]	I2	183	183	160	2 ¹⁰ Ω
Calibration	104	Data	0	CC Gain	F4	0.1	4	0.9419	
Calibration	104	Data	4	CC Delta	F4	0.1	4	0.9419	
Calibration	104	Data	8	Ref Voltage	I2	0	32767	1225	
Calibration	104	Data	10	CC Offset	I2	–32768	32767	–1667	
Calibration	104	Data	12	Board Offset	I2	–32767	32767	0	
Calibration	104	Data	14	Int Temp Offset	I1	–128	127	0	
Calibration	104	Data	15	Ext1 Temp Offset	I1	–128	127	0	
Calibration	107	Current	1	Deadband	U1	0	255	3	mA

5 FUNCTIONAL DESCRIPTION

5.1 FUEL GAUGING

The bq27350 measures the cell voltage, temperature, and current to determine battery SOC. The bq27350 monitors charge and discharge activity by sensing the voltage across a small-value resistor (5mΩ to 20 mΩ typ.) between the SRP and SRN pins and in-series with the cell. By integrating charge passing through the battery, the cell's SOC is adjusted during battery charge or discharge.

The total battery capacity is found by comparing states of charge before and after applying the load with the amount of charge passed. When an application load is applied, the impedance of the cell is measured by comparing the OCV obtained from a predefined function for present SOC with the measured voltage under load. Measurements of OCV and charge integration determine chemical state of charge and Chemical Capacity (Qmax). The initial **Qmax** value is taken from a cell manufacturers' data sheet multiplied by the number of parallel cells. It is also used for the value in **Design Capacity**. The bq27350 acquires and updates the battery-impedance profile during normal battery usage. It uses this profile, along with SOC and the **Qmax** value, to determine *FullChargeCapacity()* and *StateOfCharge()* specifically for the present load and temperature. *FullChargeCapacity()* is reported as capacity available from a fully charged battery under the present load and temperature until *Voltage()* reaches the **Terminate Voltage**. *NominalAvailableCapacity()* and *FullAvailableCapacity()* are the uncompensated (no or light load) versions of *RemainingCapacity()* and *FullChargeCapacity()* respectively.

The bq27350 has two flags accessed by the *Flags()* function that warns when the cell's SOC has fallen to critical levels. When *RemainingCapacity()* falls below the first capacity threshold, specified in **RCA Set**, the [RCA] ("Remaining Capacity Alert") flag is set. The flag is cleared once *RemainingCapacity()* rises above **RCA Set**. All units are in mAh.

When *StateOfCharge()* falls below the second capacity threshold, **TDA Set %**, the [TDA] ("Terminate Discharge Alert") flag is set, serving as a final discharge warning. If **TDA Set %** = -1, the flag is inoperative during discharge.

Similarly, when *StateOfCharge()* rises above **TDA Clear %** and the [TDA] flag has already been set, the [TDA] flag will be cleared, provided **TDA Set %** ≠ -1. All units are in percentages.

5.2 IMPEDANCE TRACK VARIABLES

The bq27350 has several data flash variables that permit the user to customize the Impedance Track algorithm for optimized performance. These variables are dependent upon the power characteristics of the application as well as the cell itself.

Load Mode

Load Mode is used to select either the constant current or constant power model for the Impedance Track™ algorithm as used in *Load Select* (see *Load Select*). When *Load Mode* is 0, the Constant Current Model is used (default). When 1, the Constant Power Model is used.

Load Select

Load Select defines the type of power or current model to be used to compute load-compensated capacity in the Impedance Track™ algorithm. If *Load Mode* = 0 ('Constant Current') then the options presented in [Table 5-1](#) are available.

Table 5-1. Constant-Current Model Used When Load Mode = 0

LoadSelect Value	Current Model Used
0	Average discharge current from previous cycle: There is an internal register that records the average discharge current through each entire discharge cycle. The previous average is stored in this register.
1(default)	Present average discharge current: This is the average discharge current from the beginning of this discharge cycle until present time.
2	Average Current: based on <i>AverageCurrent()</i>
3	Current: based off of a low-pass-filtered version of <i>AverageCurrent()</i> ($\tau = 14s$)
4	Design Capacity / 5: C Rate based off of Design Capacity /5 or a C / 5 rate in mA.
5	AtRate (mA): Use whatever current is in <i>AtRate()</i>
6	User_Rate-mA: Use the value in <i>User_Rate()</i> . This gives a completely user configurable method.

If *Load Mode* = 1 ('Constant Power') then the following options are available:

Table 5-2. Constant-Power Model Used When Load Mode = 1

LoadSelect Value	Power Model Used
0	Average discharge power from previous cycle: There is an internal register that records the average discharge power through each entire discharge cycle. The previous average is stored in this register.
1(default)	Present average discharge power: This is the average discharge power from the beginning of this discharge cycle until present time.
2	Average CurrentxVoltage: based off the <i>AverageCurrent()</i> and <i>Voltage()</i> .
3	Current xVoltage: based off of a low-pass-filtered version of <i>AverageCurrent()</i> ($\tau = 14s$) and <i>Voltage()</i>
4	Design Energy / 5: C Rate based off of Design Energy /5 or a C / 5 rate in mA.
5	AtRate (10 mW): Use whatever value is in <i>AtRate()</i> .
6	User_Rate-10mW: Use the value in <i>User_Rate()</i> mW. This gives a completely user configurable method.

Reserve Cap-mAh

Reserve Cap-mAh determines how much actual remaining capacity exists after reaching 0 *RemainingCapacity()*, before *Terminate Voltage* is reached. A no-load rate of compensation is applied to this reserve.

Reserve Cap-mWh

Reserve Cap-mWh determines how much actual remaining capacity exists after reaching 0 *AvailableEnergy()*, before *Terminate Voltage* is reached. A no-load rate of compensation is applied to this reserve capacity.

Dsg Current Threshold

This register is used as a threshold by many functions in the bq27350 to determine if actual discharge current is flowing into or out of the cell. The default for this register is 100mA which should be sufficient for most applications. This threshold should be set low enough to be below any normal application load current but high enough to prevent noise or drift from affecting the measurement.

Chg Current Threshold

This register is used as a threshold by many functions in the bq27350 to determine if actual charge current is flowing into or out of the cell. The default for this register is 50mA which should be sufficient for most applications. This threshold should be set low enough to be below any normal charge current but high enough to prevent noise or drift from affecting the measurement.

Quit Current, Dsg Relax Time, Chg Relax Time, and Quit Relax Time

The **Quit Current** is used as part of the Impedance Track™ algorithm to determine when the bq27350 enters relaxation mode from a current flowing mode in either the charge direction or the discharge direction. The value of *Quit Current* is set to a default value of 10mA and should be above the standby current of the host system, but not exceed the C/20 rate..

Either of the following criteria must be met to enter relaxation mode:

1. $|AverageCurrent()| < |Quit\ Current|$ for **Dsg Relax Time**.
2. $|AverageCurrent()| < |Quit\ Current|$ for **Chg Relax Time**.

After about 30 minutes in relaxation mode, and when voltage change rate satisfies the criteria $dV/dt < 4\mu V/sec$, the bq27350 attempts to take accurate OCV readings. If state of charge (SOC) change from the previous OCV reading exceeds 37% when a new reading is taken, the total cell capacity, **Qmax**, is updated. These updates are used in the Impedance Track™ algorithms. It is critical that the battery voltage be relaxed during OCV readings and that the current is not higher than C/20 when attempting to go into relaxation mode.

Quit Relax Time specifies the minimum time required for *AverageCurrent()* to remain above the **QuitCurrent** threshold before exiting relaxation mode.

Qmax

Qmax contains the maximum chemical capacity of a cell and is determined by comparing states of charge, before and after applying a load, with the amount of charge that passed. It also corresponds to capacity at very low rate of discharge such as C/20 rate. For high accuracy, this value is periodically updated by the bq27350 during operation. The initial value of **Qmax** should be set to the battery cell capacity specified in its datasheet.

Update Status

There are 2 bits in this register that are important

- Bit 1 (0x02) indicates that the bq27350 has learned new **Qmax** parameters and is accurate.
- Bit 2 (0x04) indicates whether Impedance Track™ algorithm is enabled.

The remaining bits are reserved. Bits 1 and 2 are user-configurable; however, bit 1 is also a status flag that can be set by the bq27350. These bits should never be modified except when creating a golden image file as explained in the application note “Preparing Optimized Default Flash Constants for specific Battery Types” (see [SLUA334.pdf](#)). Bit 1 is updated as needed by the bq27350 and Bit 2 is set with *Control()* command 0x0021.

Avg I Last Run

The bq27350 logs the current averaged from the beginning to the end of each discharge cycle. It stores this average current from the previous discharge cycle in this register. This register should never need to be modified. It is only updated by the bq27350 when required.

Avg P Last Run

The bq27350 logs the power averaged from the beginning to the end of each discharge cycle. It stores this average power from the previous discharge cycle in this register. To get a correct average power reading the bq27350 continuously multiplies instantaneous current times *Voltage()* to get power. It then logs this data to derive the average power. This register should never need to be modified. It is only updated by the bq27350 when the required.

The Ra Tables

This data is automatically updated during device operation. No user changes should be made except for reading the values from another pre-learned pack for creating “Golden Image Files”. Profiles have format *Cell0 R_a M*, where *M* is the number indicating state of charge to which the value corresponds.

5.3 TEMPERATURE MEASUREMENT

The bq27350 can measure temperature via the on-chip temperature sensor or via the TS input depending on the setting of the *[TEMPS]* bit *PackConfiguration()*. The bit is set by using the *PackConfiguration()* function, described in the section entitled *EXTENDED COMMAND SUMMARY*.

Temperature measurements are made by calling the *Temperature()* function (see *STANDARD COMMANDS* for specific information).

When an external thermistor input is used, TOUT (pin 7) is used to power the thermistor and TS (pin 3) to measure the thermistor voltage. The bq27350 then correlates the voltage to temperature assuming the thermistor is a Semitec 103AT or similar device.

5.4 OVER-TEMPERATURE INDICATION

The bq27350 can set safety flag indications based on measure temperature both in charge and discharge states.

Over-Temperature: Charge

If during charging, *Temperature()* exceeds the threshold of **OT Chg** for a period of **OT Chg Time** and *AverageCurrent()* > **Chg Current Threshold**, then the *[OTC]* bit of *Flags()* is set. Note: if **OT Chg Time** = 0 then feature is completely disabled.

When *Temperature()* falls below **OT Chg Recovery**, the *[OTC]* of *Flags()* is reset.

Over-Temperature: Discharge

If, during discharging, *Temperature()* exceeds the threshold of **OT Dsg** for a period of **OT Dsg Time**, and *AverageCurrent()* ≤ **-Dsg Current Threshold**, then the *[OTD]* bit of *Flags()* is set. Note: if **OT Dsg Time** = 0 then feature is completely disabled.

When *Temperature()* falls below **OT Dsg Recovery**, the *[OTD]* bit of *Flags()* is reset.

5.5 CHARGING AND CHARGE TERMINATION INDICATION

For proper bq27350 operation, the cell charging voltage must be specified by the user. The default value for this variable is **Charging Voltage** = 4200mV.

The bq27350 detects charge termination when (1) during 2 consecutive periods of **Current Taper Window**, the *AverageCurrent()* is < **Taper Current** and (2) during the same periods, the accumulated change in capacity > 0.25mAh / **Taper Current Window** and (3) *Voltage()* > **Charging Voltage - Charging Taper Voltage**. When this occurs, the *[FC]* bit of *Flags()* is set and *[CHG]* bit is cleared. Also, if the *[RMFCC]* bit of **Pack Configuration** is set, then *RemainingCapacity()* is set equal to *FullChargeCapacity()*

5.6 POWER MODES

The bq27350 has four power modes: NORMAL, SLEEP, HIBERNATE, and SHUTDOWN (in descending

order of power consumption). In NORMAL mode, the bq27350 is fully powered and can execute any allowable task. In SLEEP mode the gas gauge exists in a reduced-power state, periodically taking measurements and performing calculations. In HIBERNATE mode the gas gauge is in its lowest power state, only to be woken by communications activity or an increase in the magnitude of battery current. Finally in SHUTDOWN mode, all bq27350 circuits are turned off and power is removed from the device; the IC can be restarted by reapplying sufficient voltage to the device.

The relationship between these modes is shown in Figure 5-1. Details are described in the sections that follow.

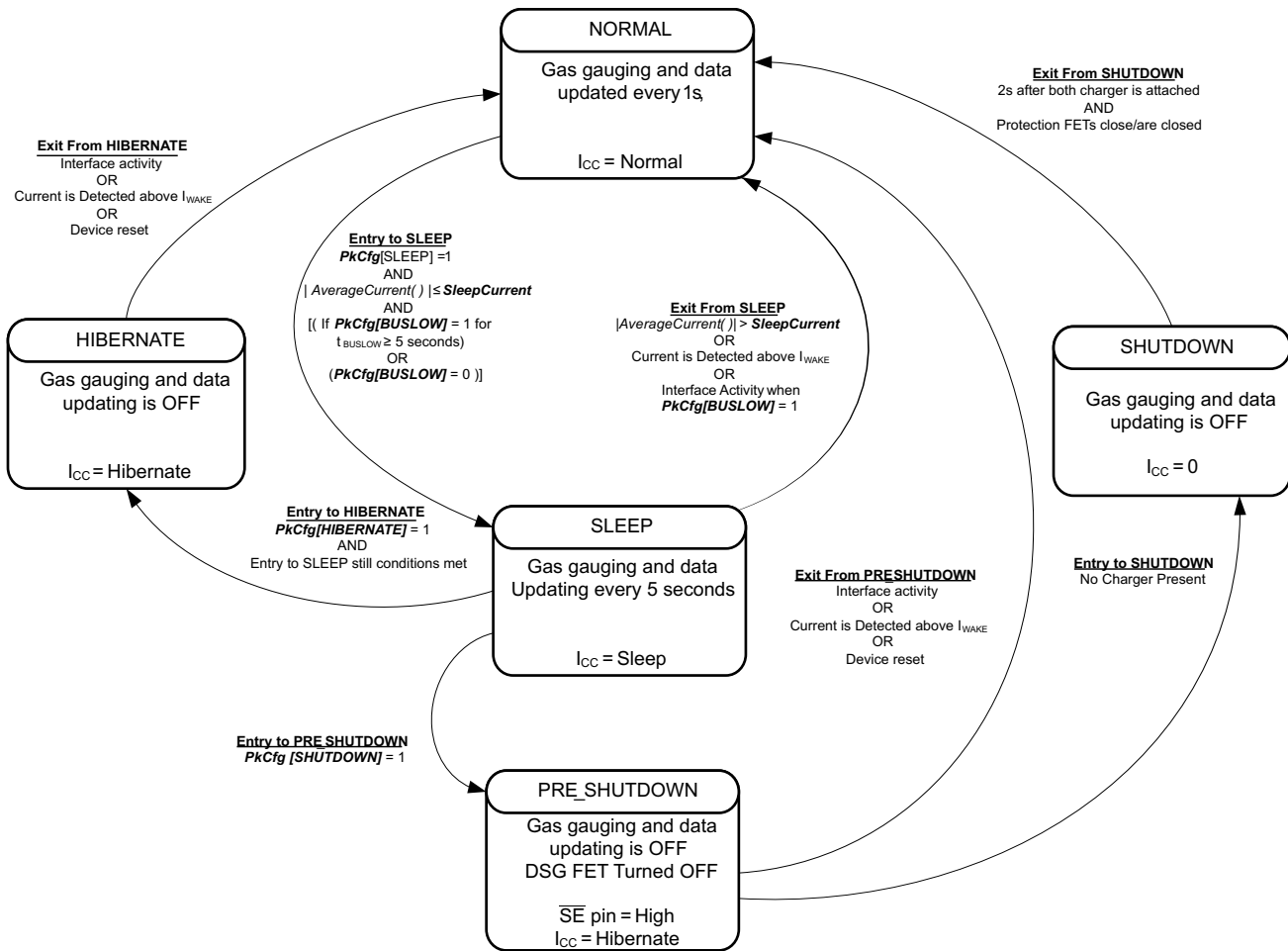

Figure 5-1. Power Mode Diagram

5.6.1 NORMAL MODE

The gas gauge is in NORMAL mode when not in any other power mode. During this mode, *AverageCurrent()*, *Voltage()* and *Temperature()* measurements are taken, and the interface data set is updated. Decisions to change states are also made. This mode is exited by activating a different power mode.

5.6.2 SLEEP MODE

SLEEP mode is entered when (1) *AverageCurrent()* is below a programmable level **Sleep Current** and (2) if the [BUSLOW] bit of *Pack Configuration()* is set and the data bus (both SCL and SDA low pins) is low for 5s. [SLEEP] bit of *Control Status()* is set when the bq27350 enters SLEEP mode. Once entry to SLEEP has been qualified, but prior to entry to sleep mode, the bq27350 performs an ADC autocalibration

to minimize offset. Entry into SLEEP mode can be disabled by setting the *[SLEEP]* bit of *Pack Configuration()*, where "0" = disabled and "1" = enabled. During SLEEP mode, the bq27350 periodically wakes to take data measurements and update the data set, after which it then returns directly to SLEEP. The bq27350 exits SLEEP if any entry condition is broken, a change in protection status occurs, or a current in excess of I_{WAKE} through R_{SENSE} is detected.

5.6.3 HIBERNATE MODE

To enter HIBERNATE mode, the *[HIBERNATE]* bit of *PackConfiguration()* needs to be set when the device enters SLEEP mode. The HIBERNATE mode is exited if (1) communication is detected, (2) a device reset occurs, or (3) if current through R_{SENSE} is above I_{WAKE} . If the *Pack Configuration [HIBERNATE]* bit is cleared, the bq27350 will not enter HIBERNATE mode. Upon exiting HIBERNATE mode, the device is returned to NORMAL mode.

5.6.4 SHUTDOWN MODE

SHUTDOWN mode requires the use of an external LDO with an enable feature (active low). To enter SHUTDOWN, the *PackConfiguration()* *[SHUTDOWN]* bit needs to be set when the bq27350 enters HIBERNATE. A charger must not be present and the DSG FET of protector must be turned OFF. If the *[SHUTDOWN]* bit of *PackConfiguration()* is set, the bq27350 raise its \overline{SE} pin high on entry into HIBERNATE. This action, in conjunction with the deactivation of the DSG FET (low-side protector implementation), shuts down the LDO and, hence, the bq27350. The LDO recovers when a charger is applied for more than 2s.

5.7 POWER CONTROL

5.7.1 RESET FUNCTIONS

When the bq27350 detects either a hardware or software reset (\overline{MRST} pin driven low or the *[RESET]* bit of *Control()* initiated, respectively), it determines the type of reset and increments the corresponding counter. This information is accessible by issuing the command *Control()* function with the RESET_DATA subcommand.

As shown in [Figure 5-2](#) if a partial reset was detected, a RAM checksum is generated and compared against the previously stored checksum. If the checksum values do not match, the RAM is reinitialized (a "Full Reset"). The stored checksum is updated every time RAM is altered.

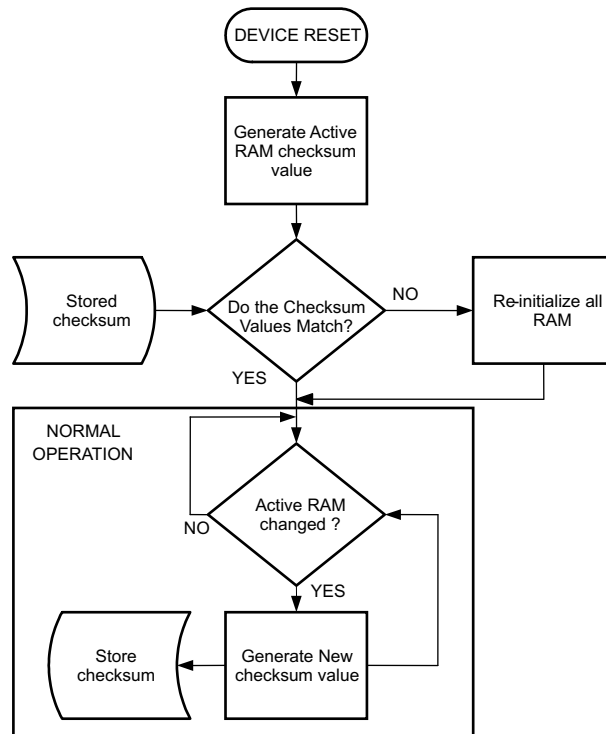
Figure 5-2. Partial Reset Flow Diagram

5.7.2 WAKE-UP COMPARATOR

The wake up comparator is used to indicate a change in cell current while the bq27350 is in either Sleep or Hibernate modes. *PackConfiguration()* uses bits *[RSNS1-RSNS0]* to set the sense resistor selection. *PackConfiguration()* uses the *[IWAKE]* bit to select one of two possible voltage threshold ranges for the given sense resistor selection. An internal interrupt is generated when the threshold is breached in either charge or discharge directions. A setting of 0x00 of RSNS1..0 disables this feature.

Table 5-3. I_{WAKE} Threshold Settings⁽¹⁾

RSNS1	RSNS0	IWAKE	Vth(SRP-SRN)
0	0	0	Disabled
0	0	1	Disabled
0	1	0	+1.25 mV or –1.25 mV
0	1	1	+2.5 mV or –2.5 mV
1	0	0	+2.5 mV or –2.5 mV
1	0	1	+5 mV or –5 mV
1	1	0	+5 mV or –5 mV
1	1	1	+10 mV or –10 mV

(1) The actual resistance value vs. the setting of the sense resistor is not important just the actual voltage threshold when calculating the configuration.

5.7.3 FLASH UPDATES

Data Flash can only be updated if *Voltage()* ≥ **Flash Update OK Voltage**. Flash programming current can cause an increase in LDO dropout. The value of **Flash Update OK Voltage** should be selected such that the bq27350 Vcc voltage does not fall below its minimum of 2.4V during Flash write operations. For the TPS71525 LDO shown in the Reference Schematic, the default value of 2800mV is appropriate.

5.8 AUTOCALIBRATION

The bq27350 provides an autocalibration feature that will measure the voltage offset error across SRP and SRN from time-to-time as operating conditions change. It subtracts the resulting offset error from normal sense resistor voltage, V_{sr} , for maximum measurement accuracy.

The gas gauge performs a single offset calibration when (1) the interface lines stay low for a minimum of **Bus Low Time** and (2) $V_{sr} > \text{Deadband}$.

The gas gauge also performs a single offset when (1) the condition of $\text{AverageCurrent}() \leq \text{Autocal Min Current}$ and (2) {voltage change since last offset calibration $\geq \text{Delta Voltage}$ } or {temperature change since last offset calibration is greater than Delta Temperature for $\geq \text{Autocal Time}$ }.

Capacity and current measurements should continue at the last measured rate during the offset calibration when these measurements cannot be performed. If the battery voltage drops more than **Cal Abort** during the offset calibration, the load current has likely increased considerably; hence, the offset calibration will be aborted.

6 COMMUNICATIONS

The bq27350 uses I²C communications identical to the bq27200, and interfaces directly with TI-OMAP and other standard I²C-master devices.

The bq27350 also uses an SDQ interface to communicate with security products, such as the bq26100. The bq27350 is only acting as a format translator between I²C and SDQ.

6.1 I²C INTERFACE

The bq27350 supports the standard I²C read, incremental read, quick read, one-byte write, and incremental write functions. The 7-bit device address (ADDR) is the most significant 7 bits of the hex address and is fixed as 0001011. The 8-bit device address is therefore 0x16 or 0x17 for write or read, respectively.

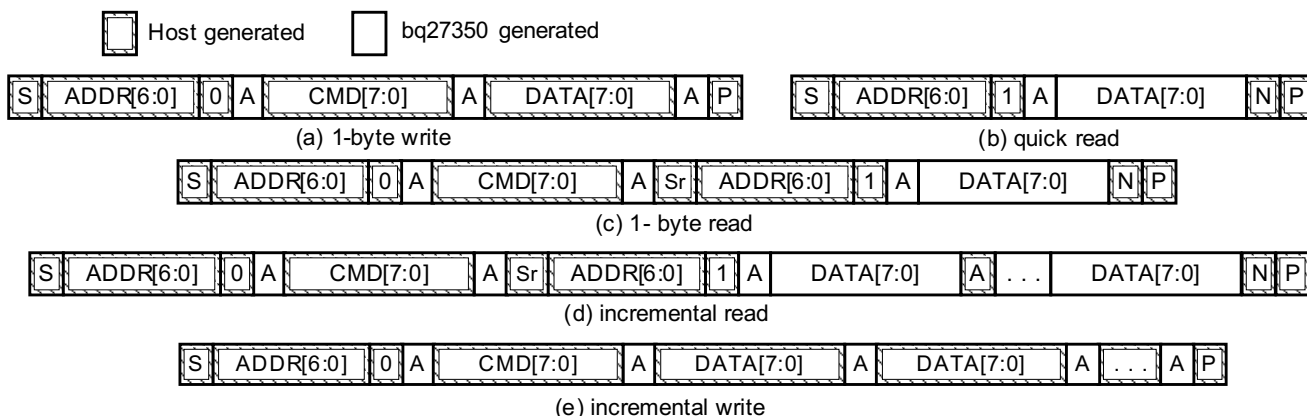

(S = Start, Sr = Repeated Start, A = Acknowledge, N = No Acknowledge, and P = Stop).

Figure 6-1. Supported I²C Formats

The “quick read” returns data at the address indicated by the address pointer. The address pointer, a register internal to the I²C communication engine, increments whenever data is acknowledged by the bq27350 or the I²C master. “Quick writes” function in the same manner and are a convenient means of sending multiple bytes to consecutive command locations (such as two-byte commands that require two bytes of data).

The following command sequences are not supported:

Attempt to write a read-only address (NACK after data sent by master):

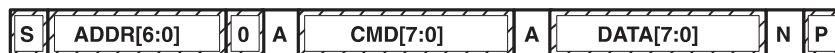

Attempt to read an address above 0x6A (NACK command):



The I²C engine releases both SDA and SCL if the I²C bus is held low for $t_{(BUSERR)}$. If the bq27350 was holding the lines, releasing them frees the master to drive the lines. If an external condition is holding either of the lines low, the I²C engine enters low-power sleep mode.

6.2 AUTHENTICATION

The bq27350 can act as a SHA-1/HMAC authentication slave, either by using its internal engine or by using an external bq26100 (contains secure memory). In both implementations, sending a 160-bit SHA-1 challenge message to the bq27350 will cause the IC to return a 160-bit digest, based upon the challenge message and hidden plain-text authentication keys. When this digest matches an identical one, generated by a host or dedicated authentication master operating on the same challenge message and using the same plain text keys, the authentication process is successful.

The bq27350 contains a default plain-text authentication key of 0x0123456789ABCDEFDCBA987654321. If using the bq27350's internal authentication engine, the default key can be used for development purposes, but should be changed to a secret key and the part immediately sealed, before putting a pack into operation. If using the a bq26100 for external authentication, the key must be changed to 16 bytes of "0x00".

6.2.1 KEY PROGRAMMING

When the bq27350's SHA-1/HMAC internal engine is used, authentication keys are stored as plain-text in memory. A plain-text authentication key can only be written to the bq27350 while the IC is in UNSEALED mode. Once the IC is UNSEALED, a 0x00 is written to *BlockDataControl()* to enable the authentication data commands. Next, subclass ID and offset are specified by writing 0x70 and 0x00 to *DataFlashClass()* and *DataFlashBlock()*, respectively. The bq27350 is now prepared to receive the 16-byte plain-text key, which must begin at command location 0x4C. The key is accepted once a successful checksum has been written to *BlockDataChecksum()*, FOR THE ENTIRE 32-BYTE BLOCK (0x40 through 0x5f), NOT JUST THE 16-BYTE KEY.

When using an external bq26100 authentication IC, authentication keys are stored within the bq26100's secure memory. The bq26100 uses a split-key system of two 64-bit keys, instead of a single 128-bit key. Details on programming these keys can be found in the [bq26100 data sheet](#).

6.2.2 EXECUTING AN AUTHENTICATION QUERY

To execute an authentication query in UNSEALED mode, a host must first write 0x01 to the *BlockDataControl()* command, to enable the authentication data commands. If in SEALED mode, 0x00 must be written to *DataFlashBlock()*, instead. Next, the host writes a 20-byte authentication challenge to the *AuthenticateData()* address locations (0x40 through 0x53). After a valid checksum for the challenge is written to *AuthenticateChecksum()*, the bq27350 uses the challenge to perform its own the SHA-1/HMAC computation, in conjunction with its programmed keys. The resulting digest is written to *AuthenticateData()*, overwriting the pre-existing challenge. The host may then read this response and compare it against the result created by its own parallel computation.

7 REFERENCE SCHEMATIC

The reference circuit on the next page shows an I²C communication implementation of the bq27350. D1 and associated resistors provide added protection against ESD appearing on the communication lines. Capacitors C4/C8 and C15/C16 are also used for ESD protection and are paired together for increased voltage handling ability and redundancy protection, should one capacitor fail in a shorted state.

Optional circuits for external authentication, using the bq26100 (U1), and external temperature measurements (R12, R14, and C10) are also shown.

Common-mode and differential filters (R7-19 and C12-14) remove noise at input of the coulomb counter input. U4, Q4, and associated passives form the Li+ cell protector, while U3, C5, and C9 comprise the LDO IC and its input/output capacitors. R5 and C7 provide a delayed "power good" signal to the $\overline{\text{MRST}}$ input.

Q3, R13, and D2 act as an LDO disable circuit (LDO is off when PACK- and $\overline{\text{SE}}$ pin are both "high"). Finally, Q1, Q2, R1, R2 and R4 form a precision voltage divider that reduces cell voltage to levels suitable for the bq27350.

Revision History

NOTE: Page numbers for previous revisions may differ from page numbers in the current version.

Changes from A Revision (April 2008) to B Revision	Page
--	------

- | | |
|---|-------------------|
| • Changed Li-ion to Li-Ion/Li-Polymer in 3 places | 1 |
|---|-------------------|
-

PACKAGING INFORMATION

Orderable Device	Status (1)	Package Type	Package Drawing	Pins	Package Qty	Eco Plan (2)	Lead finish/ Ball material (6)	MSL Peak Temp (3)	Op Temp (°C)	Device Marking (4/5)	Samples
BQ27350PW	ACTIVE	TSSOP	PW	20	70	RoHS & Green	Call TI NIPDAU	Level-1-260C-UNLIM	-40 to 85	27350PW	Samples
BQ27350PWR	ACTIVE	TSSOP	PW	20	2000	RoHS & Green	Call TI NIPDAU	Level-1-260C-UNLIM	-40 to 85	27350PW	Samples

(1) The marketing status values are defined as follows:

ACTIVE: Product device recommended for new designs.

LIFEBUY: TI has announced that the device will be discontinued, and a lifetime-buy period is in effect.

NRND: Not recommended for new designs. Device is in production to support existing customers, but TI does not recommend using this part in a new design.

PREVIEW: Device has been announced but is not in production. Samples may or may not be available.

OBSOLETE: TI has discontinued the production of the device.

(2) **RoHS:** TI defines "RoHS" to mean semiconductor products that are compliant with the current EU RoHS requirements for all 10 RoHS substances, including the requirement that RoHS substance do not exceed 0.1% by weight in homogeneous materials. Where designed to be soldered at high temperatures, "RoHS" products are suitable for use in specified lead-free processes. TI may reference these types of products as "Pb-Free".

RoHS Exempt: TI defines "RoHS Exempt" to mean products that contain lead but are compliant with EU RoHS pursuant to a specific EU RoHS exemption.

Green: TI defines "Green" to mean the content of Chlorine (Cl) and Bromine (Br) based flame retardants meet JS709B low halogen requirements of <=1000ppm threshold. Antimony trioxide based flame retardants must also meet the <=1000ppm threshold requirement.

(3) MSL, Peak Temp. - The Moisture Sensitivity Level rating according to the JEDEC industry standard classifications, and peak solder temperature.

(4) There may be additional marking, which relates to the logo, the lot trace code information, or the environmental category on the device.

(5) Multiple Device Markings will be inside parentheses. Only one Device Marking contained in parentheses and separated by a "~" will appear on a device. If a line is indented then it is a continuation of the previous line and the two combined represent the entire Device Marking for that device.

(6) Lead finish/Ball material - Orderable Devices may have multiple material finish options. Finish options are separated by a vertical ruled line. Lead finish/Ball material values may wrap to two lines if the finish value exceeds the maximum column width.

Important Information and Disclaimer:The information provided on this page represents TI's knowledge and belief as of the date that it is provided. TI bases its knowledge and belief on information provided by third parties, and makes no representation or warranty as to the accuracy of such information. Efforts are underway to better integrate information from third parties. TI has taken and continues to take reasonable steps to provide representative and accurate information but may not have conducted destructive testing or chemical analysis on incoming materials and chemicals. TI and TI suppliers consider certain information to be proprietary, and thus CAS numbers and other limited information may not be available for release.

In no event shall TI's liability arising out of such information exceed the total purchase price of the TI part(s) at issue in this document sold by TI to Customer on an annual basis.

TUBE

*All dimensions are nominal

Device	Package Name	Package Type	Pins	SPQ	L (mm)	W (mm)	T (μm)	B (mm)
BQ27350PW	PW	TSSOP	20	70	530	10.2	3600	3.5

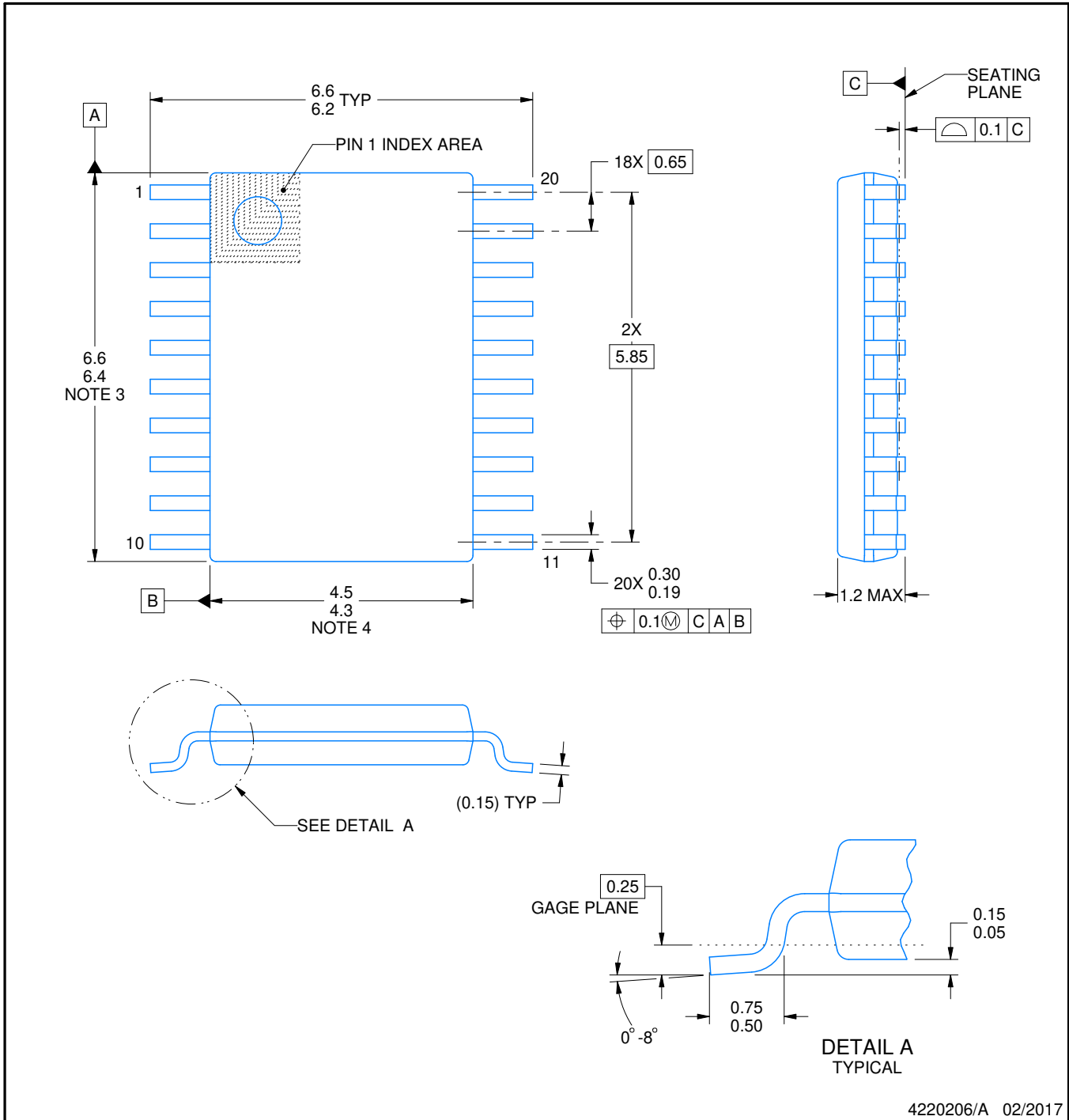

4220206/A 02/2017

NOTES:

1. All linear dimensions are in millimeters. Any dimensions in parenthesis are for reference only. Dimensioning and tolerancing per ASME Y14.5M.
2. This drawing is subject to change without notice.
3. This dimension does not include mold flash, protrusions, or gate burrs. Mold flash, protrusions, or gate burrs shall not exceed 0.15 mm per side.
4. This dimension does not include interlead flash. Interlead flash shall not exceed 0.25 mm per side.
5. Reference JEDEC registration MO-153.

EXAMPLE BOARD LAYOUT

PW0020A

TSSOP - 1.2 mm max height

SMALL OUTLINE PACKAGE

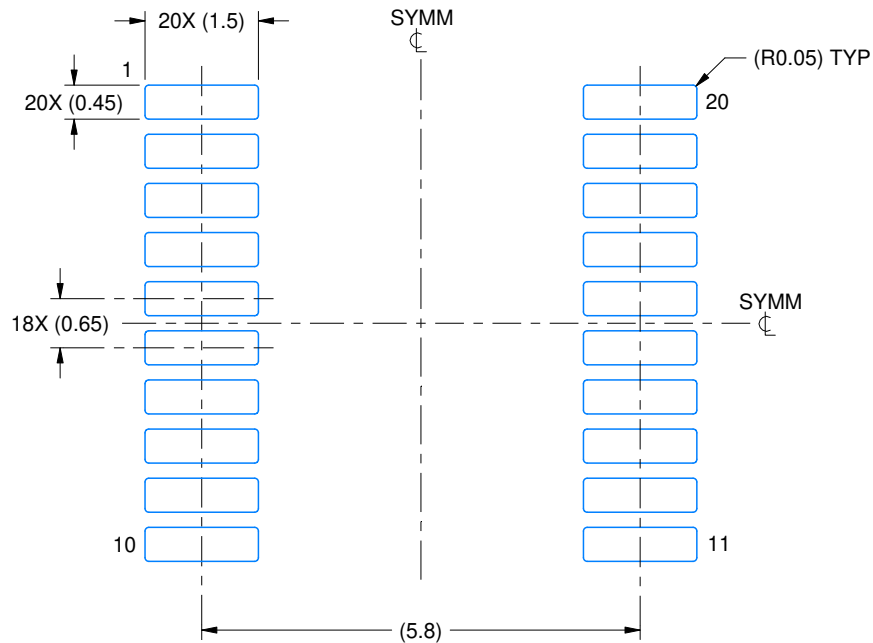

LAND PATTERN EXAMPLE
EXPOSED METAL SHOWN
SCALE: 10X



4220206/A 02/2017

NOTES: (continued)

- 6. Publication IPC-7351 may have alternate designs.
- 7. Solder mask tolerances between and around signal pads can vary based on board fabrication site.

EXAMPLE STENCIL DESIGN

PW0020A

TSSOP - 1.2 mm max height

SMALL OUTLINE PACKAGE

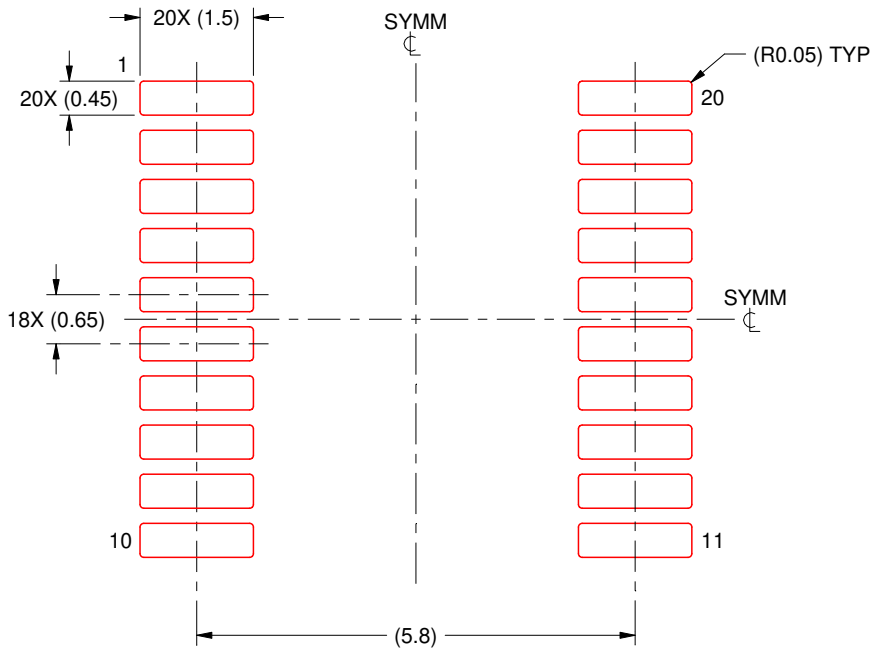

SOLDER PASTE EXAMPLE
BASED ON 0.125 mm THICK STENCIL
SCALE: 10X

4220206/A 02/2017

NOTES: (continued)

8. Laser cutting apertures with trapezoidal walls and rounded corners may offer better paste release. IPC-7525 may have alternate design recommendations.
9. Board assembly site may have different recommendations for stencil design.

PW (R-PDSO-G20)

PLASTIC SMALL OUTLINE

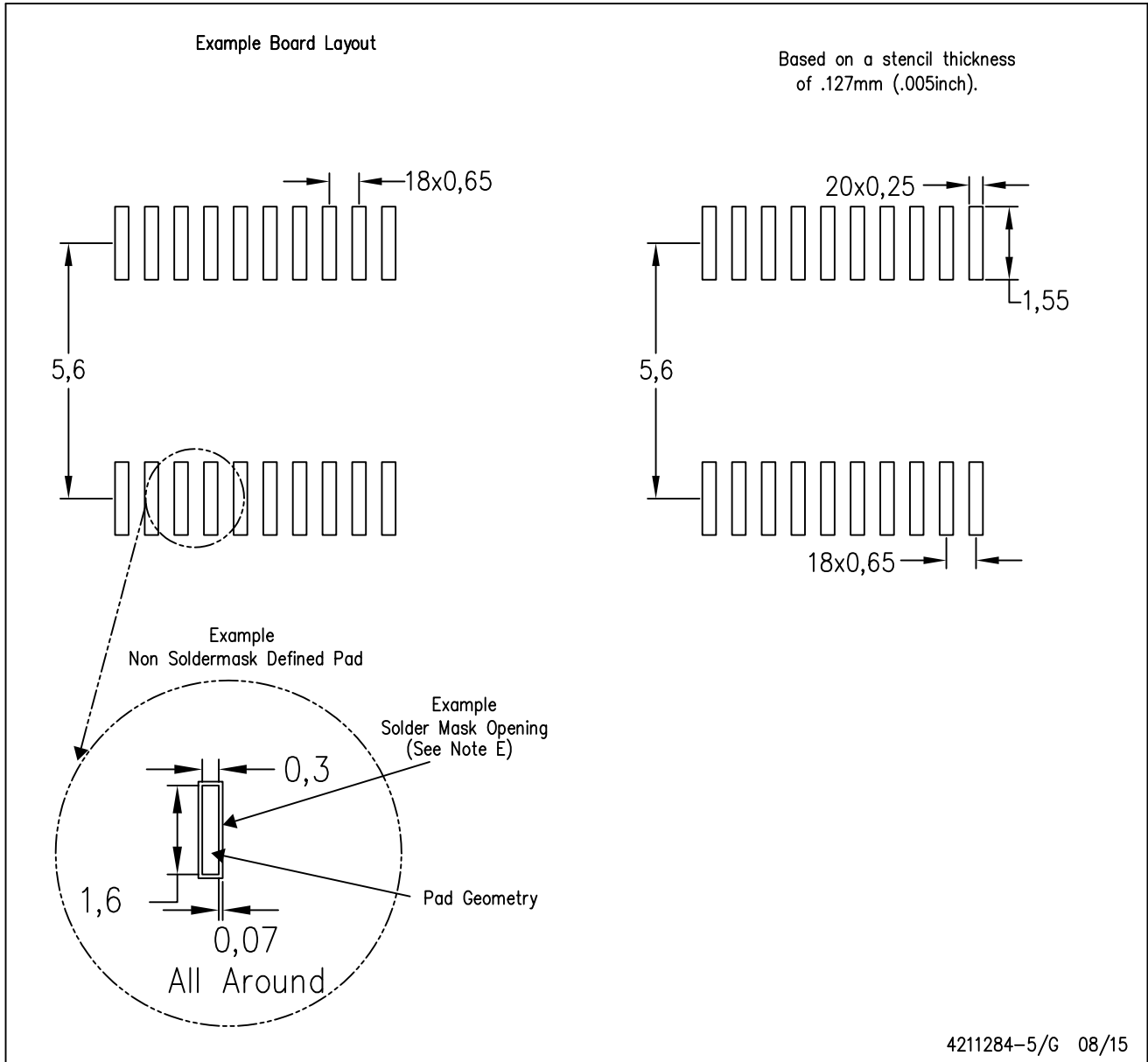

- NOTES:
- A. All linear dimensions are in millimeters.
 - B. This drawing is subject to change without notice.
 - C. Publication IPC-7351 is recommended for alternate design.
 - D. Laser cutting apertures with trapezoidal walls and also rounding corners will offer better paste release. Customers should contact their board assembly site for stencil design recommendations. Refer to IPC-7525 for other stencil recommendations.
 - E. Customers should contact their board fabrication site for solder mask tolerances between and around signal pads.

IMPORTANT NOTICE AND DISCLAIMER

TI PROVIDES TECHNICAL AND RELIABILITY DATA (INCLUDING DATA SHEETS), DESIGN RESOURCES (INCLUDING REFERENCE DESIGNS), APPLICATION OR OTHER DESIGN ADVICE, WEB TOOLS, SAFETY INFORMATION, AND OTHER RESOURCES "AS IS" AND WITH ALL FAULTS, AND DISCLAIMS ALL WARRANTIES, EXPRESS AND IMPLIED, INCLUDING WITHOUT LIMITATION ANY IMPLIED WARRANTIES OF MERCHANTABILITY, FITNESS FOR A PARTICULAR PURPOSE OR NON-INFRINGEMENT OF THIRD PARTY INTELLECTUAL PROPERTY RIGHTS.

These resources are intended for skilled developers designing with TI products. You are solely responsible for (1) selecting the appropriate TI products for your application, (2) designing, validating and testing your application, and (3) ensuring your application meets applicable standards, and any other safety, security, regulatory or other requirements.

These resources are subject to change without notice. TI grants you permission to use these resources only for development of an application that uses the TI products described in the resource. Other reproduction and display of these resources is prohibited. No license is granted to any other TI intellectual property right or to any third party intellectual property right. TI disclaims responsibility for, and you will fully indemnify TI and its representatives against, any claims, damages, costs, losses, and liabilities arising out of your use of these resources.

TI's products are provided subject to [TI's Terms of Sale](#) or other applicable terms available either on [ti.com](#) or provided in conjunction with such TI products. TI's provision of these resources does not expand or otherwise alter TI's applicable warranties or warranty disclaimers for TI products.

TI objects to and rejects any additional or different terms you may have proposed.

Mailing Address: Texas Instruments, Post Office Box 655303, Dallas, Texas 75265
Copyright © 2022, Texas Instruments Incorporated