

LOC		DIST		REVISIONS				DATE	APPD
ZONE	LTR	DESCRIPTION	DATE	APPD					
AF	50	P	F	F	REVISED PER 063A-0456-01	18SEP01	MF/KR		

- 1 CONTINUOUS STRIP ON REELS WITH TERMINALS LOCATED ON 8.38±0.08 [.330±.003] CENTERS
- 2 SLOT ACCEPTS 0.18-0.23mm [#33-#31] AWG COPPER MAGNET WIRE. TWO WIRES OF THE SAME SIZE MAX PER SLOT
- 3 IDENTIFICATION NUMBER 4 FOR THE MAGNET WIRE SLOT SIZE
- 4 0.25 [.010] MAX CARRIER CUT-OFF TABS.
- 5 PREPRODUCTION - F.A.S.R. REQUIRED.

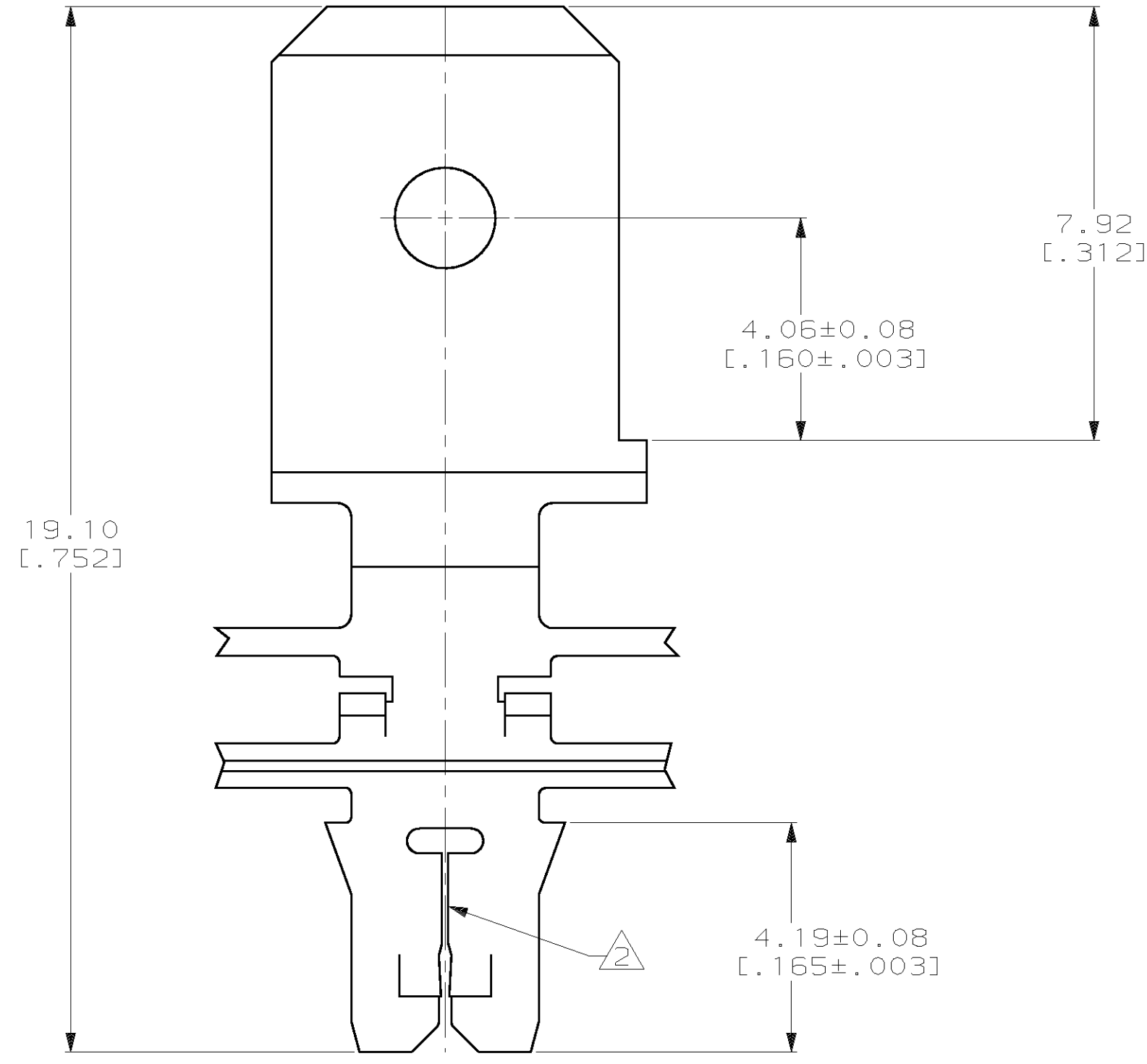
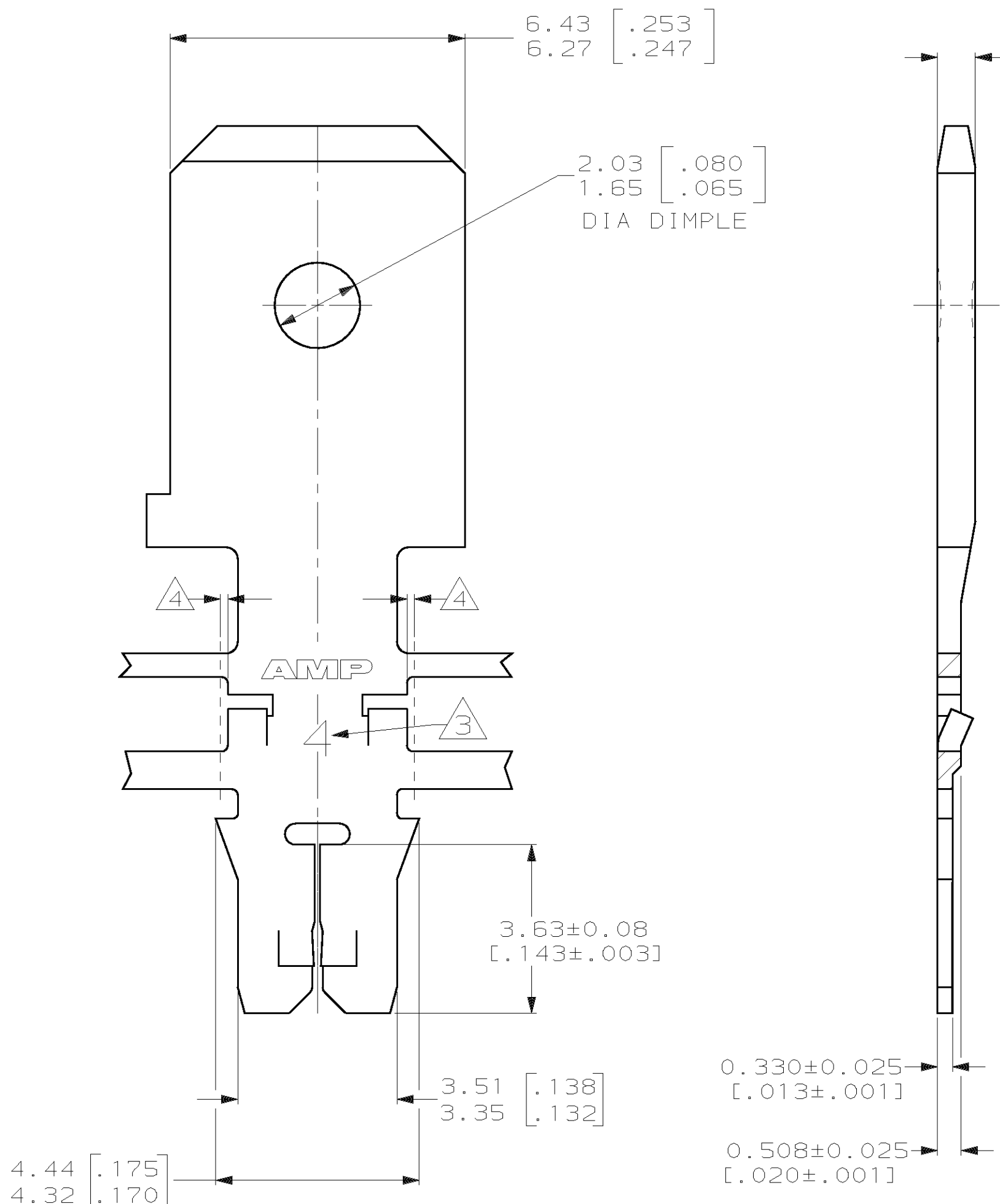

082 PRE-MILLED BRASS	5	63744-2
4M PRE-MILLED BRASS		63744-1
MATERIAL		PART NO

DO NOT SCALE PRINT. UNLESS SPECIFIED DIMENSIONS IN mm [INCHES] TOLERANCES ON : 2 PLC DEC ± 0.13 [.005] 3 PLC DEC ± - ANGLES ± -	DR 9-1-93 L.A.MAYER	AMP Incorporated Harrisburg, PA 17105-3608	
	CHK 9-1-93 M.S. FEHER		
MATERIAL SEE TABLE	APPD 9-1-93 A.HUNT III	NAME TAB, 6.35 [.250] FASTON™ MAG-MATE™ Slim Line	
	APPD 9-1-93 T.L.SHUTTER	DRAWING NO C=63744	
FINISH 0.002032 [.000080] MIN TIN	PRODUCT SPEC 108-1484	SIZE C	CAGE CODE 00779
	APPLICATION SPEC 114-2140	SCALE 10:1	SHEET 1 OF 1
THIS DRAWING IS A CONTROLLED DOCUMENT FOR AMP INCORPORATED. IT IS SUBJECT TO CHANGE AND THE CONTROLLING ENGINEERING ORGANIZATION SHOULD BE CONTACTED FOR THE LATEST REVISION.	WEIGHT -	CUSTOMER DRAWING	