

LOC	DIST	REVISIONS					
		P.	LTN	DESCRIPTION	DATE	DWN	APVD
		C		ECO-13-005468	03APR2013	JM	RA
		D		REV; ECO-15-003155	19MAY2015	GG	RA

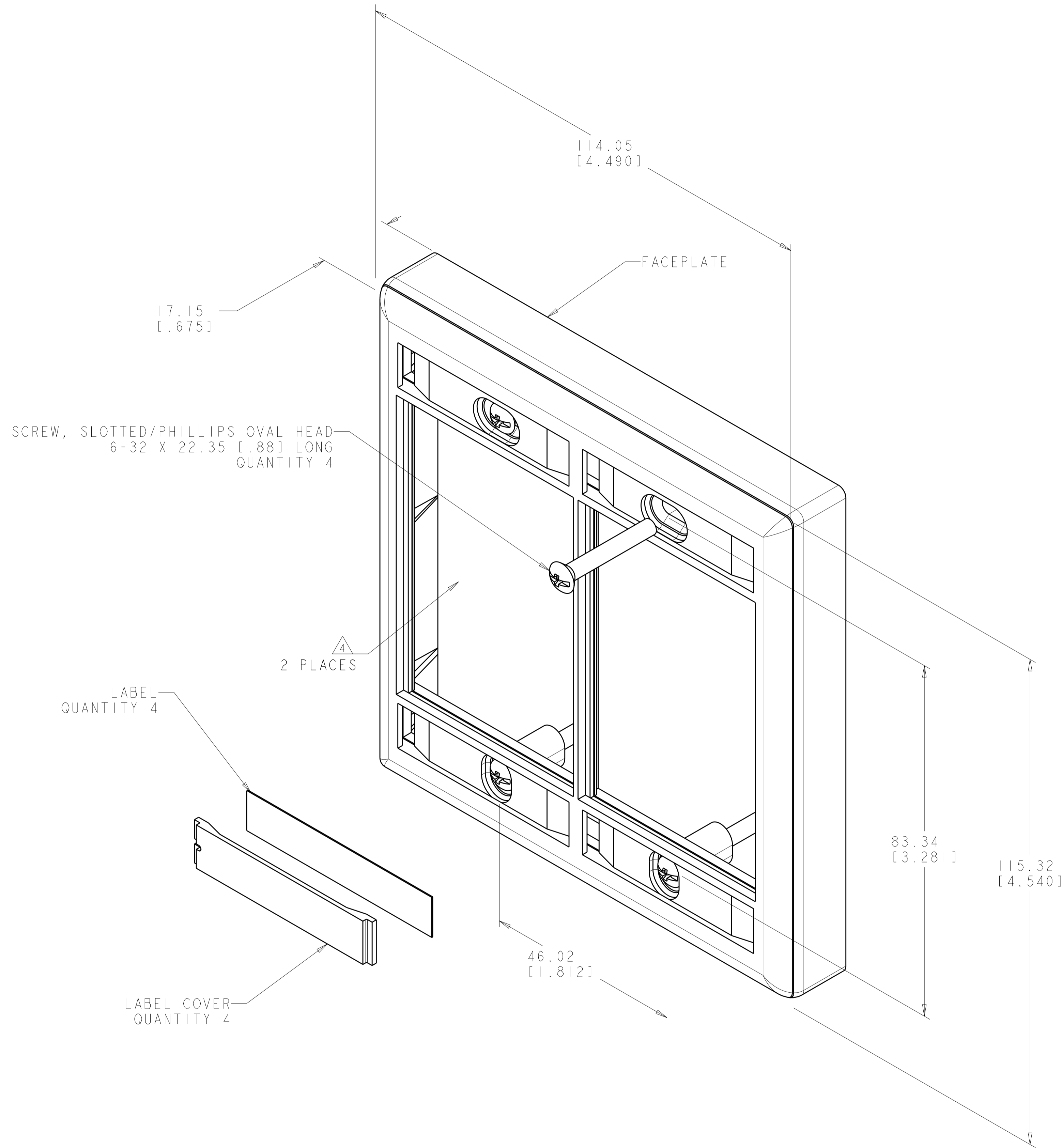

- △ MATERIAL: FACEPLATE - POLYCARBONATE MOLDING COMPOUND.
 SEE TABLE FOR COLOR.
 LABEL COVERS - POLYCARBONATE MOLDING COMPOUND.
 LABELS - WHITE INDEX PAPER.
 SCREWS - ZINC PLATED CARBON STEEL.
- 2. THIS KIT SHIPPED NOT ASSEMBLED.
- △ DIMENSIONS ARE NOMINAL.
- △ OPENING ACCEPTS THREE 1 UNIT OR TWO 1.5 UNIT SL SERIES MODULES.

ALPINE WHITE	I-1479486-3
LIGHT ALMOND	1479486-1
COLOR	PART NUMBER

THIS DRAWING IS A CONTROLLED DOCUMENT.		DWN	G. GARRETT	22APR03
DIMENSIONS: MM [INCHES]		CHK	G. BOWMAN	22APR03
TOLERANCES UNLESS OTHERWISE SPECIFIED:		APVD	G. BOWMAN	22APR03
0 PLC	±	NAME		
1 PLC	±	PRODUCT SPEC		
2 PLC	±	KIT, FACEPLATE		
3 PLC	±	DOUBLE GANG, SL SERIES, STANDARD		
4 PLC	±	APPLICATION SPEC		
ANGLES	±	SIZE	CAGE CODE	DRAWING NO
FINISH	±	A1	00779	1479486
MATERIAL		WEIGHT	RESTRICTED TO	
Customer Drawing			-	
SCALE		2:1	SHEET	1 OF 1
REV				D