

# 2-Axis Magnetic Sensor Circuit HMC6042

*Advanced Information*

The Honeywell HMC6042 is a surface mount multi-chip module designed for low field magnetic sensing such as low cost compassing and magnetometry. The HMC6042 includes our state of the art 1042 series magneto-resistive sensors plus a precision mixed signal ASIC containing three sensor amplifiers and a compatible set/reset strap driver circuit for 2.4 to 3.6 volt operation. The ASIC plus sensors are surface mount packaged in a 3.6 by 5.0 by 1.0mm LCC that can be used stand alone for very low cost 2-axis compasses, or with the HMC1041Z to complete the magnetic sensor portion of a 3-axis, tilt compensated compass. Applications for the HMC6042 include Consumer Electronic Compassing and Magnetometry.

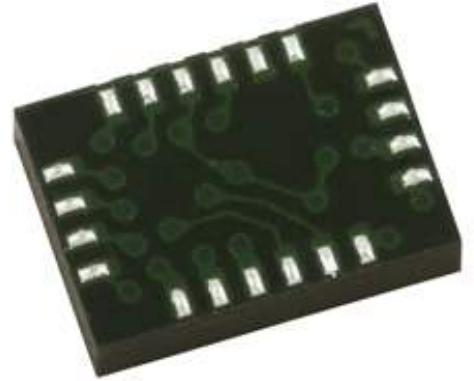

The HMC6042 utilizes Honeywell's Anisotropic Magneto-resistive (AMR) technology that provides advantages over other magnetic sensor technologies. The sensors feature precision in-axis sensitivity and linearity, solid-state construction with very low cross-axis sensitivity designed to measure both direction and magnitude of Earth's magnetic fields, from tens of micro-gauss to 6 gauss. Honeywell's Magnetic Sensors are among the most sensitive and reliable low-field sensors in the industry.

Honeywell continues to maintain product excellence and performance by introducing innovative solid-state magnetic sensor solutions. These are highly reliable, top performance products that are delivered when promised. Honeywell's magnetic sensor solutions provide real solutions you can count on.

## FEATURES

- ▶ 2-Axis Magneto-resistive Sensor and ASIC in a Single Package
- ▶ Low Cost
- ▶ 5 x 3.6 x 1.0mm LCC Surface Mount Package
- ▶ Low Voltage Operations (2.4 to 3.6V)
- ▶ Built-In Set/Reset Drive Circuit
- ▶ Signal Processing Flexibility
- ▶ Lead Free Package Construction
- ▶ Wide Magnetic Field Range (+/-6 Oe)
- ▶ Available in Tape & Reel Packaging

## BENEFITS

- ▶ Small Size for Highly Integrated Products. Just Add a Micro-Controller Interface with ADC, Plus Two External SMT Capacitors
- ▶ Designed for High Volume, Cost Sensitive OEM Designs
- ▶ Easy to Assemble & Compatible with High Speed SMT Assembly
- ▶ Compatible for Battery Powered Applications
- ▶ Single Logic Input for Degaussing, Thermal Drift Compensation
- ▶ Feedback Pins for Gain and Bandwidth Shaping
- ▶ Complies with Current Environmental Standards
- ▶ Sensors Can Be Used in Strong Magnetic Field Environments
- ▶ High Volume OEM Assembly

# HMC6042

## SPECIFICATIONS

Characteristics	Conditions*	Min	Typ	Max	Units
<b>System</b>					
Sensitivity	Open Loop Gain, After Set/Reset Pulses	175		275	mV/V/gauss
Zero Field Offset	VDD1 = 3.0 volts	0.75	1.5	2.25	volts
Magnetic Field Range	Full Scale	±1		±2	gauss
<b>Power Supply</b>					
Supply Voltage	VDD1, VDD2 Referenced to GND	2.4	3.0	3.6	Volts
Current	Bridge Current = 0.9mA/volt per axis Continuous (VDD1) Peak (0.5msec) (VDD1 + VDD2)	5.2		7.0 25	mA
<b>Magnetic sensors</b>					
Field Range	Full scale (FS) – total applied field	-6		+6	gauss
Sensitivity	After Set/Reset Pulses	0.8	1.0	1.25	mV/V/gauss
Resolution	1 kHz bandwidth, VDD1 = 3.0 volts		0.12		milli-gauss (RMS)
Bridge Offset	Offset = (OUT+) – (OUT-) Field = 0 gauss after Set pulse	-1.25	±0.5	+1.25	mV/V
Cross-Axis Sensitivity	Cross field = 0.5 gauss, Happlied = ±3 gauss		±0.2%		%FS/gauss
Disturbing Field	Sensitivity starts to degrade. Use S/R pulse to restore sensitivity.			20	gauss
Max. Exposed Field	No perming effect on zero reading			10000	gauss
Sensitivity Tempco	T <sub>A</sub> = -40 to 125°C, V <sub>bridge</sub> = 5V	-3500	-3100	-2000	ppm/°C
Bridge Offset Tempco	T <sub>A</sub> = -40 to 125°C, No Set/Reset T <sub>A</sub> = -40 to 125°C, With Set/Reset		±500 ±10		ppm/°C
Bridge Ohmic Tempco	VDD1 = 3.0V, T <sub>A</sub> = -40 to 125°C	2100	2500	2900	ppm/°C
Linearity Error	Best fit straight line ± 1 gauss ± 3 gauss ± 6 gauss		0.17 0.42 0.80		%FS
Hysteresis Error	3 sweeps across ±3 gauss		0.15		%FS
Repeatability Error	3 sweeps across ±3 gauss		0.11		%FS
<b>ASIC</b>					
Amplifier Gains	No Feedback Connections		225		V/V
Bandwidth				10	kHz
Slew Rate		0.1			V/μsec
Gain Bandwidth	A <sub>v</sub> = 250	1.0			MHz
Phase Margin	A <sub>v</sub> = 250	45			deg
Output Voltage Range	VDD1 = 3.0V	0.15		2.85	V
Output Current	Source Sink	3.6 3.6			mA
<b>Set/Reset Strap Driver</b>					
Reservoir Cap C1	Recommended Capacitor Size	2.2	4.4	10	μF
Load Road Range	Includes Internal 1042 S/R Strap	1.5		6	ohms

# HMC6042

Characteristics	Conditions*	Min	Typ	Max	Units
Internal Strap Resistance		3		6	ohms

## Other

Operating Temperature	Ambient	-40		125	°C
Storage Temperature	Ambient, unbiased	-55		125	°C
Weight			TBD		milli-grams

\* Tested at 25°C except stated otherwise.

## PIN CONFIGURATIONS

(Arrow indicates direction of applied field that generates a positive output voltage after a SET pulse.)

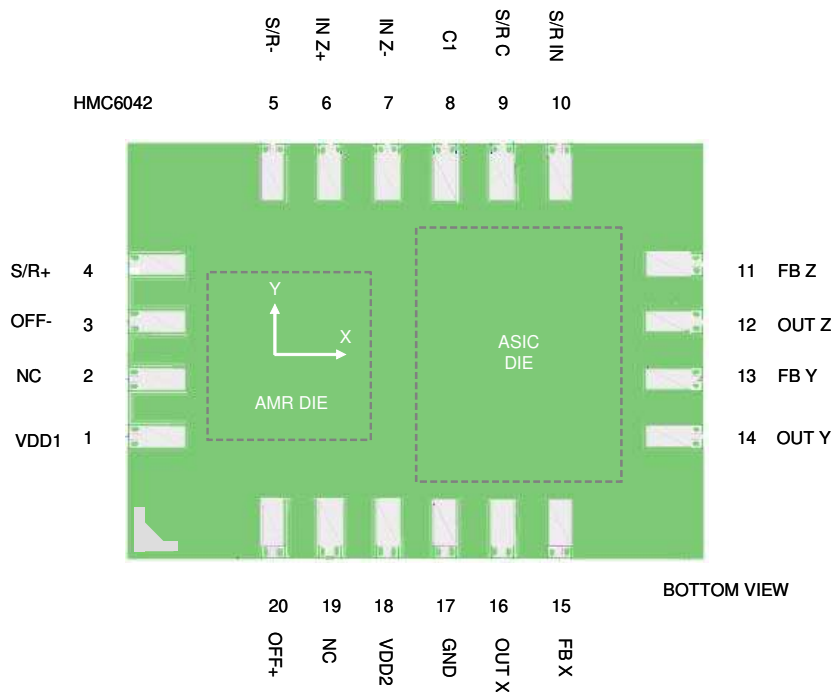

Pin Number	Function
1	VDD1
2	NC
3	Offset Strap-
4	Set/Reset+
5	Set/Reset-
6	Z sensor In+
7	Z sensor In-
8	C1, reservoir cap
9	Set/Reset drive out
10	Set/Reset logic input
11	Z amp feedback
12	Z amp output
13	Y amp feedback
14	Y amp output
15	X amp feedback
16	X amp output
17	GND, ground return
18	VDD2
19	NC
20	Offset Strap+

# HMC6042

## PACKAGE OUTLINES

### PACKAGE DRAWING HMC6042 (20-PIN LCC, dimensions in millimeters)

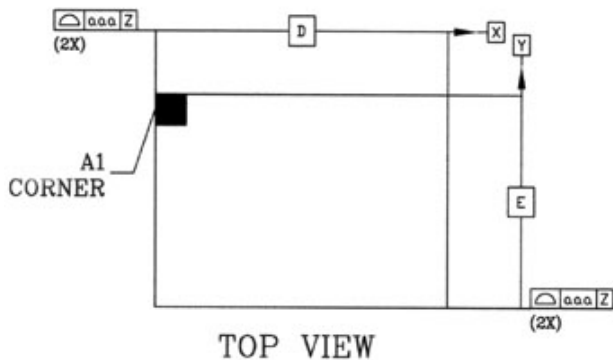

Dimensions	e = 0.5 Basic		
	Minimum	Nominal	Maximum
D		5.00 BSC	
D1		2.50 BSC	
E		3.60 BSC	
E1		1.50 BSC	
A	0.89	1.06	1.23

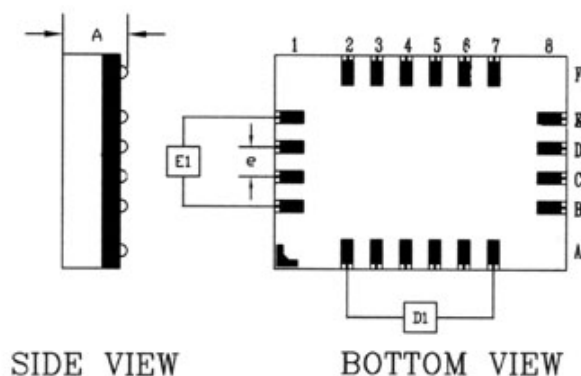

## MOUNTING CONSIDERATIONS

The following is the recommend printed circuit board (PCB) footprint for the HMC6042.

### PCB Pad Definition

The HMC6042 is a fine pitch LCC package with a 0.50mm pin pitch (spacing), with the pin pads defined as 0.50mm by 0.20mm in size. PCB pads are recommended to be oversized by 0.025mm from each pad for a short dimension oversize of 0.05mm. The interior PCB pad is recommended to be 0.05mm oversized per pin with an exterior oversize of 0.20mm for proper package centering and to permit test probing. Lead finish is SnAgCu.

### Stencil Design and Solder Paste

A 4 mil stencil and 100% paste coverage is recommended for the electrical contact pads. The HMC6042 has been tested successfully with no-clean solder paste.

### Pick and Place

Placement is machine dependant and no restrictions are recommended, and have been tested with mechanical centering. Placement force should be equivalent 1206 SMT resistors and enough force should be used to squeeze the paste out from the package/contact pad overlap and to keep the package pin contacts vertical.

### Reflow and Rework

No special profile is required for the HMC6042 and compatible with lead eutectic and lead-free solder paste reflow profiles. Honeywell recommends the adherence to solder paste manufacturer's guidelines. The HMC6042 may be reworked with soldering irons, but extreme care must be taken not to overheat the copper pads from the part's fiberglass

# HMC6042

substrate. Irons with a tip temperature no greater than 315°C should be used. Excessive rework risks the copper pads pulling away into the molten solder.

## SCHEMATIC DIAGRAM

HMC6042

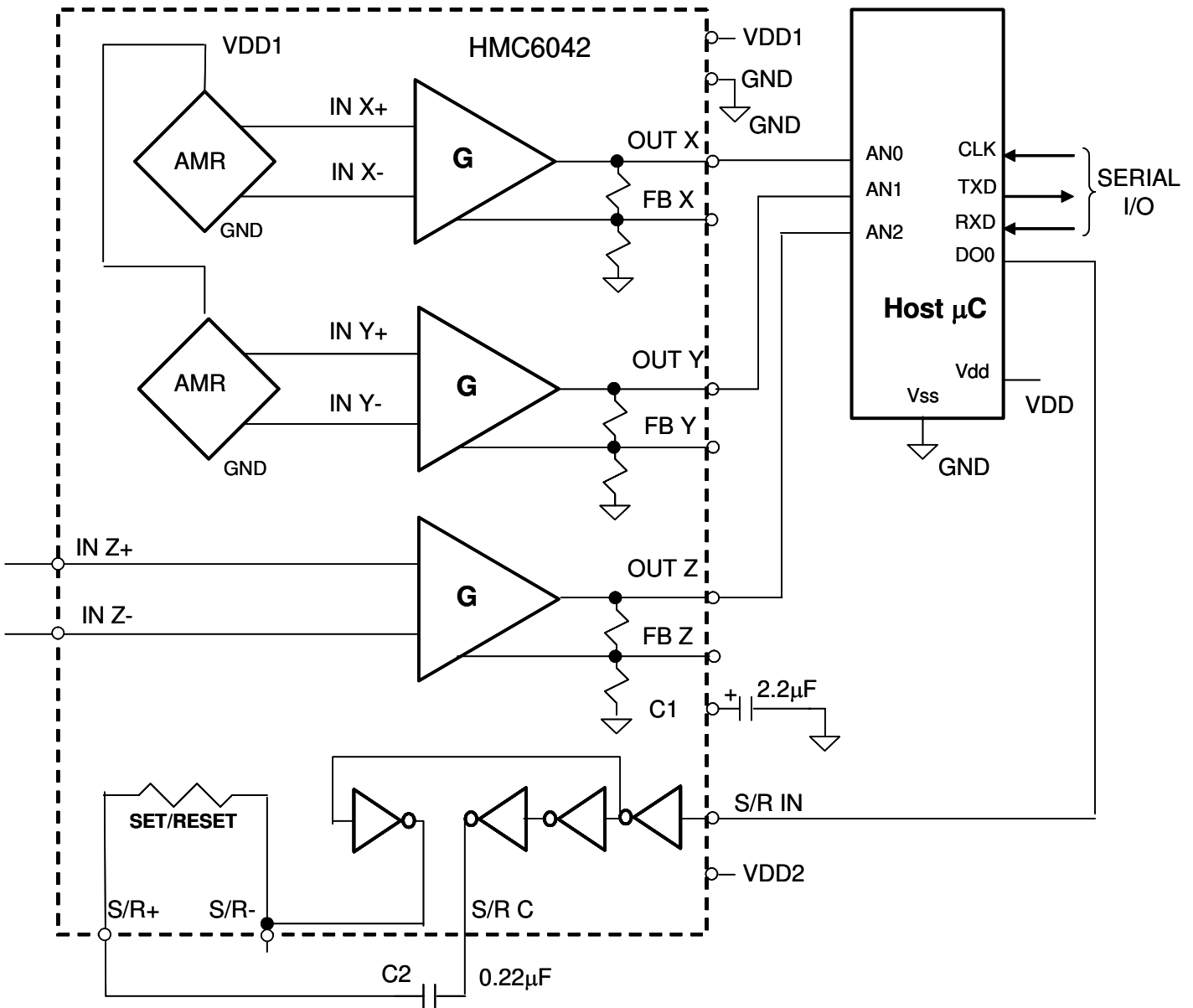

## BASIC DEVICE OPERATION

The Honeywell HMC6042 magnetoresistive sensor circuit is a pair of sensor and analog support circuits to measure magnetic fields. With power supply applied, the sensor converts any incident magnetic field in the sensitive axis direction to a differential voltage output. In addition to the bridge circuit, the sensors have two on-chip magnetically coupled straps; the offset strap and the set/reset strap. These straps are Honeywell patented features for incident field adjustment and magnetic domain alignment; and eliminate the need for external coils positioned around the sensors.

The magnetoresistive sensors are made of a nickel-iron (Permalloy) thin-film deposited on a silicon wafer and patterned as a resistive strip element. In the presence of a magnetic field, a change in the bridge resistive elements causes a corresponding change in voltage across the bridge outputs.

## HMC6042

These resistive elements are aligned together to have a common sensitive axis (indicated by arrows on the pinouts) that will provide positive voltage change with magnetic fields increasing in the sensitive direction. Because the output only is in proportion to the one-dimensional axis (the principle of anisotropy) and its magnitude, additional sensor bridges placed at orthogonal directions permit accurate measurement of arbitrary field direction. The combination of sensor bridges in two and three orthogonal axis permit applications such as compassing and magnetometry.

The offset strap allows for several modes of operation when a direct current is driven through it. These modes are: 1) Subtraction (bucking) of an unwanted external magnetic field, 2) null-ing of the bridge offset voltage, 3) Closed loop field cancellation, and 4) Auto-calibration of bridge gain.

The set/reset strap can be pulsed with high currents for the following benefits: 1) Enable the sensor to perform high sensitivity measurements, 2) Flip the polarity of the bridge output voltage, and 3) Periodically used to improve linearity, lower cross-axis effects, and temperature effects.

### Offset Strap

The offset strap is a spiral of metallization that couples in the sensor element's sensitive axis. The offset strap measures nominally 8 ohms, and requires 10mA for each gauss of induced field. The straps will easily handle currents to buck or boost fields through the  $\pm 6$  gauss linear measurement range, but designers should note the extreme thermal heating on the die when doing so.

With most applications, the offset strap is not utilized and can be ignored. Designers can leave one or both strap connections (Off- and Off+) open circuited, or ground one connection node. Do not tie both strap connections together to avoid shorted turn magnetic circuits.

### Set/Reset Strap

The set/reset strap is another spiral of metallization that couples to the sensor elements easy axis (perpendicular to the sensitive axis on the sensor die). Each set/reset strap has a nominal resistance of 5 ohms with a nominal required peak current of 500mA for reset or set pulses. With rare exception, the set/reset strap must be used to periodically condition the magnetic domains of the magneto-resistive elements for best and reliable performance.

A set pulse is defined as a positive pulse current entering the S/R+ strap connection. The successful result would be the magnetic domains aligned in a forward easy-axis direction so that the sensor bridge's polarity is a positive slope with positive fields on the sensitive axis result in positive voltages across the bridge output connections.

A reset pulse is defined as a negative pulse current entering the S/R+ strap connection. The successful result would be the magnetic domains aligned in a reverse easy-axis direction so that sensor bridge's polarity is a negative slope with positive fields on the sensitive axis result in negative voltages across the bridge output connections.

Typically a reset pulse is sent first, followed by a set pulse a few milliseconds later. By shoving the magnetic domains in completely opposite directions, any prior magnetic disturbances are likely to be completely erased by the duet of pulses. For simpler circuits with less critical requirements for noise and accuracy, a single polarity pulse circuit may be employed (all sets or all resets). With these uni-polar pulses, several pulses together become close in performance to a set/reset pulse circuit. Figure 1 shows a quick and dirty manual pulse circuit for uni-polar application of pulses to the set/reset strap.

### ASIC

Within the HMC6042, the application specific integrated circuit (ASIC) performs the set/reset strap drive and sensor amplification functions. The ASIC has its positive power supply rails broken into VDD1 and VDD2 elements to supply the sensors/amplifiers and set/reset driver respectively. The VDD1 rail with the sensors and amplifiers combined is designed to permit power supply duty cycling to conserve battery energy when the circuit is not used. Both the sensors and amplifiers are designed to stabilize within 1 millisecond after power-up to permit snapshot measurements and return to sleep status. Either PNP or P-MOSFET devices can be used to switch VDD1 off and on. To best ensure minimal energy consumption, place any supply decoupling capacitors outside of the switch transistor, and not across the VDD1 side of the switch.

### Set/Reset Strap Driver

To permit operation from 2.4 to 3.6 volt DC supplies, and provide the required 400mA peak current spikes on the sensor set/reset straps; both a H-bridge driver circuit and capacitive charge pump are employed. Within the H-Bridge drive circuit several totem-pole complementary MOSFET stages are used to buffer the low voltage logic input (S/R\_IN) with the last

## HMC6042

stages composed of 400 milli-ohm switches for high efficiency switching of the set and reset currents. The logic input is expected to be normally high with high-to-low and low-to-high transitions creating reset and set pulses respectively. Typically, the logic low time between pulses is from a half a millisecond to hundreds of milliseconds to accommodate reverse polarity sensor measurements as desired. See application notes AN212 and AN213 for further details on nulling sensor bridge offsets and set/reset strap operation.

To ensure plenty of current at all temperatures, strap load values, and VDD2 supply voltages, a charge pump is designed into the ASIC to push the reservoir capacitor C1 up to a 3.3 volt value. This pump contains its own 25MHz oscillator and is current limited to about 1mA draw for modest but quick charges after set and reset pulse usage. When using C1 values of 2.2 to 10 microfarad, only a small amount of voltage drop occurs on C1 and is quickly recharged to its quiescent voltage. Other than momentary charge pump or set/reset pulse operation, the current draw on VDD2 goes to zero; and can be left on continuous power supply rails indefinitely.

The choice of C1 and C2 capacitor values is dependant on the quantity and type of sensor set/reset straps used. The requirement for the set/reset pulse values are one to two microsecond time constant pulses, with C2 and the set/reset strap load resistance setting the RC time constant. Stand alone, the HMC6042 requires a 0.22 to 0.47 microfarad capacitor, and with the extra HMC1041Z sensor in parallel the values increase to 0.47 to 1.0 microfarad. C1 is typically sized at ten times the C2 value to have minimum voltage droop as a C2 charge is extracted from C1.

### Amplifiers

Three sensor amplifier sections are designed into the ASIC for the embedded HMC1042 two-axis sensors and an optional external third axis sensor. The nominal gain of each amplifier section is about 225 V/V with all three amplifiers fairly close in matched gains. The amplifier sections are broken into two cascaded stages with gains of 22.5 and 10 from input to output. The second stage has a feedback pin brought out to adjust the gain from unity (output and feedback pins shorted) to ten (output and feedback pins open). The second stage feedback resistors are nominally 10k-ohms and sections gains can be trimmed by adding external shunt resistances. Also modest amounts of feedback capacitance can be placed across the output and feedback pins to lower the bandwidth of the amplifiers for greater EMI immunity.

## ORDERING INFORMATION

Ordering Number	Product
HMC6042	Two-Axis Magnetic Sensor Circuit
HMC6042 T/R 1k	Tape and Reel 1k pieces/reel
HMC6042 Cut Tape	Cut Tape

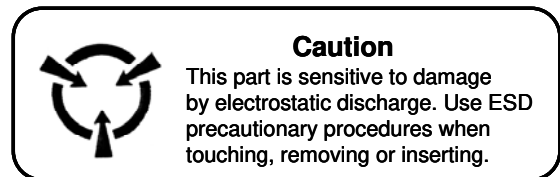

**CAUTION: ESDS CAT. 1A**

## FIND OUT MORE

For more information on Honeywell's Magnetic Sensors visit us online at [www.magneticsensors.com](http://www.magneticsensors.com) or contact us at 800-323-8295 (763-954-2474 internationally).

The application circuits herein constitute typical usage and interface of Honeywell product. Honeywell does not warranty or assume liability of customer-designed circuits derived from this description or depiction.

Honeywell reserves the right to make changes to improve reliability, function or design. Honeywell does not assume any liability arising out of the application or use of any product or circuit described herein; neither does it convey any license under its patent rights nor the rights of others.

U.S. Patents 4,441,072, 4,533,872, 4,569,742, 4,681,812, 4,847,584 and 6,529,114 apply to the technology described