

NO. OF CKTS	A	B
**2	.200 5.08	
3	.300 7.62	.200 5.08
4	.400 10.16	.300 7.62
5	.500 12.70	.400 10.16
6	.600 15.24	.500 12.70
7	.700 17.78	.600 15.24
8	.800 20.32	.700 17.78
9	.900 22.86	.800 20.32
10	1.000 25.40	.900 22.86
11	1.100 27.94	1.000 25.40
12	1.200 30.48	1.100 27.94
13	1.300 33.02	1.200 30.48
14	1.400 35.56	1.300 33.02
15	1.500 38.10	1.400 35.56
16	1.600 40.64	1.500 38.10
17	1.700 43.18	1.600 40.64
18	1.800 45.72	1.700 43.18
19	1.900 48.26	1.800 45.72
20	2.000 50.80	1.900 48.26
21	2.100 53.34	2.000 50.80
22	2.200 55.88	2.100 53.34
23	2.300 58.42	2.200 55.88
24	2.400 60.96	2.300 58.42

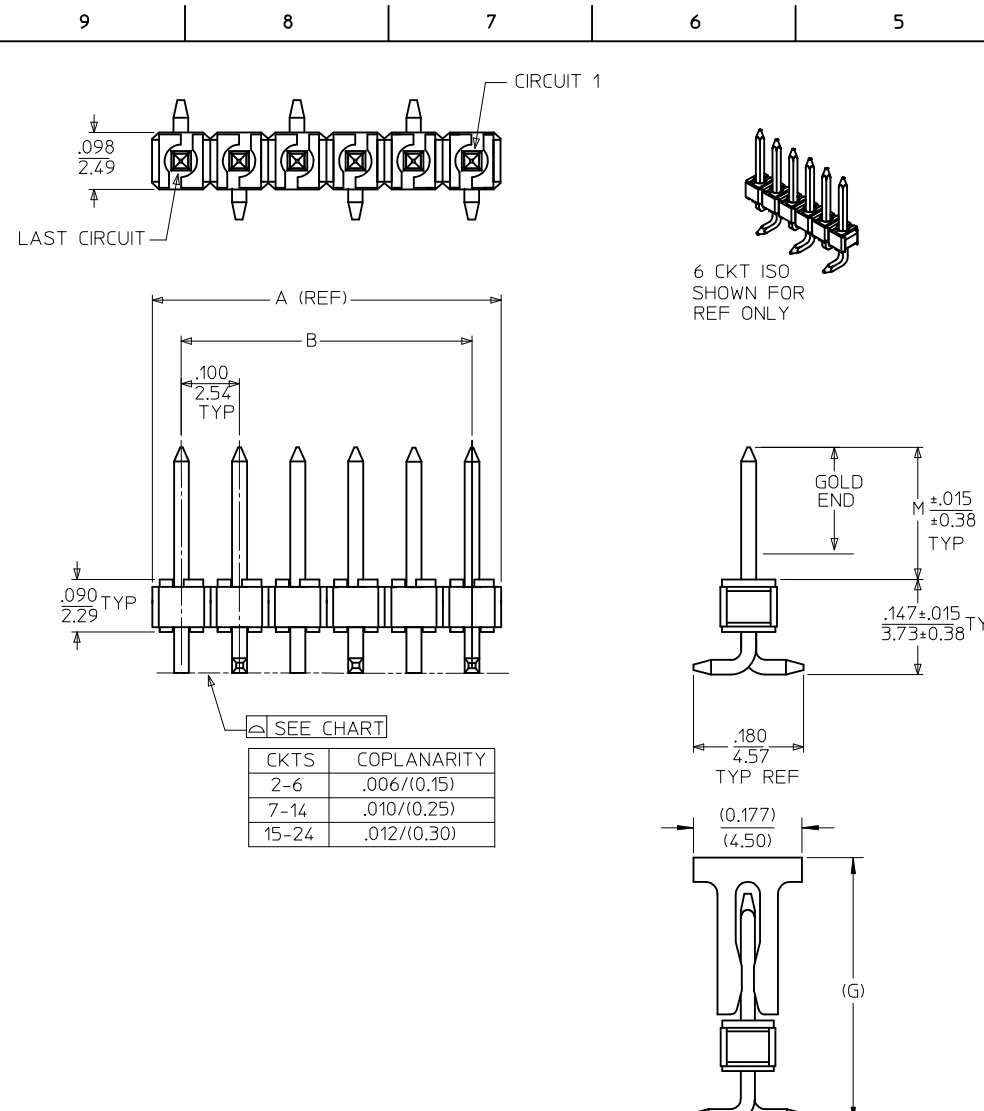

CKTS	COPLANARITY
2-6	.006/(0.15)
7-14	.010/(0.25)
15-24	.012/(0.30)

- NOTES:
- MATERIAL:
HOUSING: NYLON 46, GLASS FILLED, UL94V-0, COLOR: BLACK
PIN: .025/0.64 SQ PIN, PHOSPHOR BRONZE
 - FINISH:
A - *(154) OVERALL TIN: THICKNESS = .000100/0.00254 MIN
B - (208) SELECTIVE GOLD IN CONTACT AREA: THICKNESS = .000015/0.00038 MIN
C - (228) SELECTIVE GOLD IN CONTACT AREA: THICKNESS = .000030/0.00076 MIN.
* SELECTIVE TIN IN PC TAIL AREA: THICKNESS = .000100/0.00254 MIN
OVERALL NICKEL UNDERPLATE: .000050/0.00127 MIN
* THE PRIMARY SHIPPING CARTON WILL BE LABELED, 'COMPLIANT TO RoHS DIRECTIVE 2002/95/EC AND ELV ANNEX II OF DIRECTIVE 2000/53/EC', AND CARTONS WITHOUT THIS LABEL MAY CONTAIN PRODUCT WITH TIN LEAD.
 - PRODUCT SPEC: PS-87920-019
 - PACKAGING INFORMATION:
TUBE PACK : PK-89990-514
TAPE & REEL : PK-68300-001
 - PARTS ARE NOT STACKABLE ON .100/2.54 CENTERS.
 - **6. TWO CKT PARTS WILL REQUIRE SUPPORT DURING THE SOLDER PROCESS.
 - PLEASE CONTACT SALES/ FACTORY FOR TOOLING ACTIVATION OF TAPE & REEL PACKAGING.

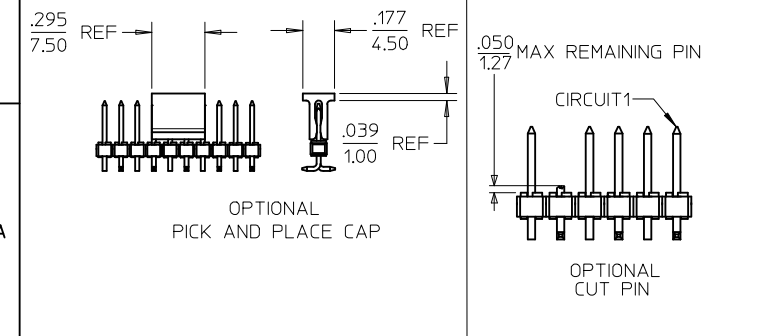
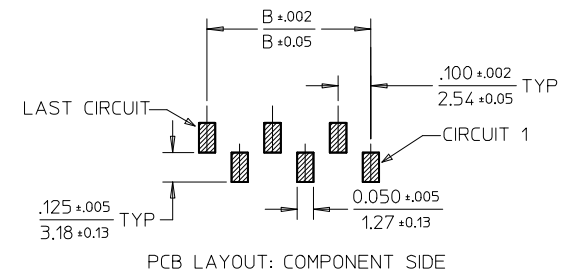

ADD T&R P/N 68301-0400 EC NO: S2009-0634 DRWN:SKANG CHKD:ATSEE APPR:MLONG	2009/04/01 2009/04/06 2009/04/14	DESCRIPTION M6	QUALITY SYMBOLS ▽=0 ∇=0	GENERAL TOLERANCES (UNLESS SPECIFIED)	DIMENSION STYLE IN/MM	SCALE NTS	DESIGN UNITS INCH	THIRD ANGLE PROJECTION
			4 PLACES ± --- ± --- 3 PLACES ± --- ± .005 2 PLACES ± 0.13 ± .010 1 PLACE ± 0.25 ± --- ANGULAR ± 1/2°	DRAWN BY: SAMIAC CHECKED BY: SAMIEC APPROVED BY: EDGLEY	DATE: 2000/10/28 DATE: 2000/10/28 DATE: 2000/10/28	TITLE: CUSTOM HEADER .100/(2.54) CENTERLINE VERTICAL/SMT SINGLE ROW	MOLEX INCORPORATED	
			DRAFT WHERE APPLICABLE MUST REMAIN WITHIN DIMENSIONS	MATERIAL NO. SEE TABLE	DOCUMENT NO. SD-68301-001	SHEET NO. 1 OF 5		
			THIS DRAWING CONTAINS INFORMATION THAT IS PROPRIETARY TO MOLEX INCORPORATED AND SHOULD NOT BE USED WITHOUT WRITTEN PERMISSION					

	10	9	8	7	6	5	4	3	2	1
	MATERIAL NO	OPTIONAL SUB ASSY	PLT REF	DIM M	DIM G	CKT SIZE	VOID CKT #	KINKED PIN	PICK & PLACE CAP	CUT PIN CKT NO.
F	68301-1007	42375-0010	154	.240 6.10	.433 10.99	10	NONE	NONE	YES	-
	68301-1109	42375-0115	154	.320 8.13	-	10	NONE	NONE	-	-
	68301-1159	42375-0116	154	.320 8.13	.513 13.02	11	NONE	NONE	YES	-
	68301-1063	-	154	.240 6.10	-	12	NONE	NONE	-	-
	68301-1111	42375-0117	154	.320 8.13	-	12	NONE	NONE	-	-
	68301-1157	NONE	208	.605 15.37	-	12	NONE	NONE	-	-
E	68301-1065	42375-0014	154	.240 6.10	-	14	NONE	NONE	-	-
	68301-1129	42375-0154	208	.320 8.13	-	14	NONE	NONE	-	-
	68301-1113	42375-0121	154	.320 8.13	-	14	NONE	NONE	-	-
	68301-1066	42375-0015	154	.240 6.10	-	15	NONE	NONE	-	-
	68301-1067	42375-0016	154	.240 6.10	-	16	NONE	NONE	-	-
	68301-1115	42375-0121	154	.320 8.13	-	16	NONE	NONE	-	-
D	68301-1069	42375-0018	154	.240 6.10	-	18	NONE	NONE	-	-
	68301-1117	42375-0123	154	.320 8.13	-	18	NONE	NONE	-	-
	68301-1119	42375-0125	154	.320 8.13	-	20	NONE	NONE	-	-
	68301-1071	42375-0020	154	.240 6.10	-	20	NONE	NONE	-	-
	68301-1072	42375-0021	154	.240 6.10	-	21	NONE	NONE	-	-
	68301-1123	42375-0129	154	.320 8.13	-	24	NONE	NONE	-	-

C										
B										

A	ADD T&R P/N 68301-0400 EC NO: S2009-0634 DRWN:SKANG CHKD:ATSEE APPR:MLONG 2009/04/01 2009/04/06 2009/04/14	QUALITY SYMBOLS = 0 = 0	GENERAL TOLERANCES (UNLESS SPECIFIED) <table border="1"> <tr> <td></td> <td>mm</td> <td>INCH</td> </tr> <tr> <td>4 PLACES</td> <td>± ---</td> <td>± ---</td> </tr> <tr> <td>3 PLACES</td> <td>± ---</td> <td>± .005</td> </tr> <tr> <td>2 PLACES</td> <td>± 0.13</td> <td>± .010</td> </tr> <tr> <td>1 PLACE</td> <td>± 0.25</td> <td>± ---</td> </tr> </table>		mm	INCH	4 PLACES	± ---	± ---	3 PLACES	± ---	± .005	2 PLACES	± 0.13	± .010	1 PLACE	± 0.25	± ---	DIMENSION STYLE IN/MM	SCALE NTS	DESIGN UNITS INCH	THIRD ANGLE PROJECTION
			mm	INCH																		
		4 PLACES	± ---	± ---																		
		3 PLACES	± ---	± .005																		
2 PLACES	± 0.13	± .010																				
1 PLACE	± 0.25	± ---																				
DRAFT WHERE APPLICABLE MUST REMAIN WITHIN DIMENSIONS	DRAWN BY SAMIAC	DATE 2000/10/28	TITLE CUSTOM HEADER .100/(2.54) CENTERLINE VERTICAL/SMT SINGLE ROW																			
M6	APPROVED BY EDGLEY	DATE 2000/10/28	MOLEX INCORPORATED																			
	MATERIAL NO. SEE TABLE	DOCUMENT NO. SD-68301-001	SHEET NO. 2 OF 5																			

10 9 8 7 6 5 4 3 2 1

	MATERIAL NO.	OPTIONAL SUB ASSY	PLT REF	DIM M	DIM G	CKT SIZE	VOID CKT #	KINKED PIN	PICK & PLACE CAP	CUT PIN CKT NO.
F	68301-1054	42375-0002	154	.240 6.10	-	2	NONE	NONE	-	-
	68301-1055	42375-0037	208	.240 6.10	-	2	NONE	NONE	-	-
	68301-1056	42375-0072	228	.240 6.10	-	2	NONE	NONE	-	-
	68301-1051	42375-0107	154	.320 8.13	-	2	NONE	NONE	-	-
	68301-1009	42375-0038	208	.240 6.10	-	3	NONE	NONE	-	-
	68301-1014	42375-0003	154	.240 6.10	-	3	NONE	NONE	-	-
E	68301-1020	42375-0073	228	.240 6.10	-	3	NONE	NONE	-	-
	68301-1031	42375-0108	154	.320 8.13	-	3	NONE	NONE	-	-
	68301-1037	42375-0143	208	.320 8.13	-	3	NONE	NONE	-	-
	68301-1010	42375-0039	208	.240 6.10	-	4	NONE	NONE	-	-
	68301-1015	42375-0004	154	.240 6.10	-	4	NONE	NONE	-	-
	68301-1021	42375-0074	228	.240 6.10	-	4	NONE	NONE	-	-
D	68301-1032	42375-0109	154	.320 8.13	-	4	NONE	NONE	-	-
	68301-0400	-	228	.320 8.13	.513 13.02	4	NONE	NONE	YES	-
	68301-1038	42375-0144	208	.320 8.13	-	4	NONE	NONE	-	-
	68301-1006	42375-0040	208	.240 6.10	-	5	NONE	NONE	-	-
	68301-1016	42375-0005	154	.240 6.10	-	5	NONE	NONE	-	-
	68301-1033	42375-0110	154	.320 8.13	-	5	NONE	NONE	-	-
C	68301-1039	42375-0145	208	.320 8.13	-	5	NONE	NONE	-	-

B



ADD T&R P/N 68301-0400 EC NO: S2009-0634 DRWN:SKANG CHKD:ATSEE APPR:MLONG 2009/04/01 2009/04/06 2009/04/14	QUALITY SYMBOLS ▽=0 ◻=0	GENERAL TOLERANCES (UNLESS SPECIFIED)		DIMENSION STYLE IN/MM		SCALE NTS	DESIGN UNITS INCH	THIRD ANGLE PROJECTION		
				DRAWN BY SAMIAC	DATE 2000/10/28	TITLE CUSTOM HEADER .100/(2.54) CENTERLINE VERTICAL/SMT SINGLE ROW				
				CHECKED BY SAMIEC	DATE 2000/10/28	MOLEX INCORPORATED				
				APPROVED BY EDGLEJ	DATE 2000/10/28	MATERIAL NO. SEE TABLE	DOCUMENT NO. SD-68301-001	SHEET NO. 3 OF 5		
		DRAFT WHERE APPLICABLE MUST REMAIN WITHIN DIMENSIONS			THIS DRAWING CONTAINS INFORMATION THAT IS PROPRIETARY TO MOLEX INCORPORATED AND SHOULD NOT BE USED WITHOUT WRITTEN PERMISSION					

id_frame_A3_P_AM_T Rev. E 2006/04/15 9 8 7 6 5 4 3 2 1

	10	9	8	7	6	5	4	3	2	1	
	ASSEMBLY IN TUBE	ASSEMBLY IN T&R WITH CAP	OPTIONAL SUB ASSY	PLT REF	DIM M	DIM G	CKT SIZE	VOID CKT #	KINKED PIN	PICK & PLACE CAP	CUT PIN CKT NO.
F	68301-1011	-	42375-0041	208	.240 6.10	-	6	NONE	NONE	-	-
	68301-1017	-	42375-0006	154	.240 6.10	-	6	NONE	NONE	-	-
	68301-1034	68301-1160	42375-0111	154	.320 8.13	.513 13.02	6	NONE	NONE	YES	-
	68301-1040	-	42375-0146	208	.320 8.13	-	6	NONE	NONE	-	-
	68301-1023	-	42375-0076	228	.240 6.10	-	6	NONE	NONE	-	-
	68301-1012	-	42375-0042	208	.240 6.10	-	7	NONE	NONE	-	-
E	68301-1018	-	42375-0007	154	.240 6.10	-	7	NONE	NONE	-	-
	68301-1035	-	42375-0112	154	.320 8.13	-	7	NONE	NONE	-	-
	68301-1041	-	42375-0147	208	.320 8.13	-	7	NONE	NONE	-	-
	68301-1013	-	42375-0043	208	.240 6.10	-	8	NONE	NONE	-	-
	68301-1029	-	-	228	.240 6.10	-	8	NONE	NONE	-	-
	68301-1019	-	42375-0008	154	.240 6.10	-	8	NONE	NONE	-	-
D	68301-1028	-	-	228	.505 12.83	-	8	NONE	NONE	-	-
	68301-1036	-	42375-0113	154	.320 8.13	-	8	NONE	NONE	-	-
	68301-1042	-	42375-0148	208	.320 8.13	-	8	NONE	NONE	-	-
	68301-0800	-	-	208	.605 15.37	-	8	NONE	NONE	-	-
	68301-1076	-	42375-0044	208	.240 6.10	-	9	NONE	NONE	-	-
	68301-1060	-	-	154	.240 6.10	-	9	NONE	NONE	-	-

C

B

ADD T&R P/N 68301-0400 EC NO: S2009-0634 DRWN:SKANG CHKD:ATSEE APPR:MLONG	2009/04/01 2009/04/06 2009/04/14	DESCRIPTION REV	QUALITY SYMBOLS  = 0  = 0	GENERAL TOLERANCES (UNLESS SPECIFIED) <table border="1"> <tr> <td></td> <td>mm</td> <td>INCH</td> </tr> <tr> <td>4 PLACES</td> <td>± ---</td> <td>± ---</td> </tr> <tr> <td>3 PLACES</td> <td>± ---</td> <td>± .005</td> </tr> <tr> <td>2 PLACES</td> <td>± 0.13</td> <td>± .010</td> </tr> <tr> <td>1 PLACE</td> <td>± 0.25</td> <td>± ---</td> </tr> </table>		mm	INCH	4 PLACES	± ---	± ---	3 PLACES	± ---	± .005	2 PLACES	± 0.13	± .010	1 PLACE	± 0.25	± ---	DIMENSION STYLE IN/MM	SCALE NTS	DESIGN UNITS INCH	 THIRD ANGLE PROJECTION
				mm	INCH																		
			4 PLACES	± ---	± ---																		
			3 PLACES	± ---	± .005																		
2 PLACES	± 0.13	± .010																					
1 PLACE	± 0.25	± ---																					
DRAWN BY: SAMIAC DATE: 2000/10/28 CHECKED BY: SAMIEC DATE: 2000/10/28 APPROVED BY: EDGLEY DATE: 2000/10/28		TITLE CUSTOM HEADER .100/(2.54) CENTERLINE VERTICAL/SMT SINGLE ROW																					
MATERIAL NO. SEE TABLE		DOCUMENT NO. SD-68301-001																					
DRAFT WHERE APPLICABLE MUST REMAIN WITHIN DIMENSIONS		SIZE A3																					

CKT SIZE	QTY/ REEL	Ao	Ko	F	So	W	TYPE
4	TBD	4.85	13.40	11.50	-	24.00	B
6	230	4.85	13.40	14.20	28.40	32.00	A
10	230	4.90	11.30	20.20	40.40	44.00	A

EMBOSSED TYPE A

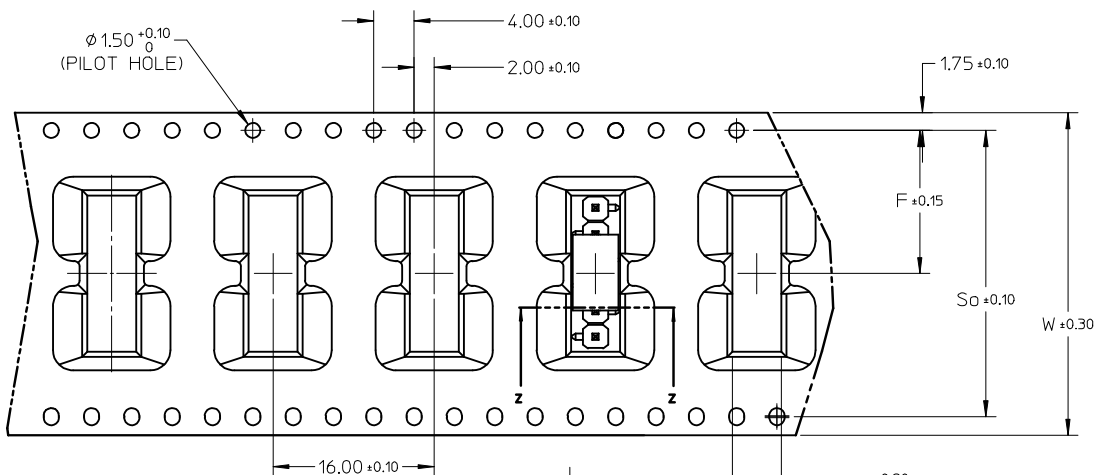

CUSTOMER PULL OUT DIRECTION

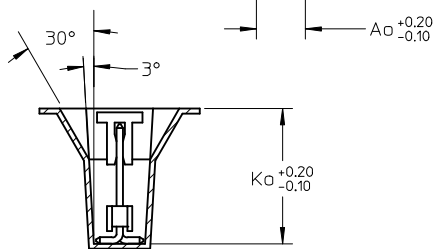

SECTION Z-Z

EMBOSSED TYPE B

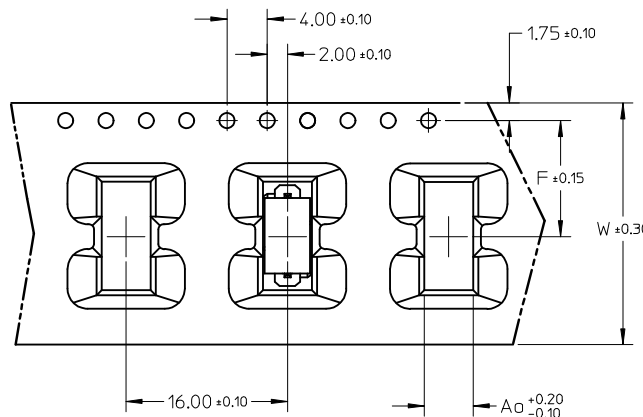

CUSTOMER PULL OUT DIRECTION

NOTES:

1. LEADER AND TRAILER TAPE

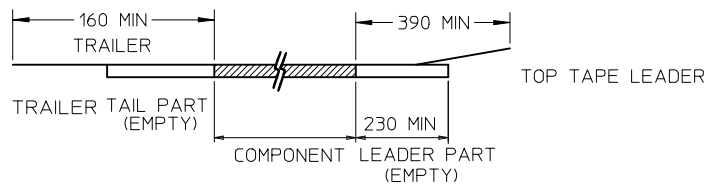

2. PEELING OFF FORCE OF THE TOP TAPE: 60gf MAX.
(PEELING DIRECTION AS SHOWN IN FOLLOWING FIGURE)



3. THE TAPE IS TREATED FOR ANTI ESD
4. PACKAGING STANDARD AS PER EIA-481.
5. ABOVE PACKAGING ILLUSTRATION IS FOR 6CKT ONLY.

ADD T&R P/N 68301-0400 EC NO: S2009-0634 DRWN:SKANG CHKD:ATSEE APPR:MLONG	2009/04/01 2009/04/06 2009/04/14	QUALITY SYMBOLS	GENERAL TOLERANCES (UNLESS SPECIFIED)	DIMENSION STYLE	SCALE	DESIGN UNITS	THIRD ANGLE PROJECTION													
		$\nabla=0$ $\nabla C=0$	<table border="1"> <thead> <tr> <th></th> <th>mm</th> <th>INCH</th> </tr> </thead> <tbody> <tr> <td>4 PLACES</td> <td>± ---</td> <td>± ---</td> </tr> <tr> <td>3 PLACES</td> <td>± ---</td> <td>± .005</td> </tr> <tr> <td>2 PLACES</td> <td>± 0.13</td> <td>± .010</td> </tr> <tr> <td>1 PLACE</td> <td>± 0.25</td> <td>± ---</td> </tr> </tbody> </table>		mm	INCH	4 PLACES	± ---	± ---	3 PLACES	± ---	± .005	2 PLACES	± 0.13	± .010	1 PLACE	± 0.25	± ---	IN/MM	NTS
	mm	INCH																		
4 PLACES	± ---	± ---																		
3 PLACES	± ---	± .005																		
2 PLACES	± 0.13	± .010																		
1 PLACE	± 0.25	± ---																		

DRAWN BY SAMIAC CHECKED BY SAMIAC APPROVED BY EDGLEY	DATE 2000/10/28 2000/10/28 2000/10/28	TITLE CUSTOM HEADER .100/(2.54) CENTERLINE VERTICAL/SMT SINGLE ROW	MATERIAL NO. SEE TABLE	DOCUMENT NO. SD-68301-001	SHEET NO. 5 OF 5

SIZE A3	THIS DRAWING CONTAINS INFORMATION THAT IS PROPRIETARY TO MOLEX INCORPORATED AND SHOULD NOT BE USED WITHOUT WRITTEN PERMISSION
------------	---