

ABSOLUTE MAXIMUM RATINGS (Voltage Referencec

Rating	Symbol	Value
DC Supply Voltage	$V_{DD} - V_{SS}$	-0.5 to 6
Voltage, Any Pin to V_{SS}	V	-0.5 to $V_{DD} +$
DC Current, Any Pin (Excluding V_{DD} , V_{SS})	I	± 10
Operating Temperature	T_A	-40 to 85
Storage Temperature	T_{stg}	-85 to 150

RECOMMENDED OPERATING CONDITIONS ($T_A =$

Parameter	Symbol	Min	Max	Unit
DC Supply Voltage	V_{DD}	4.5	5.5	V
Power Dissipation ($\overline{P_D} = V_{DD}$)	$V_{DD} = 5 V$	0	100	mW
Power Dissipation ($\overline{P_D} = V_{SS}$)	$V_{DD} = 5 V$	0	100	mW
Frame Rate			100	M
CCI CLK Frequency (MSI = 8 kHz) UDLT-1 (CCI = 256 x MSI) UDLT-2			100	kHz
Frame Rate Slip*				%
Data Clock Rate (Master Mode) UDLT-1 UDLT-2			100	kHz
SDCLK (UDLT-2 Only)			100	kHz
Modulation Baud Rate UDLT-1 UDLT-2			100	kHz

* The slave's crystal frequency divided by 512 (UDLT-1) or 1024 (UDLT-2) operation.

Product Preview
Universal Digital Loop Transceiver (UDLT-3)
Pin Selectable Master/Slave Limited Distance Modem

The MC145423 is a CMOS integrated circuit designed to integrate the major building blocks in digital subscriber voice/data telephone systems and remote data acquisition and control systems.

The UDLT-3 incorporates into one device, all the functions of the MC145421 (ISDN UDLT-2 master), MC145425 (ISDN UDLT-2 slave), MC145422 (UDLT-1 master), and MC145426 (UDLT-1 slave).

Since these modes/functions are pin selectable, the MC145423 can be used in telephone switch line cards, as well as remote data terminals or telsets or data terminals.

- $V_{DD} = 4.5 V$ to $5.5 V$
- 28-Pin SOIC and TSSOP Packages
- Protocol Independent
- Pin Controlled Power-Down
- LI Sensitivity Control in Master Mode
- 2.048 MHz Output in Slave Mode

UDLT-2 Features

- Synchronous Full Duplex 160 kbps Voice and Data Communications in a 2B+2D Format for ISDN Compaction Mode
- Provides CCITT Basic Access Data Transfer Rate (2B+2D) for ISDNs on a Single Twisted Pair Up to 1 km on 26 AWG or Larger Cable

UDLT-1 Features

- Pin Controlled Loopback
- Automatic Power-Up/Down (Slave)
- Full Duplex Synchronous 64 kbps Voice/Data Channel and 8 kbps Signaling Data Channels Over One 26 AWG Wire Pair Up to 2 km

This document contains information on a product under development. Motorola reserves the right to change or discontinue this product without notice.

© Motorola, Inc., 2000. All rights reserved.

PIN ASSIGN

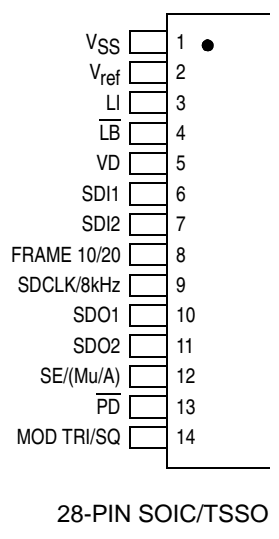

BLOCK D

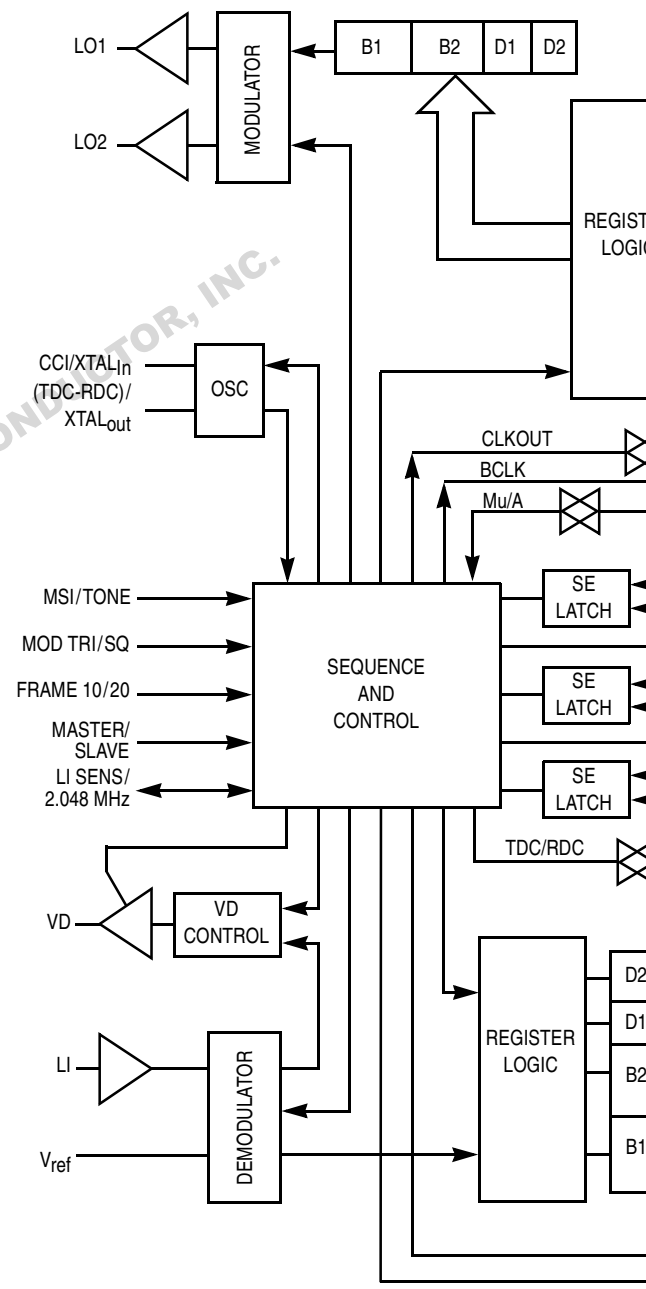

ARCHIVED BY FREESCALE SEMICONDUCTOR, INC.

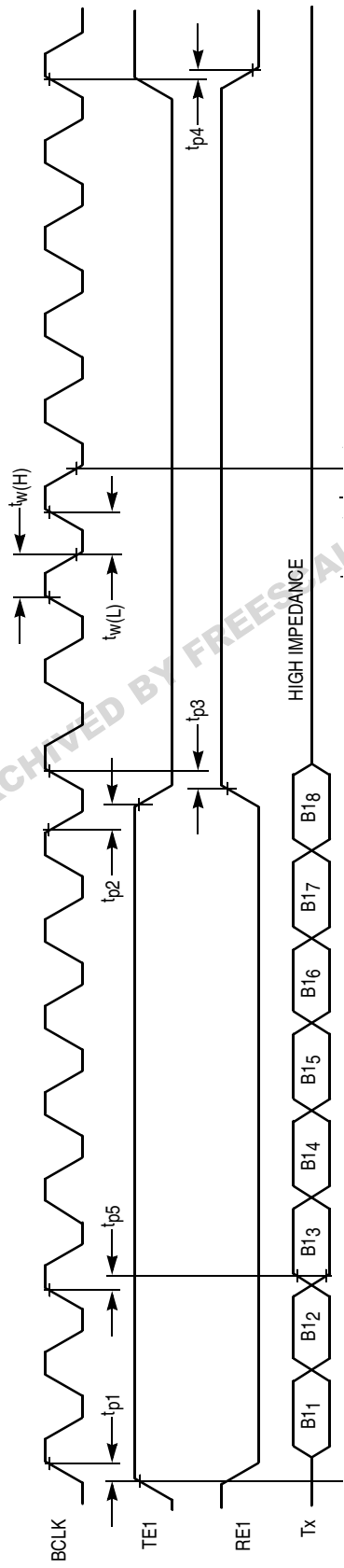

Figure 1. UDLT-1 Slave 1

DIGITAL CHARACTERISTICS ($V_{DD} = 5\text{ V} \pm 10\%$, $T_A =$

Parameter
Input High Level
Input Low Level
Input Current (Digital Pins)
Input Current LI
Input Capacitance
Output High Current (Excluding Tx and $\overline{\text{PD}}$)
Output Current Low (Excluding Tx and $\overline{\text{PD}}$)
Tx Output High Current
Tx Output Low Current
$\overline{\text{PD}}$ Output High Current — Slave Mode*
$\overline{\text{PD}}$ Output Low Current — Slave Mode*
Tx, SDO1, SDO2, and VD Three-State Current
XTAL Output High Current
XTAL Output Low Current

* To overdrive $\overline{\text{PD}}$ from a low level to 3.5 V, or a high level to 1.5 V req

ANALOG CHARACTERISTICS ($V_{DD} = 5\text{ V} \pm 10\%$, $T_A =$

Parameter
Modulation Differential Amplitude ($R_L = 440\ \Omega$)
Modulation Differential Offset
V_{ref} Voltage, Typically $9/20 \times (V_{DD} - V_{SS})$
PCM Tone Level
Demodulator Input Amplitude*
Demodulator Input Impedance (LI to V_{ref})

* The input level into the demodulator to reliably demodulate incoming

MASTER SWITCHING CHARACTERISTICS ($V_{DD} =$

Parameter	Unit
Input Rise Time: All Digital Inputs	
Input Fall Time: All Digital Inputs	
Pulse Width: TDC, RDC, RE1, RE2, MSI, SDCLK (UDLT-2)	
CCI Duty Cycle	
Propagation Delay: MSI to SDO1, SDO2, VD ($\overline{PD} = V_{DD}$) TDC to Tx	
MSI, TE1, TE2, RE1, RE2 to TDC-RDC Setup Time	
TDC-RDC to MSI, TE1, TE2, RE1, RE2, Hold Time	
Rx to TDC-RDC Setup Time	
Rx to TDC-RDC Hold Time	
SDI1, SDI2 to MSI Setup Time	
SDI1, SDI2 to MSI Hold Time	
MSI Rising Edge to First SDCLK Falling Edge (UDLT-2 Only)	
TE Rising Edge to First Tx Data Bit Valid	
TDC-RDC Rising Edge to Tx Data Bits 2 – 8 Valid	
TE1, TE2 Falling Edge to Tx High Impedance	
SDCLK Rising Edge to SDO1, SDO2 Bit Valid (UDLT-2 Only)	
SDI1, SDI2 Data Setup (Data Valid Before SDCLK Falling Edge) (UDLT-2 Only)	
SDI1, SDI2 Data Hold (Data Valid After SDCLK Falling Edge) (UDLT-2 Only)	
\overline{PD} , \overline{LB} Setup (\overline{PD} , \overline{LB} Valid Before MSI Rising Edge)	
\overline{PD} , \overline{LB} Hold (\overline{PD} , \overline{LB} Valid After MSI Rising Edge)	

SLAVE SWITCHING CHARACTERISTICS ($V_{DD} = 5$

Parameter	Unit
Input Rise Time: All Digital Inputs	
Input Fall Time: All Digital Inputs	
Clock Output Pulse Width: BCLK	
Crystal Frequency	
Propagation Delay Times: EN1, EN2, TE1 Rising to BCLK (TONE = V_{DD}) EN1, EN2, TE1 Rising to BCLK (TONE = V_{SS}) BCLK to EN1, EN2, TE1 Falling RE1 Rising to BCLK (UDLT-1) RE1 Falling to BCLK (TONE = V_{DD}) (UDLT-1) RE1 Falling to BCLK (TONE = V_{SS}) (UDLT-1) BCLK to Tx TE1, TE2 to SDO1, SDO2	
Rx to BCLK Setup Time	
Rx to BCLK Hold Time	
SDI1, SDI2 to TE Setup Time	
SDI1, SDI2 to TE Hold Time	
EN1, EN2 Rising Edge to DCLK Rising Edge (UDLT-2)	
EN1, EN2 Rising Edge to First Tx Data Bit Valid	
BCLK Rising Edge to Tx Data Bits 2 – 8 Valid	
DCLK Pulse Width High (UDLT-2)	
DCLK Pulse Width Low (UDLT-2)	
DCLK Rising Edge to SDO1, SDO2 (UDLT-2)	
SDI1, SDI2 Setup (SDI1, SDI2 Valid Before DCLK Falling Edge) (UDLT-2)	
SDI1, SDI2 Hold (SDI1, SDI2 Valid After DCLK Falling Edge) (UDLT-2)	
EN1, TE1 Rising Edge to VD Valid	

SE PIN TIMING

Parameter	Unit
\overline{LB} , \overline{PD} Hold (\overline{LB} , \overline{PD} Valid After SE Falling Edge)	
SDO1, SDO2, VD High Impedance After SE Falling Edge	
SDO1, SDO2, VD Valid After SE Rising Edge	
\overline{LB} , \overline{PD} Setup (\overline{LB} , \overline{PD} Valid Before SE Rising Edge)	

Freescale Semiconductor, Inc.

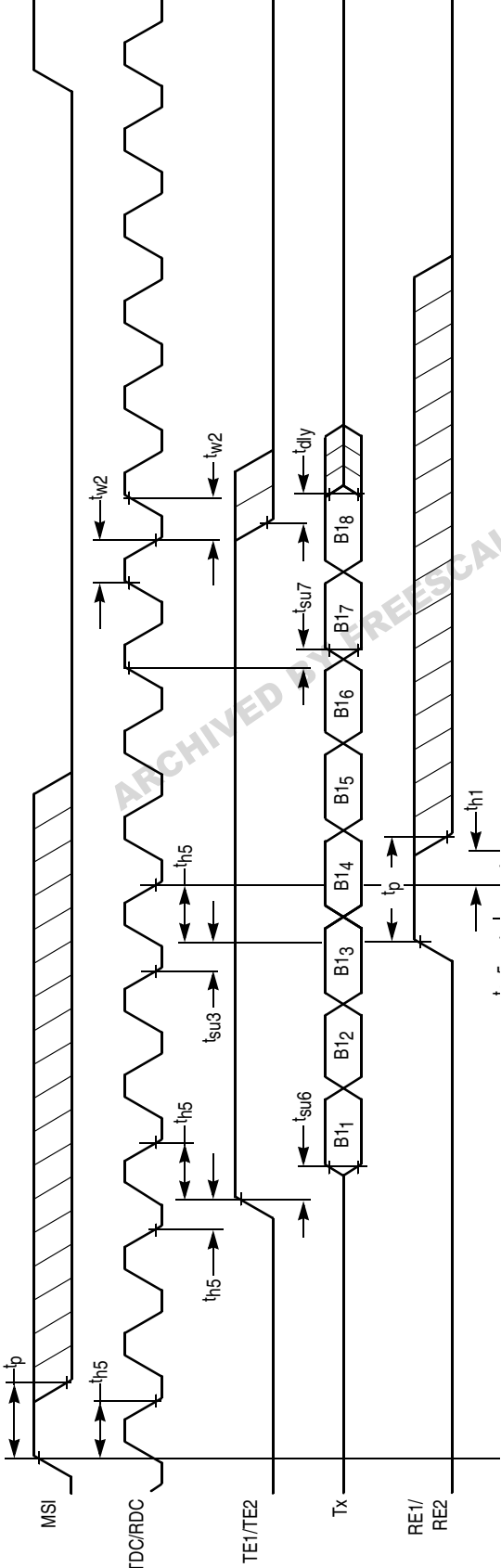

Figure 5. UDLT-

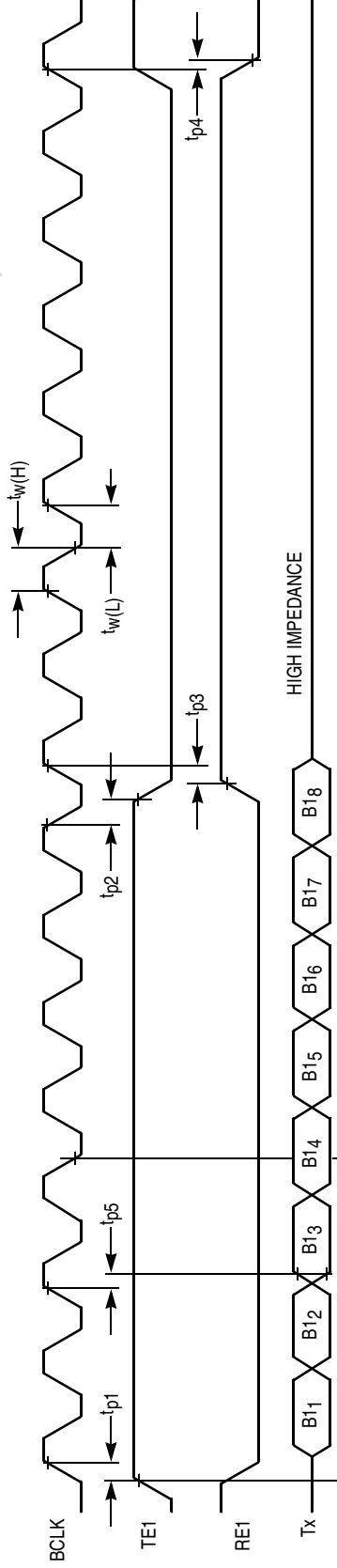

Figure 2. UDLT-1 Slave

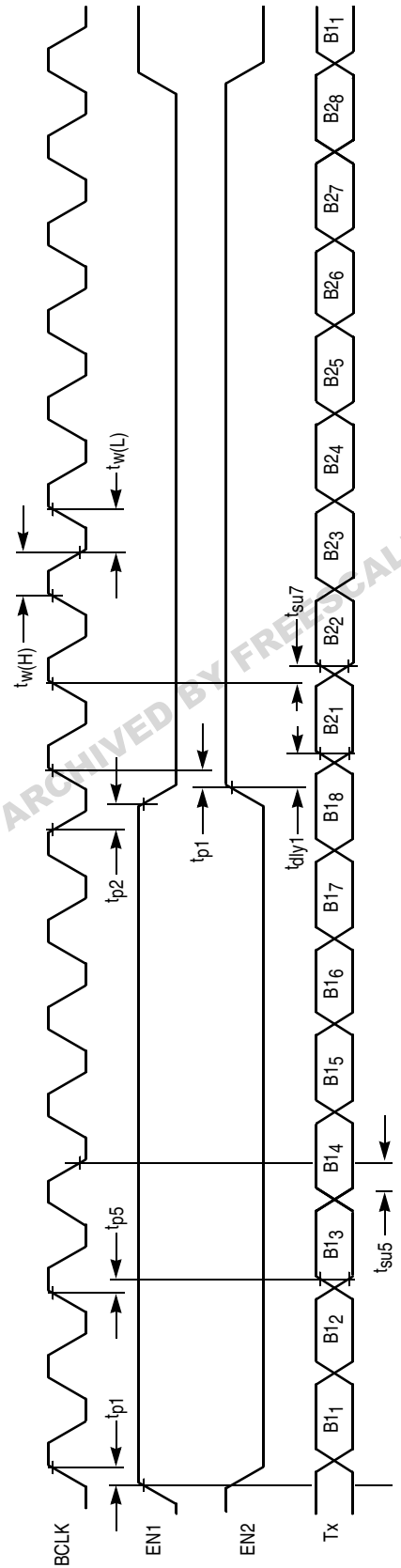

Figure 3. UDLT-

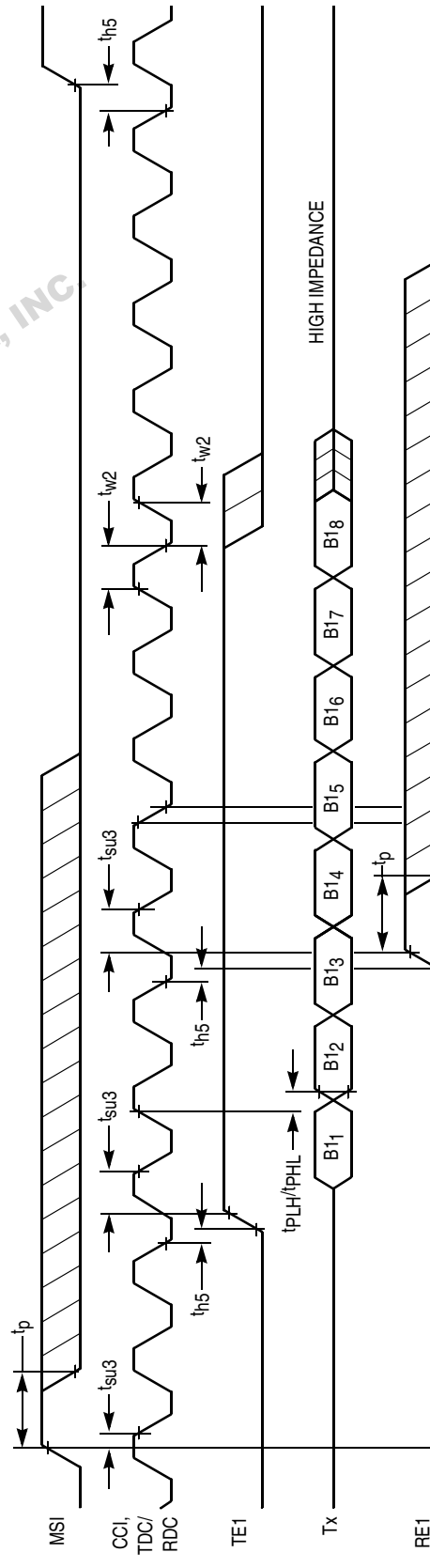

Figure 4. UDLT-

MC145423 UDLT-3 PIN STATES FOR UDLT-1 SLA

MC145423			UDLT-1 Slave Mode Powered-Up	
Pin No.	Pin Name	In/out	Normal	$\overline{\text{LB}}$ Low
23	RE2/ BCLK	Output	BCLK = 128 kHz	BCLK = 0
24	Rx	Input	64 kbps Data In	Don't Care
25	LO2	Output	Modulator Out	Modulator Out
26	LO1	Output	Modulator Out	Modulator Out
27	MASTER/ SLAVE	Input	1	1
28	VDD	Power	+V	+V

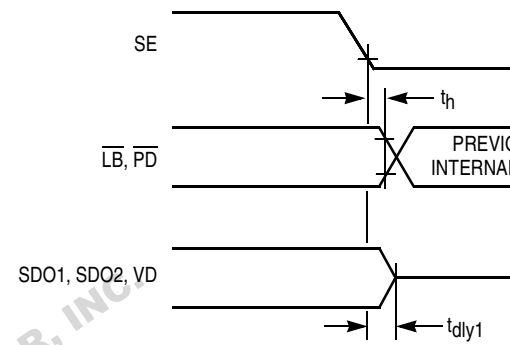

Figure 6. SE

MC145423 UDLT-3 PIN STATES FOR UDLT-1 MAS

MC145423			UDLT-1 Master Mode Powered-Up	
Pin No.	Pin Name	In/out	Normal	$\overline{\text{LB}}$ Low
1	VSS	Power	Power Supply Gnd	Power Gnd
2	Vref	Analog Ref	AGND V _{DD} /2	AGND
3	LI	Input	Analog In	Don't Care
4	$\overline{\text{LB}}$	Input	1	0
5	VD	Output	Digital out	Digital out
6	SDI1	Input	8 kbps Data In	8 kbps Data In
7	SDI2	Input	8 kbps Data In	8 kbps Data In
8	FRAME 10/20	Input	0	0
9	SDCLK	Don't Care	High Impedance	High Imp edance
10	SDO1	Output	8 kbps Data Out	8 kbps Data Out
11	SDO2	Output	8 kbps Data Out	8 kbps Data Out
12	SE/(Mu/A)	Input	1	1
13	$\overline{\text{PD}}$	Input	1	1
14	MOD TRI/SQ	Input	0	0
15	Tx	Output	64 kbps Data Out	64 k Data Out
16	EN2-TE2/ SIE/B1B2	Input	SIE Digital In	SIE Di gital In

SOIC PACKAGE PIN
UDLT-3 PINOUT VERSUS MC145421DW/22DW/25 (UDLT-1/UDLT-2 MASTER/SLAVE) PINOUT

UDLT-3 MC145423		UDLT-1 Master MC145422		UDLT-1 MC145421	
Pin No.	Pin Name	Pin No.	Pin Name	Pin No.	Pin Name
1	VSS	1	VSS	1	
2	Vref	2	Vref	2	
3	LI	3	LI	3	
4	LB	5	LB	5	
5	VD	6	VD	6	
6	SDI1	7	SI1	7	
7	SDI2	9	SI2	9	
8	FRAME 10/20	Logic 0		Log	
9	SDCLK/8kHz	High Impedance		SDC	
10	SDO1	8	SO1	8	
11	SDO2	10	SO2	10	
12	SE/(Mu/A)	11	SE	11	
13	PD	12	PD	12	
14	MOD TRI/SQ	Logic 0		Log	
15	Tx	16	Tx	15	
16	EN2-TE2/SIE/B1B2	14	SIE	B1 Log	
17	EN1-TE1	15	TE1	14	
18	MSI/TONE	13	MSI	13	(
19	CCI/XTAL _{in}	17	CCI	16	(X
20	TDC-RDC/XTAL _{out}	18	TDC/RDC	17	(XT
21	LI SENS/2.048 MHz	Logic 0 LI SENS		2.048 M	
22	RE1/CLKOUT	20	RE1	20	
23	RE2/BCLK	High Impedance		18	(B
24	Rx	19	Rx	19	
25	LO2	22	LO2	22	
26	LO1	23	LO1	23	
27	MASTER/SLAVE	Logic 0		Log	
28	VDD	24	VDD	24	

MC145423 UDLT-3 PIN STATES FOR UDLT-1 SLAVE

MC145423			UDLT-1 Slave Mode Powered-Up	
Pin No.	Pin Name	In/out	Normal	LB Low
1	VSS	Power	Power Supply Gnd	Power Supply Gnd
2	Vref	Analog Ref	AGND VDD/2	AGND VDD/2
3	LI	Input	Analog In	Analog In
4	LB	Input	1	0
5	VD	Output	Digital Out	Digital Out
6	SDI1	Input	8 kbps Data In	8 kbps Data In
7	SDI2	Input	8 kbps Data In	8 kbps Data In
8	FRAME 10/20	Input	0	0
9	SDCLK/8kHz	Output	SDCLK/8kHz	SDCLK/8kHz
10	SDO1	Output	8 kbps Data Out	8 kbps Data Out
11	SDO2	Output	8 kbps Data Out	8 kbps Data Out
12	SE/(Mu/A)	Input	1= Mu, 0 = A	1= Mu, 0 = A
13	PD	I/O	1	1
14	MOD TRI/SQ	Input	0	0
15	Tx	Output	64 kbps Data Out	64 kbps Data Out
16	EN2-TE2/SIE/B1B2	Input	1/0 B1B2	1/0 B1B2
17	EN1-TE1	Output	EN1 = 8 kHz	EN1 = 8 kHz
18	MSI/TONE	Input	1/0 TONE	1/0 TONE
19	CCI/XTAL _{in}	Input	XTAL _{in} 4.096 MHz	XTAL _{in} 4.096 MHz
20	TDC-RDC/XTAL _{out}	Output	XTAL _{out} 4.096 MHz	XTAL _{out} 4.096 MHz
21	LI SENS/2.048 MHz	Output	2.048 MHz	2.048 MHz
22	RE1/CLKOUT	Output	RE1 = 8 kHz	RE1 = 8 kHz

Freescale Semiconductor, Inc.

PIN DESCRIPTIONS
V_{SS}
Negative Supply (Pin 1)

This is the most negative power pin, and should be tied to system ground (0 V).

V_{ref}
Voltage Reference Output (Pin 2)

This is the output from the internal reference supply (mid-supply) and should be bypassed to both V_{SS} and V_{DD} with 0.1 μF capacitors. This pin usually serves as an analog ground reference for transformer coupling of the device's incoming bursts from the line. No external load should be placed on this pin.

LI
Line Input (Pin 3)

This pin is the input to the demodulator for the incoming bursts. This input has an internal 240 kΩ resistor tied to the V_{ref} pin, so an external capacitor or line transformer may be used to couple the input signal to the device with no dc offset.

LB
Loopback Low Input (Pin 4)

Master Mode: A low on this pin ties the internal modulator output to the internal demodulator input, which loops the entire burst for testing purposes. During the loopback operation, the LI input is ignored, and the LO1 and LO2 outputs are driven to equal voltages. The state of the LB pin is internally latched if the SE pin is held low. This feature is only active when the PD input is high.

Slave Mode: When this pin is low and PD is high, the incoming B channels from the master are burst back to the master, instead of the Rx B channel input data. The SDI1 and SDI2 functions operate normally in this mode, and the BCLK (pin 23) is held low. Additionally, for both the UDLT-1 and UDLT-2 mode, when the TONE (pin 18) and loopback functions are active simultaneously, the loopback function overrides the TONE function.

VD
Valid Data Output (Pin 5)

A high level on this pin indicates that a valid line transmission has been demodulated. A valid line transmission burst is determined by proper

MC145423 UDLT-3 PIN STATES FOR UDLT-1 MASTER MODE

MC145423			UDLT-1 Master Mode Powered-Up	
Pin No.	Pin Name	In/out	Normal	LB Low
17	EN1-TE1	Input	TE1 8 kHz	TE1 8 kHz
18	MSI/TONE	Input	MSI 8 kHz	MSI 8 kHz
19	CCI/ XTAL _{in}	Input	CCI 2.048 MHz	CCI 2.048 MHz
20	TDC-RDC/ XTAL _{out}	Input	TDC-RDC Data Clk	TDC-RDC Data Clk
21	LI SENS/ 2.048 MHz	Input	Digital In LI Sensitivity	Digital In LI Sensitivity
22	RE1/ CLKOUT	Input	RE1 8 kHz	RE1 8 kHz
23	RE2/ BCLK	Don't Care	High Impedance	High Impedance
24	Rx	Input	64 kbps Data In	64 kbps Data In
25	LO2	Output	Modulator Out	LO2 = LO1
26	LO1	Output	Modulator Out	LO1 = LO2
27	MASTER/ SLAVE	Input	0	0
28	V _{DD}	Power	+V	+V

MC145423 UDLT-3 PIN STATES FOR UDLT-2 SLAVE MODE

MC145423			UDLT-2 Slave Mode Powered-Up	
Pin No.	Pin Name	In/out	Normal	LB Low
1	V _{SS}	Power	Power Supply Gnd	Power Supply Gnd
2	V _{ref}	Analog Ref	AGND V _{DD} /2	AGND V _{DD} /2
3	LI	Input	Analog In	Analog In
4	LB	Input	1	0
5	VD	Output	Digital Out	Digital Out
6	SDI1	Input	16 kbps Data In	16 kbps Data In
7	SDI2	Input	16 kbps Data In	16 kbps Data In
8	FRAME 10/20	Input	1	1
9	SDCLK	Output	16 kHz	16 kHz

MC145423 UDLT-3 PIN STATES FOR UDLT-2 SLA

MC145423			UDLT-2 Slave Mode Powered-Up	
Pin No.	Pin Name	In/out	Normal	$\overline{\text{LB}}$ Low
10	SDO1	Output	16 kbps Data Out	16 kbps Data Out
11	SDO2	Output	16 kbps Data Out	16 kbps Data Out
12	SE/ (Mu/A)	Input	1/0 Mu/A	1/0 Mu/A
13	$\overline{\text{PD}}$	I/O	1	1
14	MOD TRI/SQ	Input	1	1
15	Tx	Output	128 kbps Data Out*	128 kbps Data Out*
16	EN2-TE2/ SIE/B1B2	Output	EN2 8 kHz	EN2 8 kHz
17	EN1-TE1	Output	EN1 8 kHz	EN1 8 kHz
18	MSI/ TONE	Input	1/0 Tone	1/0 Tone
19	CCI/ XTAL _{in}	Input	XTAL 8.192 MHz	XTAL 8.192 MHz
20	TDC-RDC/ XTAL _{out}	Output	XTAL 8.192 MHz	XTAL 8.192 MHz
21	LI SENS/ 2.048 MHz	Output	2.048 MHz	2.048 MHz
22	RE1/ CLKOUT	Output	RE1 8 kHz	RE1 8 kHz
23	RE2/ BCLK	Output	BCLK 128 kHz	BCLK = 0
24	Rx	Input	128 kbps Data In	Don't Care
25	LO2	Output	Modulator Out	Modulator Out
26	LO1	Output	Modulator Out	Modulator Out
27	MASTER/ SLAVE	Input	1	1
28	V _{DD}	Power	+V	+V

* Tx is high impedance when TE1 and TE2 are both low, simultaneous
Tx is undefined when TE1 and TE2 are both high, simultaneously.

MC145423 UDLT-3 PIN STATES FOR UDLT-2 MASTER

MC145423			UDLT-2 Master	
Pin No.	Pin Name	In/out	Normal	$\overline{\text{LB}}$ Low
1	V _{SS}	Power	Power Supply Gnd	Power Supply Gnd
2	V _{ref}	Analog Ref	AGND V _{DD} /2	AGND
3	LI	Input	Analog In	Don't Care
4	$\overline{\text{LB}}$	Input	1	0
5	VD	Output	Digital Out	Digital Out
6	SDI1	Input	16 kbps Data In	16 kbps Data In
7	SDI2	Input	16 kbps Data In	16 kbps Data In
8	FRAME 10/ 20	Input	1	1
9	SDCLK	Input	16 kHz	16 kHz
10	SDO1	Output	16 kbps Data Out	16 kbps Data Out
11	SDO2	Output	16 kbps Data Out	16 kbps Data Out
12	SE/(Mu/A)	Input	1	1
13	$\overline{\text{PD}}$	Input	1	1
14	MOD TRI/SQ	Input	1	1
15	Tx	Output	128 kbps* Data Out	128 kbps Data Out
16	EN2-TE2/ SIE/B1B2	Input	TE2 8 kHz	TE2 8 kHz
17	EN1-TE1	Input	TE1 8 kHz	TE1 8 kHz
18	MSI/TONE	Input	8 kHz	8 kHz
19	CCI/XTAL _{in}	Input	CCI 4.096 MHz	CCI 4.096 MHz
20	TDC-RDC/ XTAL _{out}	Input	TDC-RDC Data Clk	TDC-RDC Data Clk
21	LI SENS/ 2.048 MHz	Input	Digital In Sensitivity	Digital In Sensitivity
22	RE1/ CLKOUT	Input	RE1 8 kHz	RE1 8 kHz
23	RE2/BCLK	Input	RE2 8 kHz	RE2 8 kHz
24	Rx	Input	128 kbps Data In	128 kbps Data In
25	LO2	Output	Modulator Out	LO2 = 0
26	LO1	Output	Modulator Out	LO1 = 0
27	MASTER/ SLAVE	Input	0	0
28	V _{DD}	Power	+V	+V

* Tx is high impedance when TE1 and TE2 are both low, simultaneous
Tx is undefined when TE1 and TE2 are both high, simultaneously.

data buffer with data from the Rx pin on the next eight falling edges of the TDC-RDC clock. The RE1 and RE2 enables should be roughly leading edge aligned with the TDC-RDC data clock. These enables are rising edge sensitive and need not be high for the entire B channel input period.

Slave Mode (CLKOUT UDLT-2): This pin serves as a buffered output of the crystal frequency divided by two.

RE2/BCLK

Receive Data Enable Input 2 or B Channel Data Clock Output (Pin 23)

Master Mode (UDLT-1): This pin is high impedance.

Master Mode (RE2 UDLT-2): See pin description for RE1 (pin 22).

Slave Mode (BCLK UDLT-1 and UDLT-2):

This output provides the data clock for the telset codec-filter. This clock signal is 128 kHz and begins operating upon the successful demodulation of a burst from the master. At this time, EN1-TE1 goes high and BCLK starts toggling. BCLK remains active for 16 periods, at the end of which time it remains low until another burst is received from the master. In this manner, synchronization between the master and slave is established and any clock slippage is absorbed each frame. If TONE (pin 18) is brought high, then EN1-TE1/RE1 are generated from an internal oscillator until TONE is brought low, or an incoming burst from the master is received. BCLK is disabled when \overline{LB} is held low.

Rx

Receive Data Input (Pin 24)

Master Mode (UDLT-1): The 8-bit B channel data is clocked into the device on this pin, on the falling edges of TDC-RDC, under the control of RE1.

Slave Mode (UDLT-1): The 8-bit B channel data from the telset PCM codec-filter is input on this pin on the eight falling edges of BCLK after RE1 goes high, when EN2-TE2/SIE/B1B2, pin 16 is low. When EN2-TE2/SIE/B1B2, pin 16 is high, the receive data word is latched in during the high period of EN1-TE1, pin 17

FRAME 10/20 (Pin 8)

The UDLT series of transceivers are designed to operate using a ping-pong transmission scheme with an 8 kHz burst rate. Each frame the master device “pings” a burst of data to the slave, which responds with a “pong” burst of data. This pin selects whether this 8 kHz frame will have a 10-bit data burst for UDLT-1 compatibility or a 20-bit data burst for UDLT-2 compatibility.

A logic low (0 V) selects the UDLT-1 (MC145422/MC145426) mode. This sets the device to operate with one 64 kbps voice/data channel and two 8 kbps signaling channels. A logic high (V_{DD}) on this pin selects the UDLT-2 (MC145421/MC145425) mode. This sets the device to operate with two 64 kbps channels and two 16 kbps channels (2B+2D).

SDCLK

D Channel Signaling Data Clock Input (Pin 9)

Master Mode (UDLT-2): This is the transmit and receive data clock input for both D channels. See SDO1 and SDO2 pin descriptions for more information.

Master Mode (UDLT-1): High impedance.

Slave Mode (UDLT-2): This is the transmit and receive data clock output for both D channels. It starts on demodulation of a burst from the master device. This signal is rising-edge aligned with the EN1 and BCLK signals. After the demodulation of a burst, the SDCLK line completes two cycles and then remains low until the next burst from the master is demodulated. In this manner, synchronization with the master is established and any clock slip between master and slave is absorbed each frame.

Slave Mode (UDLT-1): This pin outputs 8 kHz equivalent to TE1.

SDO1 and SDO2

D Channel Signaling Data Outputs 1 and 2 (Pins 10 and 11)

Master Mode (UDLT-2): These serial outputs provide the 16 kbps D channel signaling information from the incoming burst. Two data bits should be clocked out of each of these two outputs between the rising edges of the MSI frame reference clock. The rising edge of MSI produces the first bit of each D channel on its respective pin. Circuitry then searches for a negative D channel clock edge. This

250 μ s have elapsed without a burst from the master being successfully demodulated. This allows the slave device to self power-up and power-down in demand powered loop systems. When held low, the device powers down and the only active circuitry, is that which is necessary for the demodulation of data. When held high, the device is powered up and transmits normally in response to received bursts from the master.

MOD TRI/SQ Modulation Select (Pin 14)

A logic low (0 V) on this pin selects the MDPSK modulation which has a slow controlled voltage output for reduced EMI/RFI. This output looks like a triangle waveform that is modulated with different angles for the peaks. A logic high (V_{DD}) on this pin, selects square wave output for maximum power to the line.

Tx Transmit Data Output (Pin 15)

Master Mode (UDLT-1): This pin is high impedance when TE1 is low. When TE1 is high, this pin presents new 8-bit B channel data on rising edges of TDC-RDC.

Slave Mode (UDLT-1): B channel data is output on this pin on the rising edge of BCLK, while TE1 is high. This pin is high impedance when TE1 is low.

Master Mode (UDLT-2): This pin is high impedance when both TE1 and TE2 are low. This pin serves as an output for B channel information received from the slave device. The B channel data is under control of TE1 and TE2 and TDC-RDC.

Slave Mode (UDLT-2): This pin is an output for the B channel data received from the master. B channel 1 data is output on the first eight cycles of the BCLK output when EN1 is high. B channel 2 data is output on the next eight cycles of the BCLK, when EN2 is high. B channel data bits are clocked out on the rising edge of the BCLK output pin.

EN2-TE2/SIE/B1B2 B Channel 2 Enable Output or Signal Insert Enable (Pin 16)

Master Mode (SIE UDLT-1): In this mode, this pin functions as SIE. When held high, this pin causes signal bit 2, as received from the slave, to be inserted into the LSB of the outgoing PCM word at the Tx pin. The SDI2 pin will be ignored, and in its place, the LSB

pin is also updated on the rising edge of the EN1 signal.

MSI/TONE Master Sync Input or Tone Enable Input (Pin 18)

Master Mode (MSI): This pin is the master 8 kHz frame reference input. The rising edge of MSI loads B and D channel data, which had been input during the previous frame, into the modulator section of the device, and initiates the outbound burst onto the twisted pair cable. The rising edge of MSI also initiates the buffering of the B and D channel data demodulated during the previous frame. MSI should be approximately leading edge aligned with the TDC-RDC data clock input signal.

Slave Mode (TONE): A high on this pin causes a 500 Hz square wave PCM tone to be inserted in place of the demodulated data. This feature allows the designer to provide audio feedback for telset keyboard depressions.

CCI/XTAL_{in} Convert Clock Input or Crystal Input (Pin 19)

Master Mode (CCI UDLT-1): A 2.048 MHz clock signal should be applied to this pin. This signal is used for internal sequencing and control. This signal should be frequency and phase coherent with MSI for optimum performance.

Slave Mode (XTAL_{in} UDLT-1): A 4.096 MHz crystal is tied between this pin and XTAL_{out} (pin 20). A 10 M Ω resistor across this pin and XTAL_{out} and 25 pF capacitors from this pin and XTAL_{out} to V_{SS} are required for stability and to ensure start-up. This pin may be driven from an external source. XTAL_{out} should be left open if an external signal is used on this input.

Master Mode (CCI UDLT-2): An 8.192 MHz clock should be supplied to this input. The 8.192 MHz input should be 50% duty cycle. This signal may free run with respect to all other clocks without performance degradation.

Slave Mode (XTAL_{in} UDLT-2): Normally, an 8.192 MHz crystal is tied between this pin and the XTAL_{out} (pin 20). A 10 M Ω resistor between XTAL_{in} and XTAL_{out} and 25 pF capacitors from XTAL_{in} and XTAL_{out} to V_{SS} are required to ensure stability and start-up. XTAL_{in} may also be driven with an external 8.192 MHz signal if a crystal is not

DT SI
TSSOP P
CASE 1

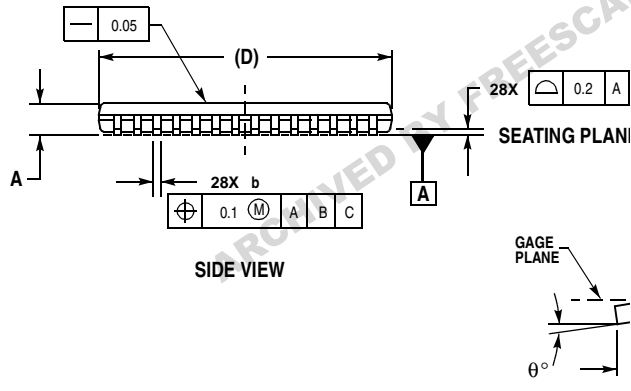
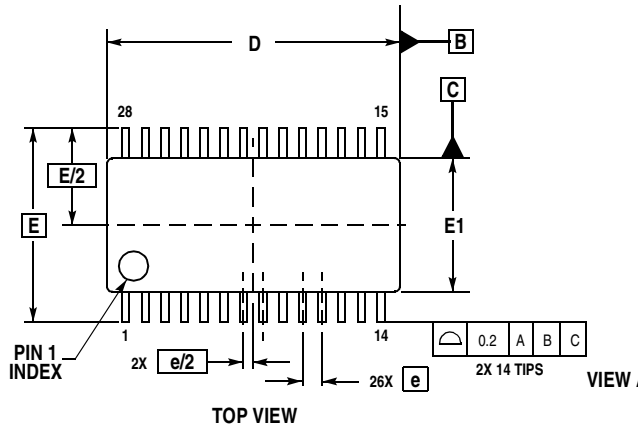

BASIC DIGITAL TELSET

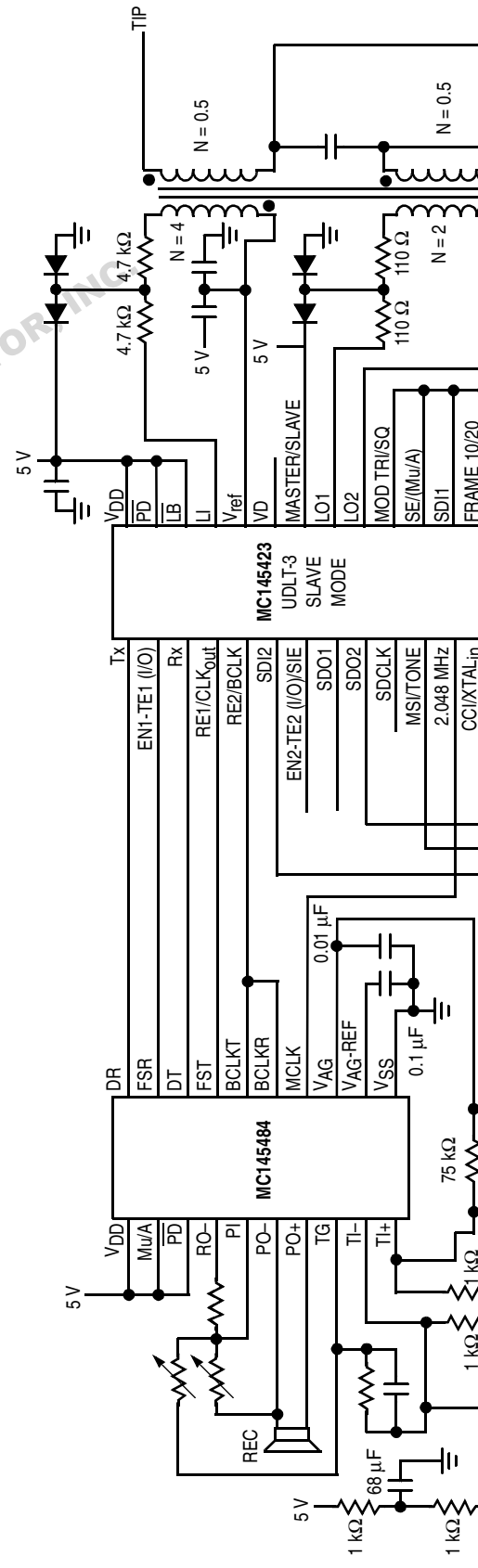

MULTICHANNEL D

PACKAGE D

DW S
SOIC PA
CASE 7

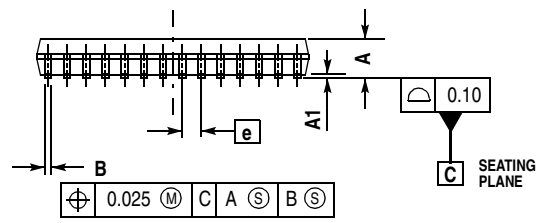
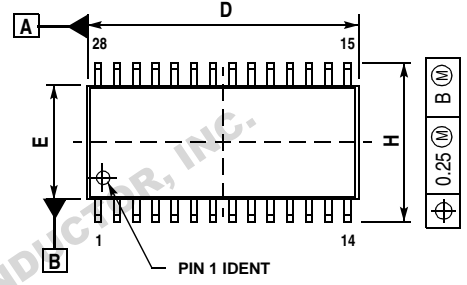
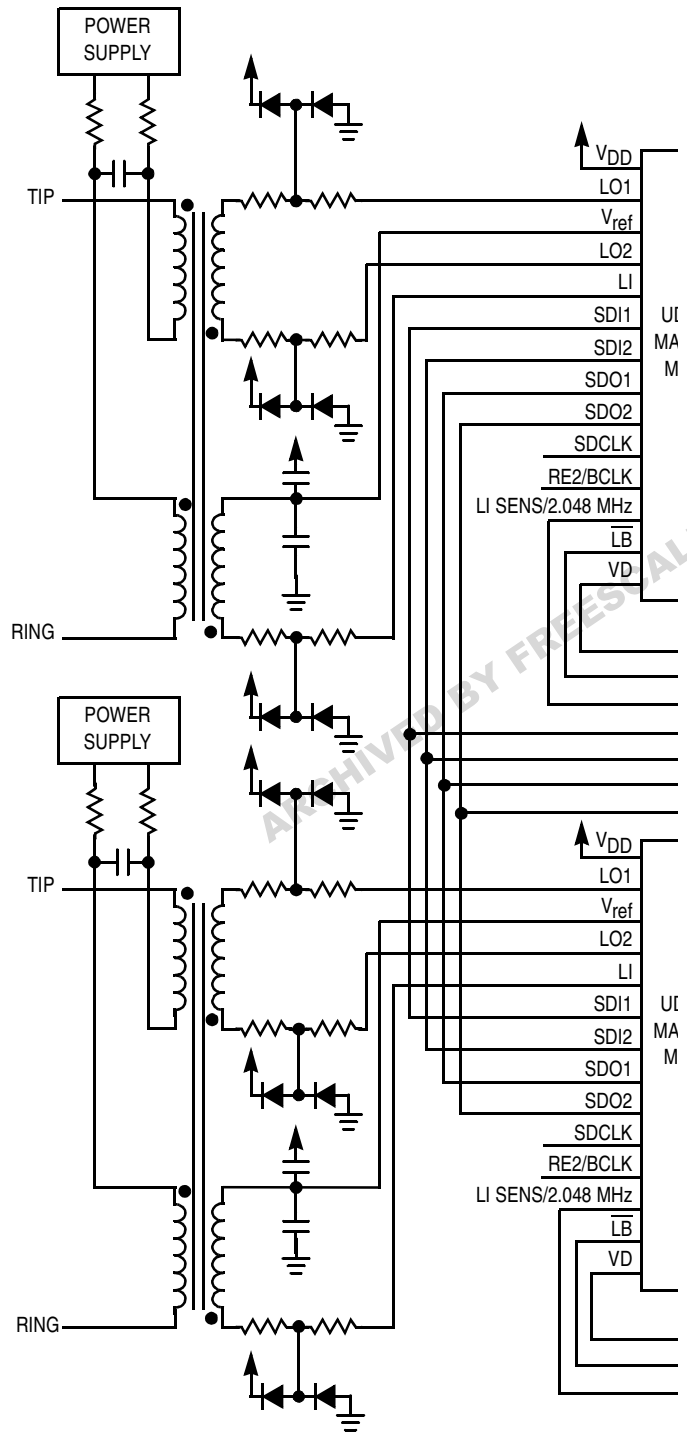



ARCHIVED BY FREESCALE SEMICONDUCTOR, INC.

Digital DNA is a trademark of Motorola, Inc.

Motorola reserves the right to make changes without further notice to guarantee regarding the suitability of its products for any particular application or use of any product or circuit, and specifically disclaim incidental damages. "Typical" parameters can and do vary in different parameters, including "Typicals", must be validated for each customer convey any license under its patent rights nor the rights of others. Motorola components in systems intended for surgical implant into the body, or application in which the failure of the Motorola product could create purchase or use Motorola products for any such unintended or unauthorized officers, employees, subsidiaries, affiliates, and distributors harmless attorney fees arising out of, directly or indirectly, any claim of personal even if such claim alleges that Motorola was negligent regarding the trademarks of Motorola, Inc. Motorola, Inc. is an Equal Opportunity/Affirmative Action Employer.

How to reach us:

USA/EUROPE/Locations Not Listed: Motorola Literature Distribution
1-303-675-2140 or 1-800-441-2447

JAPAN: Motorola Japan Ltd.; SPS, Technical Information Center, 3-21-1
81-3-3440-3569

ASIA/PACIFIC: Motorola Semiconductors H.K. Ltd.; Silicon Harbour Center
Hong Kong. 852-26668334

TECHNICAL INFORMATION CENTER: 1-800-521-6274

HOME PAGE: <http://motorola.com/semiconductors/>



MOTOROLA

**For More Information On This Product,
Go to: www.freescale.com**