

SERIES 67C

Hall Effect Joystick with Integrated Pushbutton & Optical Encoder

FEATURES

- Proportional joystick, pushbutton & optical encoder functions from a single shaft
- Analog joystick outputs are proportional to angle of shaft deflection
- Long life, high reliability
- Choices of cable length and termination
- Customized solutions available

APPLICATIONS

- Global positioning / Driver information systems
- Entertainment equipment
- Medical equipment controls
- Radio control belly boxes
- Robotics
- Aerospace
- Avionics
- Security camera controls



DIMENSIONS in inches

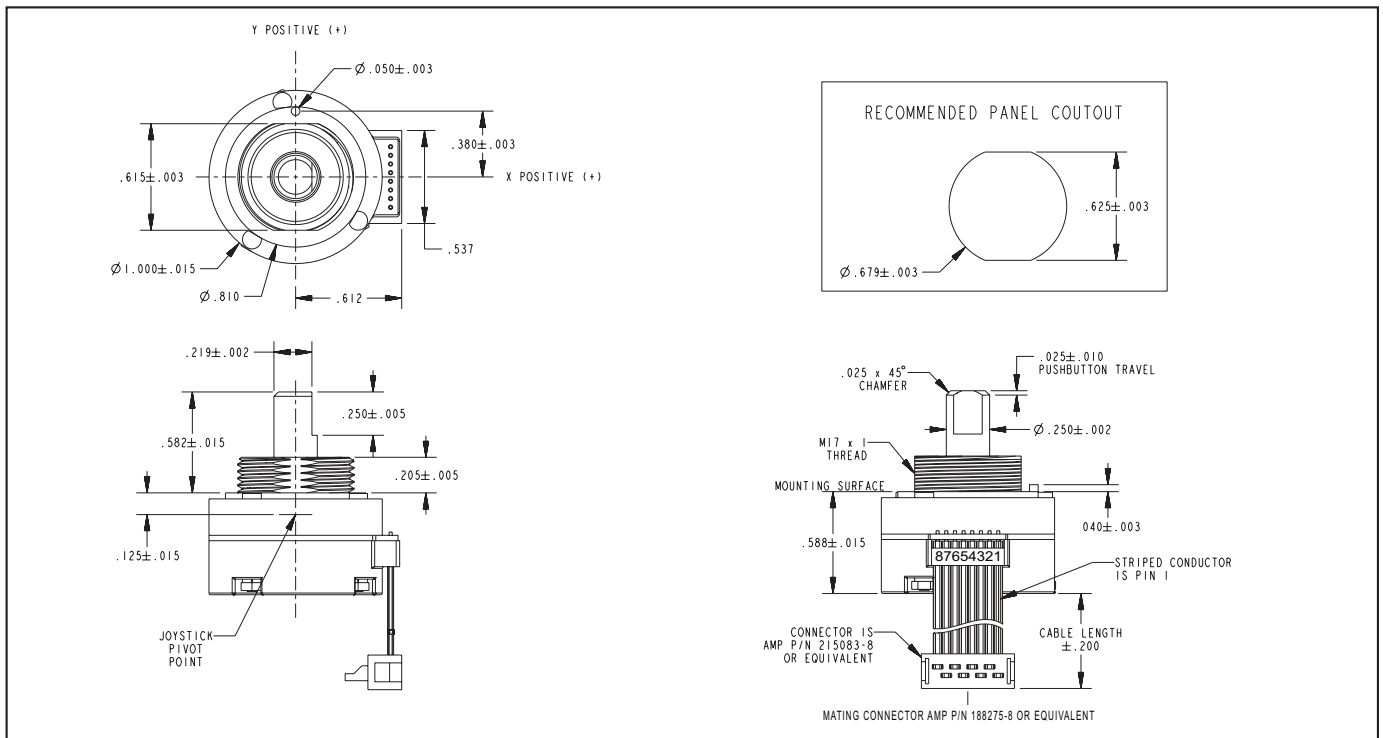

JOYSTICK OUTPUT WAVEFORM

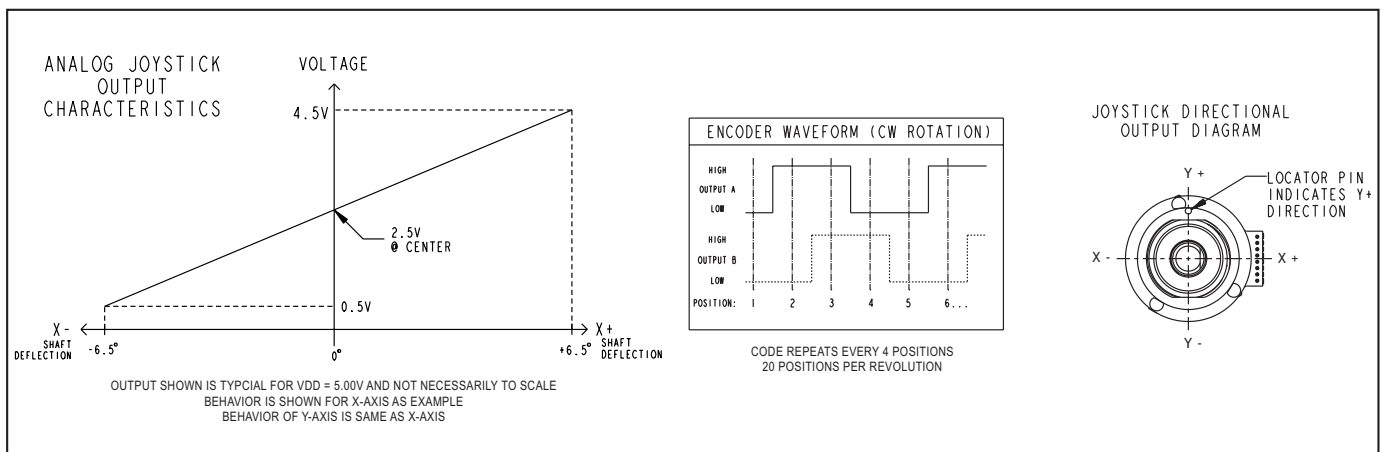



Joysticks

SPECIFICATIONS

General Electrical Specifications

Operating Voltage on Pin 6 (VDD): 5.0 ± 0.25V

Absolute Maximum Voltage* on Pin 6 (VDD): -0.3 V min, 6.5 V max.

Operating Current: 8 mA typ., 12 mA, max.

Joystick Electrical and Mechanical Ratings

Sensing Method: Hall effect, proportional to angle of deflection

Output Voltage (Pins 7 & 8): Analog (Ratio-metric to Operating Voltage)

Output at Center Position: 50% VDD

Output at Full Travel:

10% VDD (for X-, Y- directions)

90% VDD (for X+, Y+ directions)

Output Tolerance: ± 2% VDD (at Center and at Full Travel)

Output Current: 200 µA, max.

Angle of Throw: 6.5° + 2° / -1° in main directions; 9.0° ± 0.1° in diagonals

Life: 500,000 actuations in each of the four main directions

Pushbutton Electrical and Mechanical Ratings

Rating: 10 mA at 5 Vdc resistive

Absolute Maximum Voltage* on Pins 2 & 3: 6.0 V

Contact Resistance: less than 10 ohms

Life: 1 million actuations minimum

Contact Bounce: < 4 mS make, < 10 mS break

Actuation Force: 960 ± 150 grams (700

grams Dome)

Pushbutton Travel: 0.025 ± 0.010 inches

Rotary Electrical and Mechanical Ratings

Output Code (Pins 4 & 5): 2-Bit quadrature: Channel "A" leads channel "B" by 90° electrically during clockwise rotation of the shaft

Output Type: Push/Pull

Output Low Voltage: 0.6V maximum for IOL = 2 mA.

Output High Voltage: 4.3V minimum for IOH = -1.5 mA, (VDD = 5.0V)

Mechanical Life: 1 million rotational cycles of operation (1 cycle is a rotation through all positions and a full return)

Mounting Torque: 15 in-oz maximum

Shaft Push-Out Force: 45 lbs minimum

Shaft Pull-Out Force: 45 lbs minimum

Solderability: 95% free of pin holes and voids

Detents: 20 Position

Torque: Initially 3.5 ± 1.5 in-oz average of all positions, with a 1.5 in-oz maximum range (Max position - Min position) = Range

After 1 million cycles, average torque shall not change by more than 50% of the initial value

Soldering Recommendation

Hand solder only per IPC J-STD-001

Environmental Ratings

Operating Temperature Range: -40°C to 85°C

Storage Temperature Range: -55°C to

100°C

Relative Humidity: 96 hours at 90-95% humidity at 40°C

Vibration: Harmonic motion with amplitude of 15g, within a varied 10 to 2000 Hz frequency for 12 hours

Mechanical Shock:

Test 1: 100g for 6ms half-sine wave with a velocity change of 12.3 ft/s

Test 2: 100g for 6ms sawtooth wave with a velocity change of 9.7 ft/s

Materials and Finishes

Pin Header: Terminals: Phosphor bronze; Insulator: Nylon 4/6; Plated with tin

Cable: Copper stranded with silver plating in PVC insulation, 28 AWG

Connector: Nylon 4/6; 30% Glass-filled; Tin-plated phosphor bronze terminals

Mounting Nut: Polyurethane

Shaft: Thermoplastic

ROHS Compliant.

EMC Ratings

Radiated Immunity: Passed 10 V/m: 80-2700 MHz per IEC 61000-4-3

Conducted Immunity: Passed 10 V/m: 0.15 80 MHz per IEC 61000-4-6

Radiated Emissions: Passed EN 55022 Class B

Conducted Emissions: Passed EN 55022 Class B

Electrostatic Discharge: Passed 15kV contact/25kV air discharge per IEC 61000-4-2

Power Frequency Magnetic Field: Passed 30 A/m per IEC 61000-4-8

* Exceeding the Absolute Maximum Voltage may result in permanent damage to the device. This is a stress rating only and functional operation of the device at those or any other conditions above those indicated in the operation listings of this specification is not implied.

Joysticks

ORDERING INFORMATION

CABLE LENGTH

020 = 2"

040 = 4"

060 = 6"

2" Increments

Leave blank if choosing pin header

Examples:

67C18-8-M-020 = 2.0" cable with connector

67C18-8-M-P = Pin header

JOYSTICK DIRECTIONS
8 = 4 Sensors, 8 Directions
(No Gating)

67CXX-X-X-XXXX

FORCE OPTION
M = Medium Forces

ROTATIONAL ENCODER RESOLUTION

18 = 18°, 20 positions

08 = Non-detent, 20 positions

00 = Non-turn

TERMINATION

S = Stripped Cable

C = Cable with Connector

P = Pin Header

BLOCK DIAGRAM

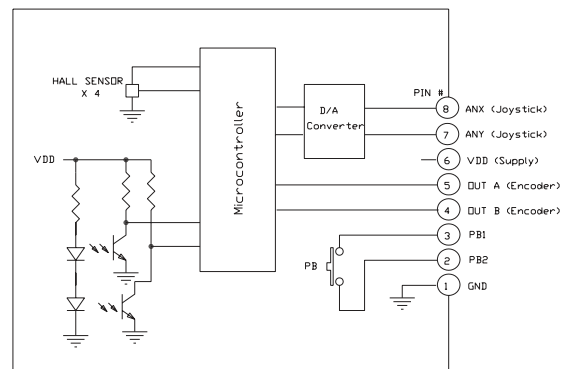

For prices and custom configurations, contact a local sales office, an authorized distributor, or Grayhill's sales department.