

Rev	AWO #	Description	Date	Appr
-		RELEASED	11/16/18	

APPROVED: _____
DATE: _____ TITLE: _____

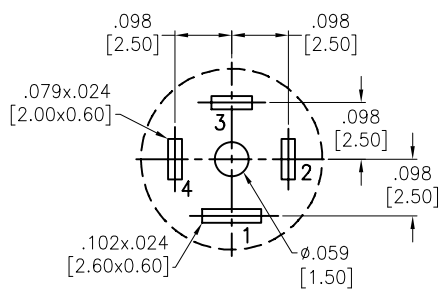

RECOMMENDED PCB LAYOUT
(COPPER SIDE VIEW)

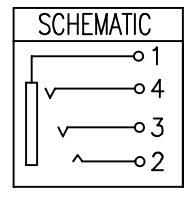
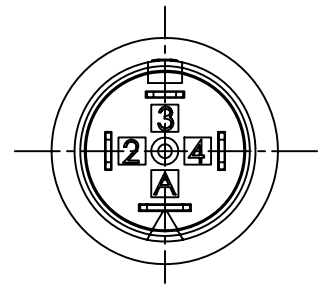
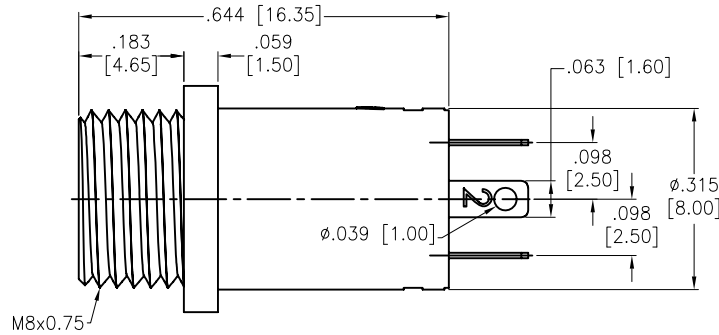
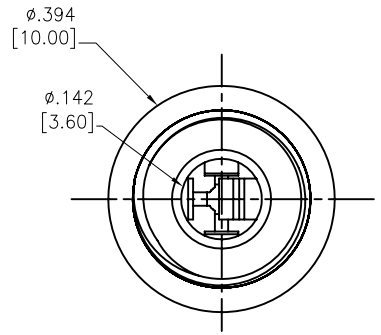
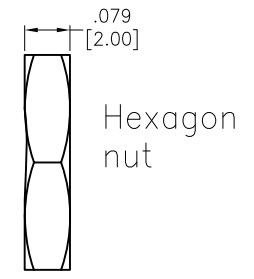
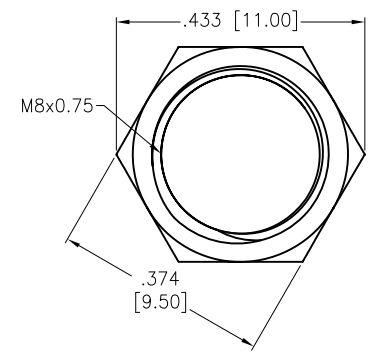
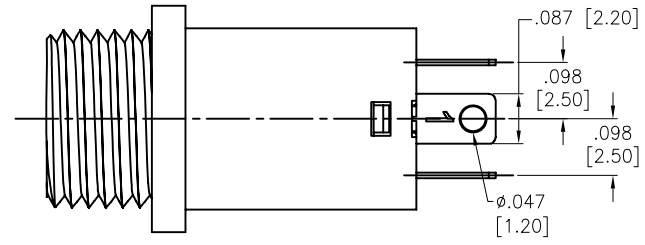

Hexagon nut

ADAM P/N	NUT TYPE
ASJ-165-M-G-HDW-1	Hexagon
ASJ-165-M-G-HDW-2	Round

SPECIFICATIONS:
Material:
Insulator: PA66, rated UL 94V-0
Insulator color: Black
Contact: Phosphor Bronze
Nut: Brass, Nickel plated
Plating:
Gold flash over Nickel underplate overall
Electrical:
Rating: 30 VDC, 0.5 A
Contact resistance: 30 mohms max
Insulation resistance: 100 Mohms min @ 500 VDC
Dielectric withstanding voltage: 500 VAC
Temperature Rating:
Operating temperature: -20°C to +70°C
Environmental:
Lead free, RoHS compliant.

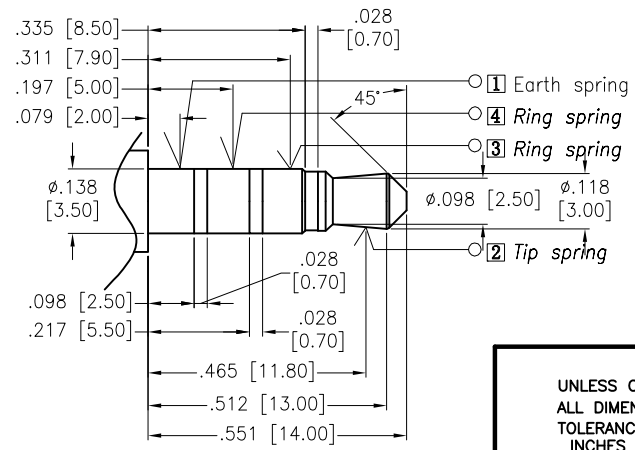

MATE PLUG

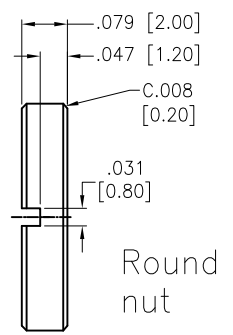
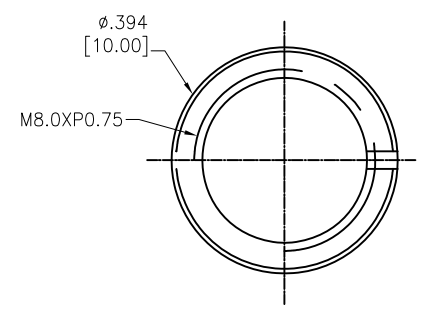

Round nut

UNLESS OTHERWISE SPECIFIED
ALL DIMENSIONS ARE INCHES [MM]
TOLERANCES: EXCEPT AS NOTED
INCHES HOLES

.X ± .10	Ø.X ± .10
.XX ± .020	Ø.XX ± .015
.XXX ± .015	Ø.XXX ± .010

ADAM TECH INTERCONNECTS
909 Rahway Avenue,
Union, NJ 07083
Phone: 908-687-5000
Fax: 908-687-5710

APPROVALS		DATE
DRAWN	HR	11/16/18
CHECKED	AC1	11/16/18
APPROVED		

TITLE		
3.5MM PHONE JACK, GOLD PLATED		
SIZE	PART NO.	REV.
X	ASJ-165-M-G-HDW-X	-
REF:	S00002C	SCALE: NTS SHEET 1 OF 1

