

RIGHT ANGLE FEMALE CONNECTOR

R201.151.000

SOLDER CABLE .047

Series : **SMPM**

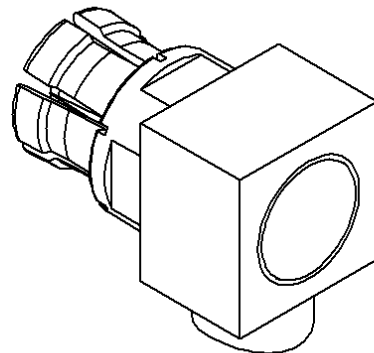
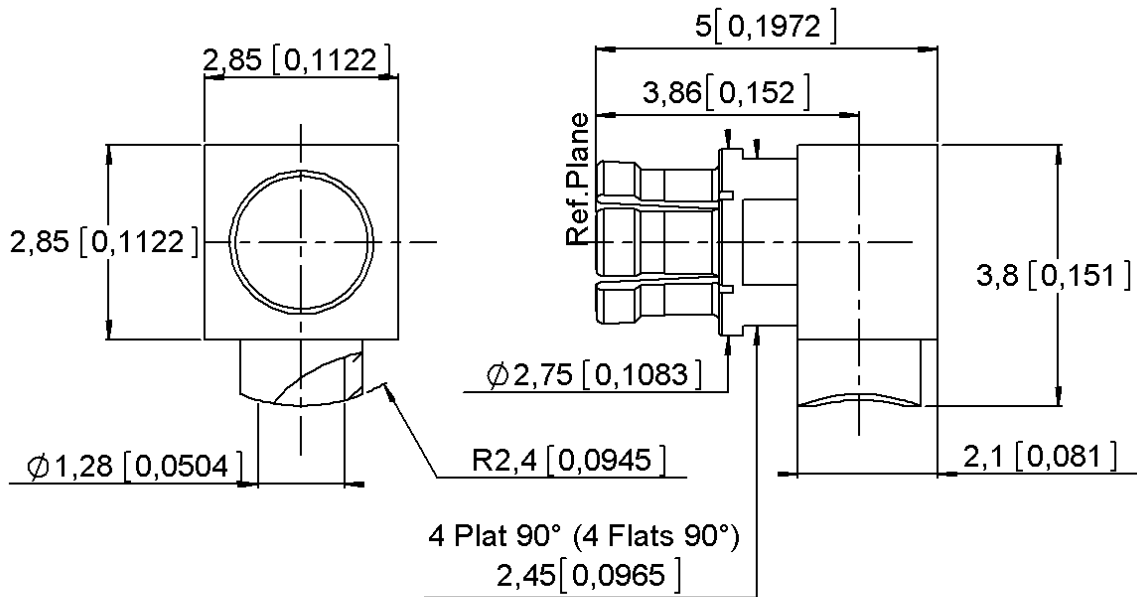

Scale : 1/1

All dimensions are in mm.

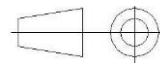

COMPONENTS	MATERIALS	PLATING (μm)
BODY	BERYLLIUM COPPER	GOLD 1.3 OVER NICKEL2
CENTER CONTACT	BERYLLIUM COPPER	GOLD 1.3 OVER NICKEL2
OUTER CONTACT	-	-
INSULATOR	PEEK	-
GASKET	-	-
OTHERS PARTS	BRASS	GOLD 1.3 OVER NICKEL2
-	-	-
-	-	-

Issue : 16-02-15A

In the effort to improve our products, we reserve the right to make changes judged to be necessary.



RIGHT ANGLE FEMALE CONNECTOR

R201.151.000

SOLDER CABLE .047

Series : **SMPM**

PACKAGING

Standard	Unit	Other
100	'W' option	Contact us

SPECIFICATION

ELECTRICAL CHARACTERISTICS

Impedance	50	Ω
Frequency	0-18	GHz
VSWR	*1.3 + 0,0000	x F(GHz) Maxi
Insertion loss	0.12	\sqrt{F} (GHz) dB Maxi
RF leakage	- (NA)	- F(GHz)) dB Maxi
Voltage rating	335	Veff Maxi
Dielectric withstanding voltage	500	Veff mini
Insulation resistance	5000	M Ω mini

CABLE ASSEMBLY

Stripping	a	b	c	d	e	f
mm	1,60	0,00	0,00	0,00	0,00	0,00

Assembly instruction :

Recommended cable(s)
UT47 M17/151-00001

MECHANICAL CHARACTERISTICS

Center contact retention		
Axial force – Mating end	6.7	N mini
Axial force – Opposite end	6.7	N mini
Torque	NA	N.cm mini

Characteristics indicated on this data sheet are those that can be achieved with the highest performance cable. Intrinsic limitations of the cable may diminish the performance of the assembly

Cable retention

- pull off	45	N mini
- torque	NA	N.cm

TOOLING

Recommended torque		
Mating	NA	N.cm
Panel nut	NA	N.cm
Clamp nut	NA	N.cm
A/F clamp nut	0,0000	mm

Part Number	Description	Hexagon
R282740020	SOLDERING MOUNTING	

Mating life	500	Cycles mini
Weight	0,2000	g

OTHER CHARACTERISTICS

*VSWR 1.25 TO 12 GHz

ENVIRONMENTAL

Operating temperature	-40/+100	$^{\circ}$ C
Hermetic seal	NA	Atm.cm3/s
Panel leakage	NA	

Issue : **16-02-15A**

In the effort to improve our products, we reserve the right to make changes judged to be necessary.



RIGHT ANGLE FEMALE CONNECTOR
SOLDER CABLE .047

R201.151.000

Series : SMPM

COMPONENT

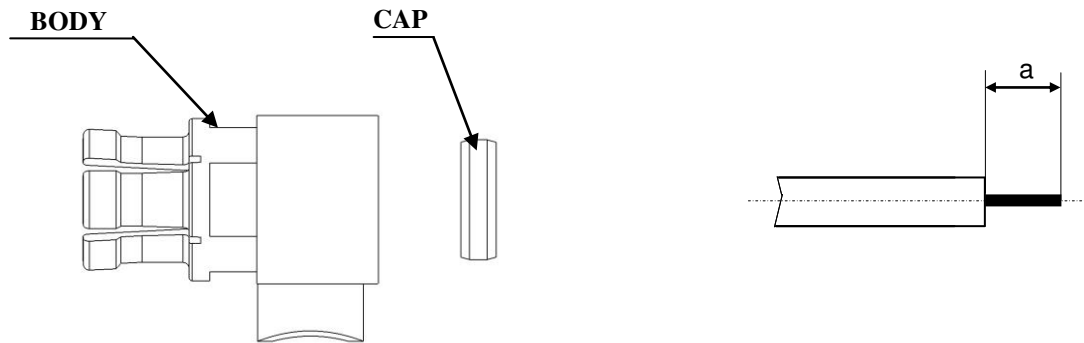

We recommend a cable thermal preconditioning before assembly

1

- Strip the cable.
- Clean the cable

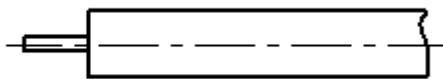

2

- Introduce the cable into the connector body until it stops.
- Place the sub assembly into the assembly and tighten it .
- Solder the body onto the cable.
- After cooling remove cable assembly from the jig.

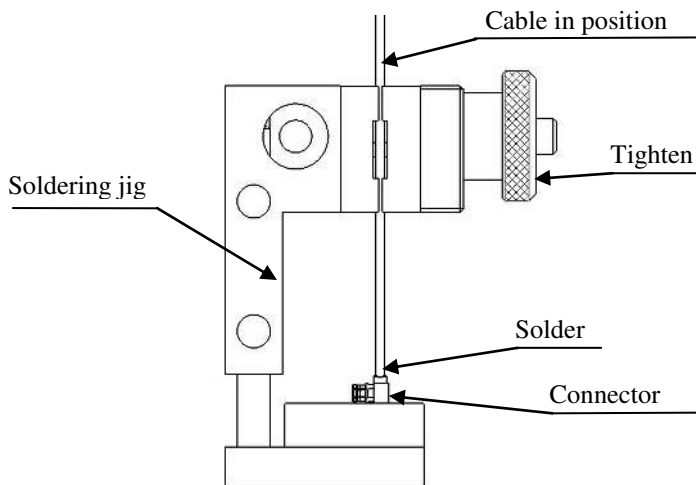

3

- Solder cable inner conductor into the centre contact.
- Clean soldering area

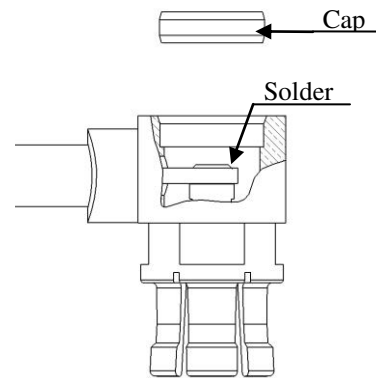

4

- Put the cap in its place.
- Press cap flush or slightly below surface of body assembly.

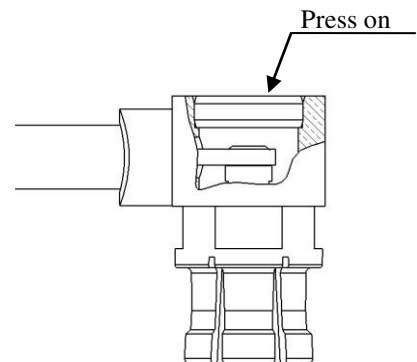

Issue : 16-02-15A

In the effort to improve our products, we reserve the right to make changes judged to be necessary.