

DIMENSIONS

POSITIONS	A		B		C		D		E		F	
	MM	INCH	MM	INCH	MM	INCH	MM	INCH	MM	INCH	MM	INCH
09	30.81	1.213	24.99	0.984	16.92	0.666	16.33	0.643	11.08	0.436	19.20	0.756
15	39.20	1.543	33.30	1.311	25.25	0.994	24.70	0.972	19.39	0.763	27.70	1.091
25	53.05	2.088	47.04	1.852	38.96	1.534	38.40	1.512	33.24	1.309	41.10	1.618
37	69.40	2.732	63.50	2.500	55.42	2.182	54.80	2.158	49.86	1.963	57.30	2.256

REVISIONS				
REV.	ECO. NO	DESCRIPTION	DATE	BY
A	2398	INITIAL RELEASE	07/01/2011	LH
B	2576	UPDATE PART NUMBER CODING	05/10/2012	LH
C	2616	REMOVE 'B' PLATING	06/14/2012	LH

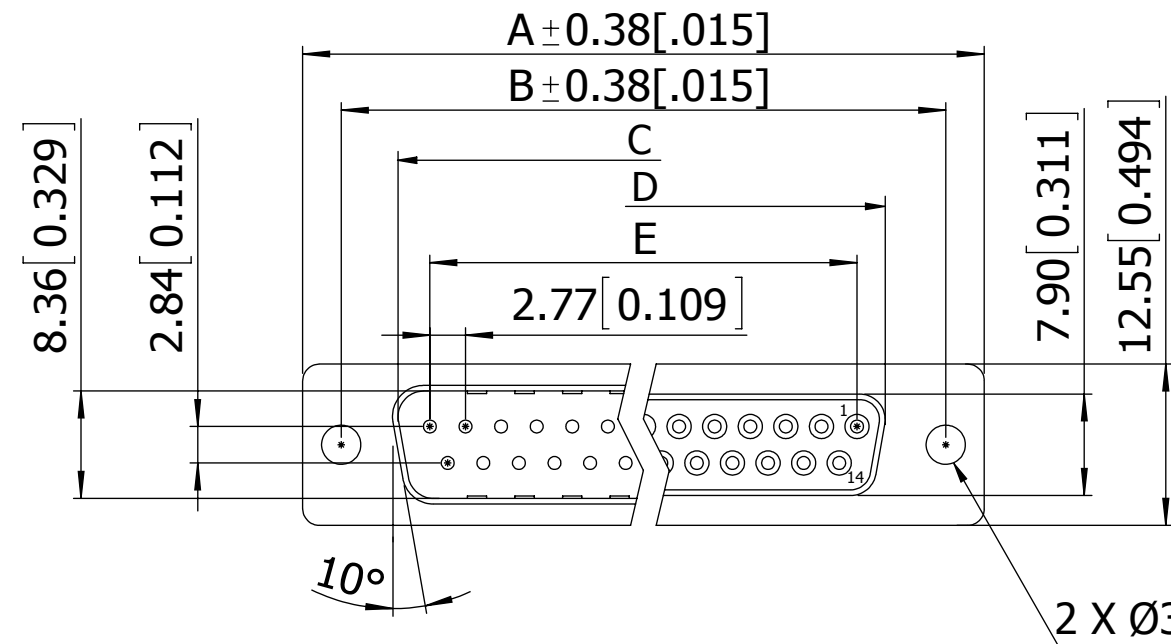

$2.84[0.112] \times 2 = 5.68[0.224]$

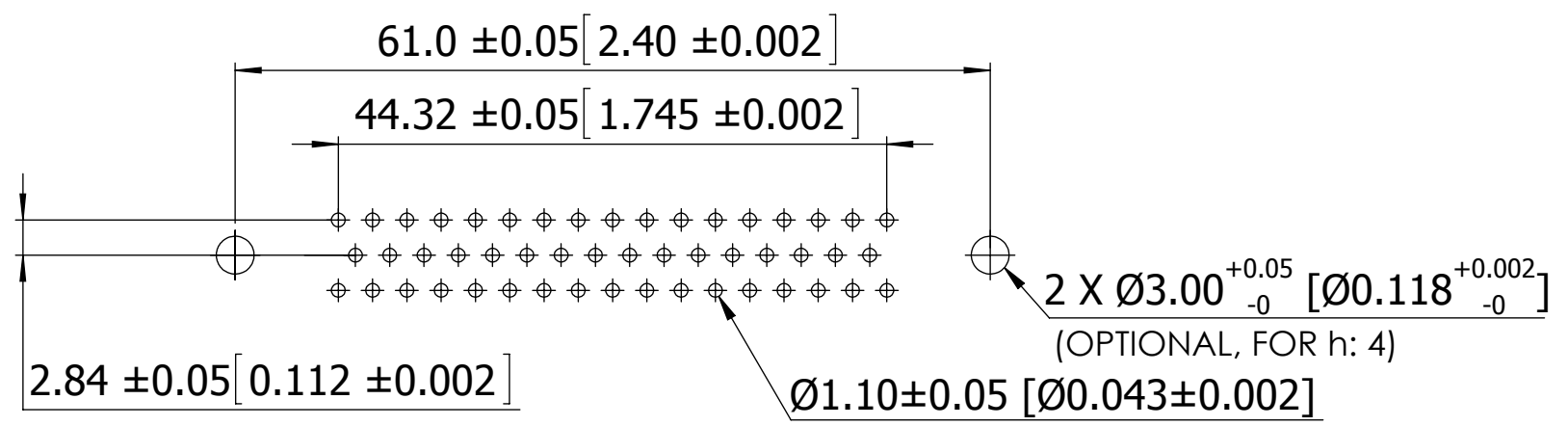
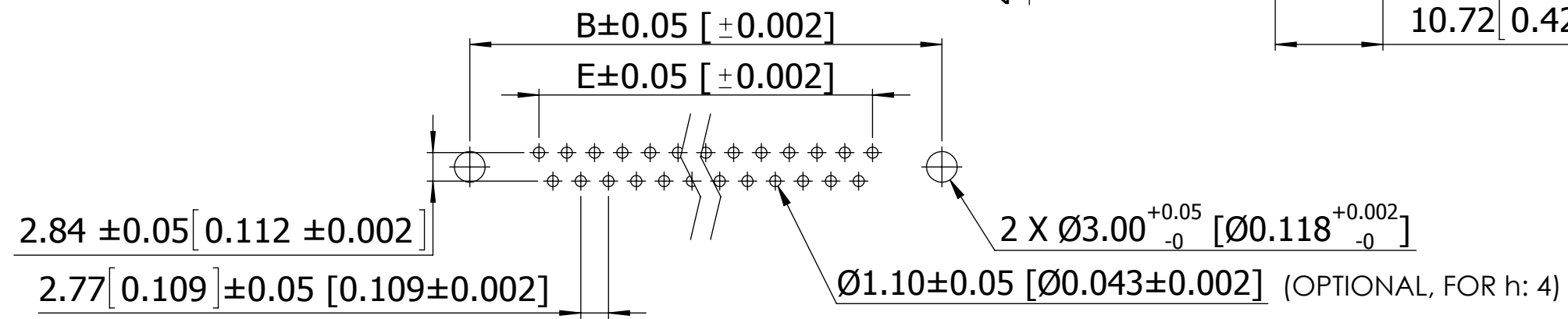
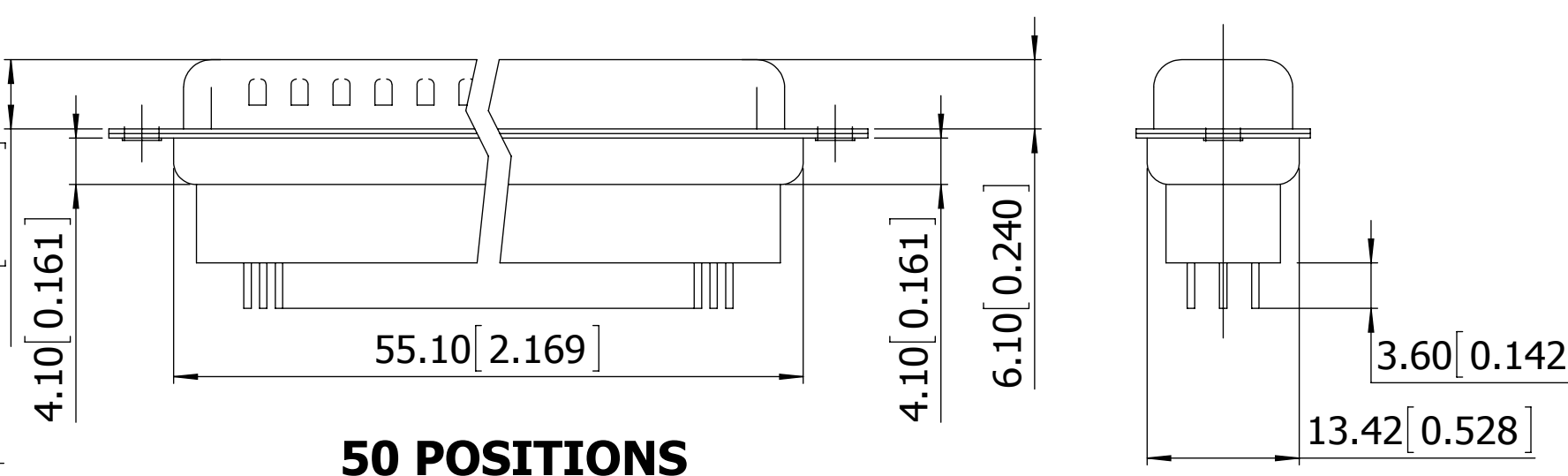
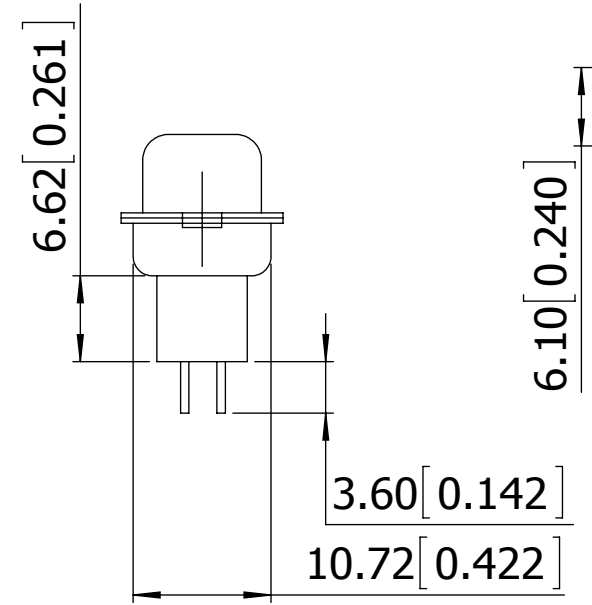
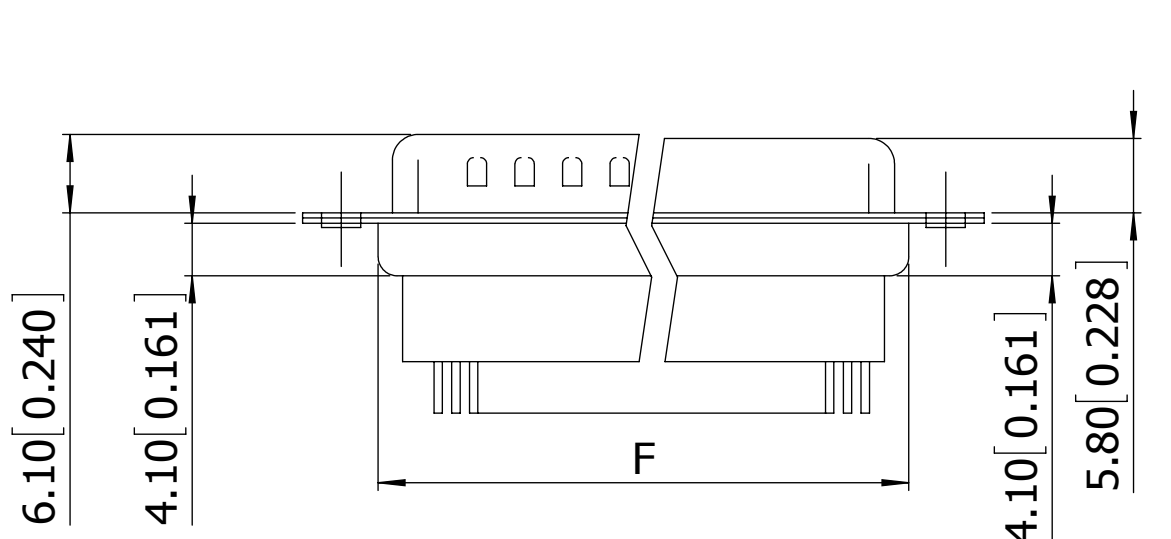
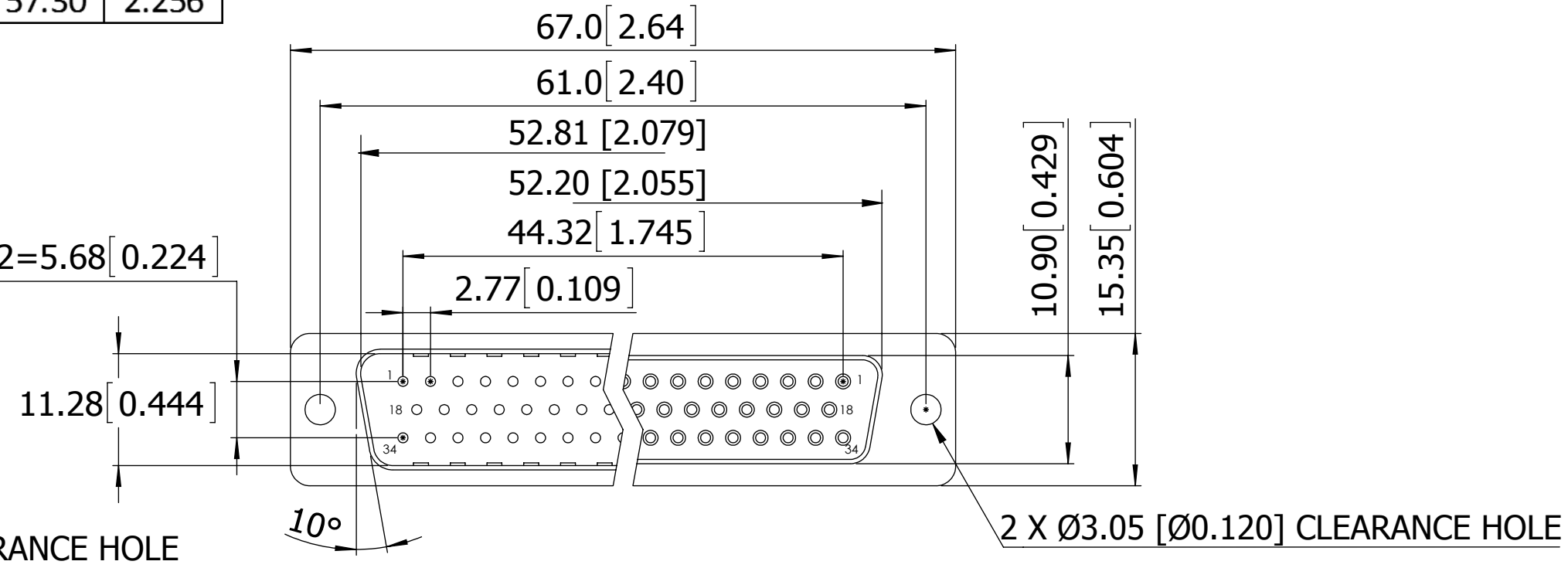

RECOMMENDED PCB LAYOUT
(PN EXAMPLE: SDS155-PRW2-M09-QN00-1)

RECOMMENDED PCB LAYOUT
50 POSITIONS
(PN EXAMPLE: SDS155-PRW2-M50-QN00-1)

- NOTES:
- MATERIAL
 - INSULATOR : GLASS-FILLED THERMOPLASTIC PBT, UL94V-0
 - CONTACT: BRASS
 - SHELL : SPCC, .000100" TIN OVER .000050" MIN. COPPER (STANDARD, SEE PAGE 3)
 - CLINCH NUT : BRASS, NICKEL PLATED
 - BOARDLOCK : BRASS, TIN PLATED
 - SCREWLOCK : STEEL, NICKEL PLATED
 - OPERATING TEMPERATURE : -55 °C TO +105 °C

- ELECTRICAL
- CONTACT RESISTANCE : 20 MILLIOHMS MAX AT 1 AMP DC
 - INSULATION RESISTANCE : 1000 MAGOHMS AT 500 VDC
 - DIELECTRIC WITHSTANDING VOLTAGE : 1000 VAC/RMS 60Hz FOR 1 MINUTE
 - CURRENT RATING : 3 AMPS
 - VOLATGE RATING : 250 VAC/RMS 60Hz



UNLESS OTHERWISE SPECIFIED: DIMENSIONS ARE IN MM [INCHES]	DRAWN	DATE	NAME	
		07/01/2011	LH	
TOLERANCES:	<small>THE INFORMATION HEREIN CONTAINS PROPRIETARY INFORMATION OF SULLINS ELECTRONICS AND IS NOT TO BE REPRODUCED, USED OR DISCLOSED TO OTHERS FOR ANY PURPOSE EXCEPT AS SPECIFICALLY AUTHORIZED IN WRITING BY AN OFFICER OF SULLINS ELECTRONICS.</small>			
ANGULAR: ± 3°	TITLE 155 SERIES D-SUB HIGH PROFILE STRAIGHT TYPE			
DECIMALS	PART NUMBER SDS155-PR _ _ - _ -QN _ _ -1			
X.= ± 0.38 [.015]	SIZE	CAGE CODE	DWG. NO.	REV
X.= ± 0.25 [.010]	C	54453	11801	C
.XX= ± 0.13 [.005]	SCALE: 1:8	SHEET 1 OF 3		

h. RIVET OPTIONS:

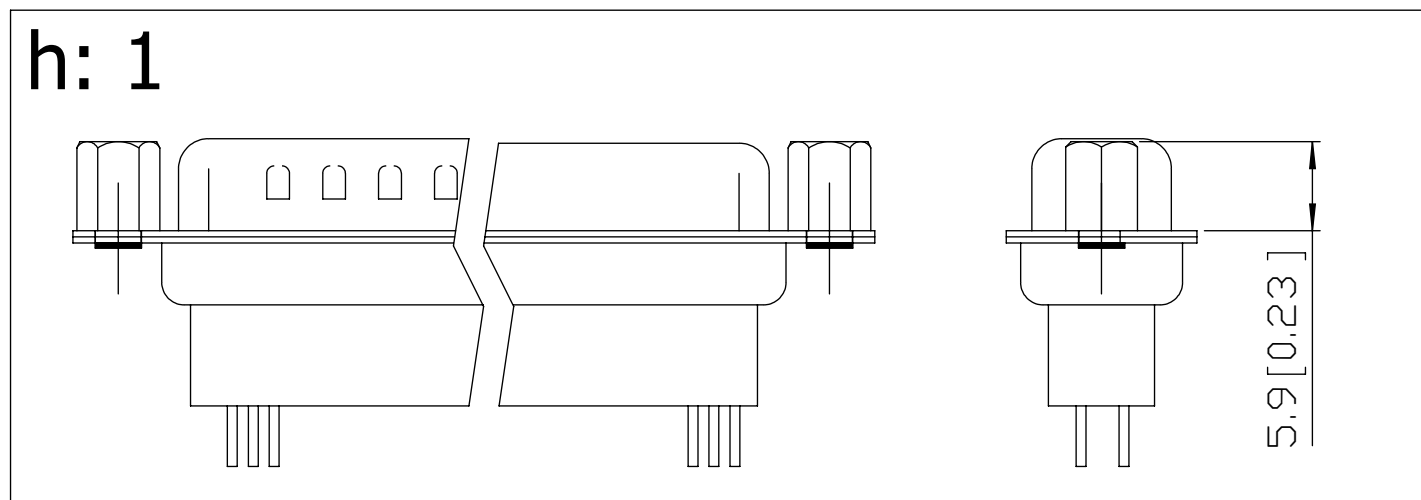
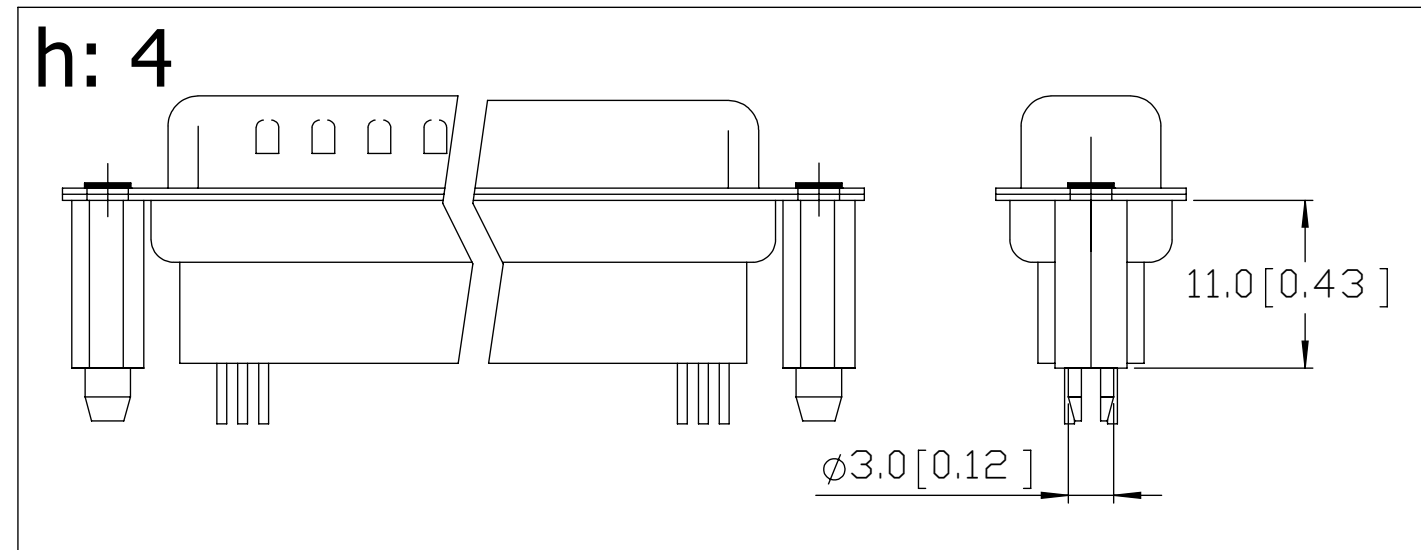
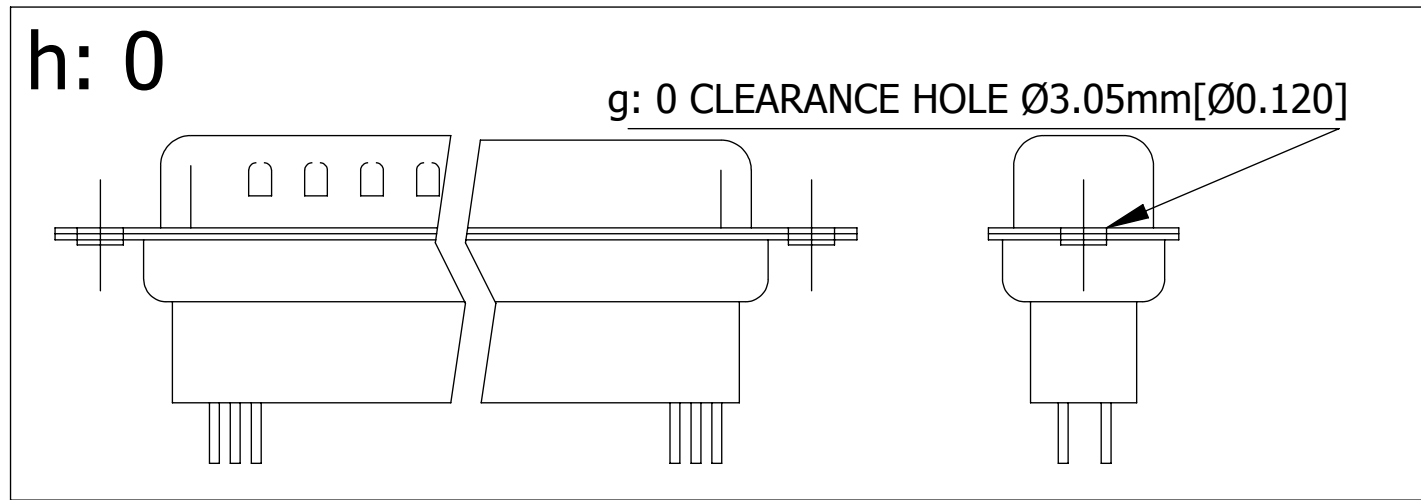

**CONSULT SALES OR
FACTORY FOR OTHER
MOUNTING STYLE OPTIONS**

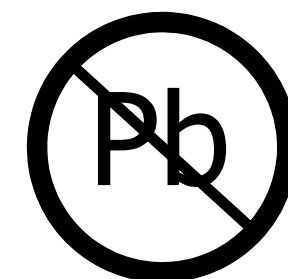
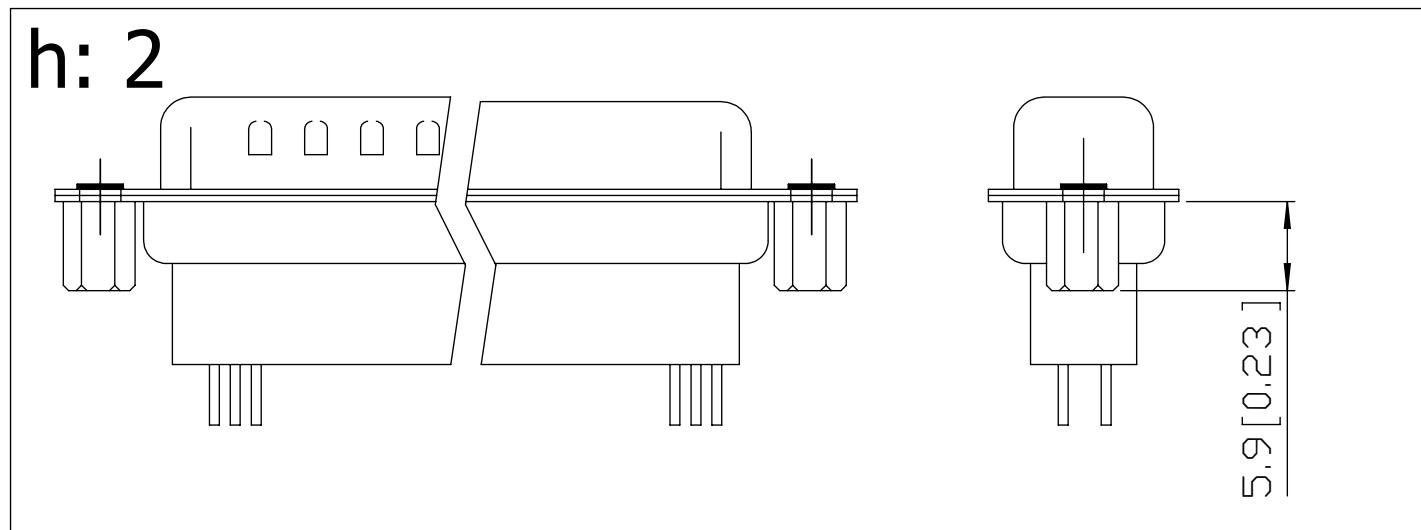

RoHS COMPLIANT

UNLESS OTHERWISE SPECIFIED: DIMENSIONS ARE IN MM [INCHES]		DRAWN	DATE	NAME	
TOLERANCES: ANGULAR: ± 3° DECIMALS X.= ± 0.38 [015] X.= ± 0.25 [010] .XX= ± 0.13 [005]			07/01/2011	LH	
THE INFORMATION HEREIN CONTAINS PROPRIETARY INFORMATION OF SULLINS ELECTRONICS AND IS NOT TO BE REPRODUCED, USED OR DISCLOSED TO OTHERS FOR ANY PURPOSE EXCEPT AS SPECIFICALLY AUTHORIZED IN WRITING BY AN OFFICER OF SULLINS ELECTRONICS.					TITLE
					155 SERIES D-SUB HIGH PROFILE STRAIGHT TYPE PART NUMBER
					SDS155-PR _ _ _ _ -QN _ _ -1
SIZE	CAGE CODE	DWG. NO.	REV		
C	54453	11801	C		
SCALE: 1:8				SHEET 2 OF 3	

SDS155-PR__ - __ - QN__ - 1

a b c d e f g h i

a. CONTACT PLATING

(ALL PLATINGS HAVE .000050" NICKEL UNDERPLATE)

W = GOLD FLASH ON CONTACT SURFACE,
.000100" PURE TIN ON TERMINATION.

U = .000015" GOLD ON CONTACT SURFACE,
.000100" PURE TIN ON TERMINATION.

C = .000030" GOLD ON CONTACT SURFACE,
.000100" PURE TIN ON TERMINATION.

b. SHELL PLATING

1 = NICKEL
2 = TIN (STANDARD)

c. CONTACT TYPE

M = MALE
F = FEMALE

d. NO. OF CONTACTS

09 = 09 POSITIONS
15 = 15 POSITIONS
25 = 25 POSITIONS
37 = 37 POSITIONS
50 = 50 POSITIONS

e. PIN TYPE

Q = STAMPED PIN, TAIL LENGTH = 3.6mm [0.14]

f. FERRITE

N = WITHOUT FERRITE

g. FLANGE MOUNTING OPTION

0 = Ø3.05mm [Ø0.120] CLEARANCE HOLE

1 = #4-40 FEMALE THREAD

8 = #4-40 UNC (5.0 X 10.0 mm [0.20 X 0.39]) FEMALE SCREWLOCK INSTALLED

9 = #4-40 UNC (5.0 X 10.0 mm [0.20 X 0.39]) FEMALE SCREWLOCK BULK-PACKED

h. RIVET OPTIONS

0 = Ø3.05 mm [Ø.120] CLEARANCE HOLE

1 = FRONT RIVET, 5.9 mm [0.23]

2 = REAR RIVET, 5.9 mm [0.23]

4 = STANDOFF + 2 PRONG BOARDLOCK Ø3.0 X 11.0 L [0.12 X 0.43]

i. INSULATOR COLOR

1 = BLACK (STANDARD)

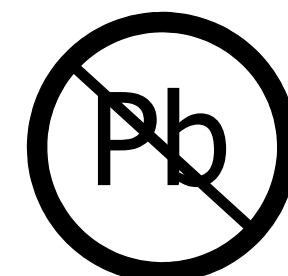

RoHS COMPLIANT

UNLESS OTHERWISE SPECIFIED: DIMENSIONS ARE IN MM [INCHES]		DRAWN	DATE	NAME		
			07/01/2011	LH		
TOLERANCES: ANGULAR: ± 3° DECIMALS X.= ± 0.38 [.015] X.= ± 0.25 [.010] .XX= ± 0.13 [.005]		THE INFORMATION HEREIN CONTAINS PROPRIETARY INFORMATION OF SULLINS ELECTRONICS AND IS NOT TO BE REPRODUCED, USED OR DISCLOSED TO OTHERS FOR ANY PURPOSE EXCEPT AS SPECIFICALLY AUTHORIZED IN WRITING BY AN OFFICER OF SULLINS ELECTRONICS.			TITLE 155 SERIES D-SUB HIGH PROFILE STRAIGHT TYPE	
		PART NUMBER SDS155-PR__ - __ - QN__ - 1			SIZE	CAGE CODE
		SCALE: 1:8		C	54453	11801
				C	SHEET 3 OF 3	