

PIN ASSIGNMENT

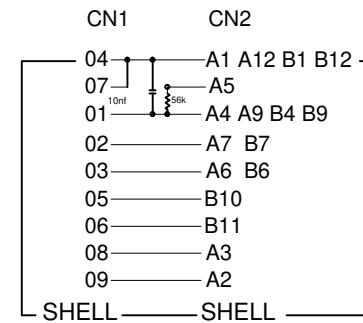

NOTES:

1. PIN ASSIGNMENT SEE TO WIRE LIST.
2. ELECTRICAL TEST CONDITION:
 - (a). 100% OPEN, SHORT & MISWIRE TEST,
 - (b). INSULATOR RESISTANCE: 10 Mohm MIN.
DC 300V 0.01sec.
 - (c). CONTACT RESISTANCE: 3ohm MAX.

5	SHELL.	
4	INNER MOLDED: PVC 45P.	
3	PCB: T=0.8mm with RESISTANCE: 56K ohm AND CAPACITANCE: 10NF.	
2	USB3.1C TYPE F WITH NICKLE PLATED SHELL G/F.	
1	USB3.0 A M BLUE PBT WITH NICKLE PLATED SHELL G/F.	
NO.	Description	P/N

DWG NO:	PCM-0154	GOODS CODE		Draw	Jason	Date	2019/3/13
ITEM NO.		DRAWING EVIDENCE		Check		Date	
Goods NO.				Approval		Date	
Original NO.		Unit(mm)					

PREMIER CABLE MFG CO LTD

D		
C		
B		
VER.A	REVISE	Date.