

PART NUMBER	REVISION	DESCRIPTION	FEED TYPE
2151710-1	C	FINE CRIMP HEIGHT ADJUST	MECHANICAL
2151710-2	C	FINE CRIMP HEIGHT ADJUST	PNEUMATIC
7-2151710-1	C	MECHANICAL AND CRIMP TOOLING KIT	MECHANICAL
7-2151710-2	C	PNEUMATIC AND CRIMP TOOLING KIT	PNEUMATIC
7-2151710-7	A	CRIMP TOOLING KIT	-

ATLANTIC VERSION TERMINATOR INTERFACE ADAPTER

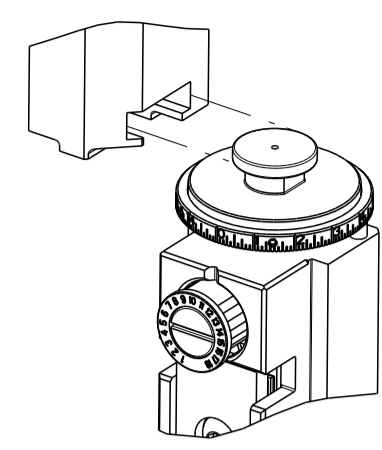

APPLICATOR DATA		
CRIMP	SIZE	TYPE
WIRE	2.58 mm [.102]	F
INSUL	3.57 mm [.141]	F

APPLICATOR INSTRUCTIONS
408-35042

TERMINAL DATA: TE TERMINAL		TE CRIMP SPECIFICATION	
TERMINAL NAME: MALE BULLET TERMINAL			
WIRE STRIP LENGTH		INSULATION DIAMETER RANGE	
3.18-4.06 mm [.125-.160 IN]		Ø0.00-2.54 mm [.000-.100 IN]	
TERMINAL APPLICATION SPECIFICATION	NONE		
TERMINALS APPLIED			
TE TERMINAL	FCI	TE TERMINAL	TE TERMINAL
2113284-1	RB-1618-2		

WIRE SIZE	CRIMP HEIGHT mm [INCH]	CRIMP HEIGHT REFERENCE SETTING
16 AWG	1.78+/-0.05 [.070+/- .002]	7.9
18 AWG	1.65+/-0.05 [.065+/- .002]	9.2

- 1. RECOMMENDED SPARE PARTS
- 2. REFER TO SUPPLIED INSTRUCTION SHEET FOR CLEANING, LUBRICATION AND STORAGE OF APPLICATOR.
- 3. APPLY PART NUMBER 2-23419-6 LOCTITE TO THREADS OF ITEM 242.
- 4. CRIMP HEIGHT REFERENCE SETTING WAS THE SETTING USED WHEN THE APPLICATOR WAS QUALIFIED AT THE FACTORY. ADJUSTMENT MAY BE NECESSARY WHEN RUNNING APPLICATOR IN THE FIELD.
- 5. UNLESS SPECIFIED OTHERWISE TORQUE VALUES SHALL BE USED PER DOCUMENT, 101-35000.
- 6. CUT TO LENGTH AT ASSEMBLY.
- 7. GUIDE FEED PAW OUT OF SLOT.

***WARNING**
ON INSTALLATION, SET WIRE DISC TO CRIMP HEIGHT REFERENCE SETTING FOR LARGEST WIRE SIZE. CRIMP HEIGHT REFERENCE SETTINGS GREATER THAN THE VALUE SHOWN MAY CAUSE DAMAGE TO THE CRIMP TOOLING, REFER TO THE INSTRUCTION SHEET FOR PROPER SETUP AND ADJUSTMENTS.

ATLANTIC VERSION
Shown on sheets 1 of 4 & 2 of 4
(Pacific version shown on sheets 3 of 4 & 4 of 4)

LOC	DIST	REVISIONS					
A	66	P	LTN	DESCRIPTION	DATE	OWN	APVD
		A		RELEASED	03OCT2012	BH	BH
		B		ECR-22-150572	26AUG2022	FZ	TE
		C		ECR-22-156008	19OCT2022	FZ	JAH

1	-	1	1	1	1	2280441-1	INSERT, SHEAR	282
	-	1	-	1	-	2119641-1	FEED CAM, AIR FEED	248
	-	1	1	1	1	2119082-9	CAM, SNAIL, INSULATION ADJUSTMENT	244
	-	1	1	1	1	2079764-1	WASHER, WAVE SPRING, CREST-TO-CREST	243
3	-	1	1	1	1	2119083-1	RETAINER, INSULATION DIAL	242
	-	2	2	2	2	7-18023-7	SCR, SKT HD CAP M3 X 4.0	241
	-	-	1	-	1	2119580-1	MECHANICAL FEED ASSEMBLY	239
	-	1	-	1	-	2844940-1	AIR FEED MODULE	238
	-	1	1	1	1	356885-4	STOP, SHEAR	237
	-	REF	REF	REF	REF	994970-2	COUNTER, MAGNETIC	164
	-	1	1	1	1	1-18028-2	WASHER, FLAT, REG M4	119
	-	1	1	1	1	2844908-1	SCREW, LOCKING	99
	-	1	1	1	1	2844907-1	POST, LOCKING	98
	-	1	1	1	1	455888-4	SPACER, CRIMPER	82
	-	1	1	1	1	7-240641-3	SPACER	81
	-	1	1	1	1	22278-8	SPRING, COMPRESSION	77
	-	1	1	1	1	854769-4	HOLDER, INS	74
	-	1	1	1	1	1803607-3	DOCUMENTATION PACKAGE	71
	-	1	1	1	1	2119740-1	TAG, IDENTIFICATION	67
	-	2	2	2	2	2168078-1	SCREW, DRIVE, RH, RoHS, 2 x .188	66
	-	1	1	1	1	2168083-2	SCR, SKT HD CAP, RoHS, M4 X 8.0	60
	-	1	1	1	1	5-18022-5	SCR, HEX HD CAP, M4 X 6.0	59
	-	1	1	1	1	21028-2	PIN, SLOTTED SPRING .062 X .250	58
	-	1	1	1	1	1338685-1	PAWL, FEED	56
	-	4	4	4	4	2168083-3	SCR, SKT HD CAP, RoHS, M4 X 12.0	54
6	-	2	2	2	2	1-2168083-2	SCR, SKT HD CAP, RoHS, M4 X 25	53
	-	1	2	1	2	18023-9	SCR, SKT HD CAP M4 X 6.0	49
	-	-	1	-	1	2119652-1	FEED CAM, PRE FEED	48
	-	-	1	-	1	2119653-1	FEED CAM, POST FEED	47
	-	1	1	1	1	1803583-9	APPLICATOR BASIC ASSEMBLY, SF	46
	-	1	1	1	1	1803515-1	RAM ASSEMBLY, SF ATLANTIC	44
	-	1	1	1	1	1803602-1	SCR, BHSC, RoHS (M8 X 25)	41
	-	2	2	2	2	2079383-5	SCR, BHSC, RoHS (M4 X 20)	33
	-	2	2	2	2	3-2844962-0	SPACER, CYLINDRICAL, STRIP GUIDE	30
	-	1	1	1	1	2844992-1	ASSEMBLY, STRIP GUIDE	29
	-	1	1	1	1	1-455888-0	SPACER, CRIMPER	28
	-	1	1	1	1	1320928-6	STRIP GUIDE	24
	-	1	1	1	1	2168083-2	SCR, SKT HD CAP, RoHS, M4 X 8.0	21
	-	1	1	1	1	1-18028-2	WASHER, FLAT, REG M4	20
	-	1	1	1	1	2119533-1	STRIPPER, SIDE FEED	19
	-	1	1	1	1	690463-1	FLOATING SHEAR, REAR	17
	-	2	2	2	2	1-2168083-1	SCR, SKT HD CAP, RoHS, M3 X 6	16
	-	1	1	1	1	1-690464-3	SHEAR PLATE, REAR	15
	-	1	1	1	1	2119862-1	SHEAR HOLDER, REAR	14
1	-	1	1	1	1	2119806-1	INSERT, SHEAR	13
	-	2	2	2	2	3-22280-3	SPRING, COMPRESSION	12
	-	1	1	1	1	1-356885-3	STOP, SHEAR	11
1	-	1	1	1	1	2119805-1	SHEAR HOLDER, FRONT	10
1	-	1	1	1	1	454276-5	FLOATING SHEAR, FRONT	9
1	1	2	2	1	1	1803058-1	ANVIL, COMBINATION	8
	-	-	-	-	-	-	-	7
	-	1	1	1	1	690468-6	DEPRESSOR SHEAR, REAR	6
	-	1	1	1	1	2119780-9	DEPRESSOR, SHEAR	5
	-	1	1	1	1	238011-8	BLOCK, CRIMPER SPACER	4
1	1	2	2	1	1	2-2119582-4	CRIMPER, INSULATION F PREMIUM	3
	-	1	1	1	1	1-455888-1	SPACER, CRIMPER	2
1	1	2	2	1	1	3-1633305-3	CRIMPER, WIRE PREMIUM	1

DIMENSIONS:		TOLERANCES UNLESS OTHERWISE SPECIFIED:		MATERIAL:		FINISH:	
mm	0 PLC ±	1 PLC ±	2 PLC ±	3 PLC ±	4 PLC ±	ANGLES	FINISH

DATE	24 JULY 2012	CHKD	HOFFNER
DATE	25 JULY 2012	CHKD	G. BAILEY
DATE	25 JULY 2012	APVD	G. BAILEY
PRODUCT SPEC		APPLICATION SPEC	
SIZE	A1	CAGE CODE	00779
DRAWING NO	2151710	SCALE	1:2
SHEET	1	OF	4
REV	C		

LOC		DIST		REVISIONS			
NO.	REV.	BY	DATE	DESCRIPTION	DATE	BY	APPV
A	66			SEE SHEET 1			

FEED TYPE MECHANICAL

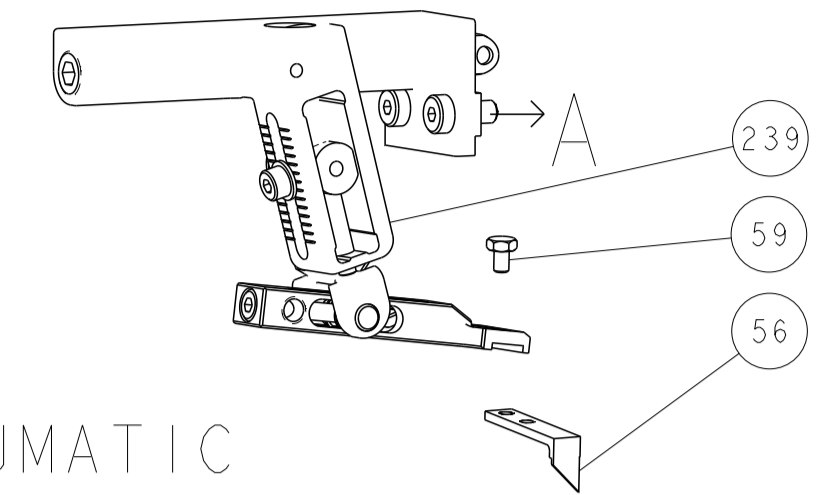

PNEUMATIC

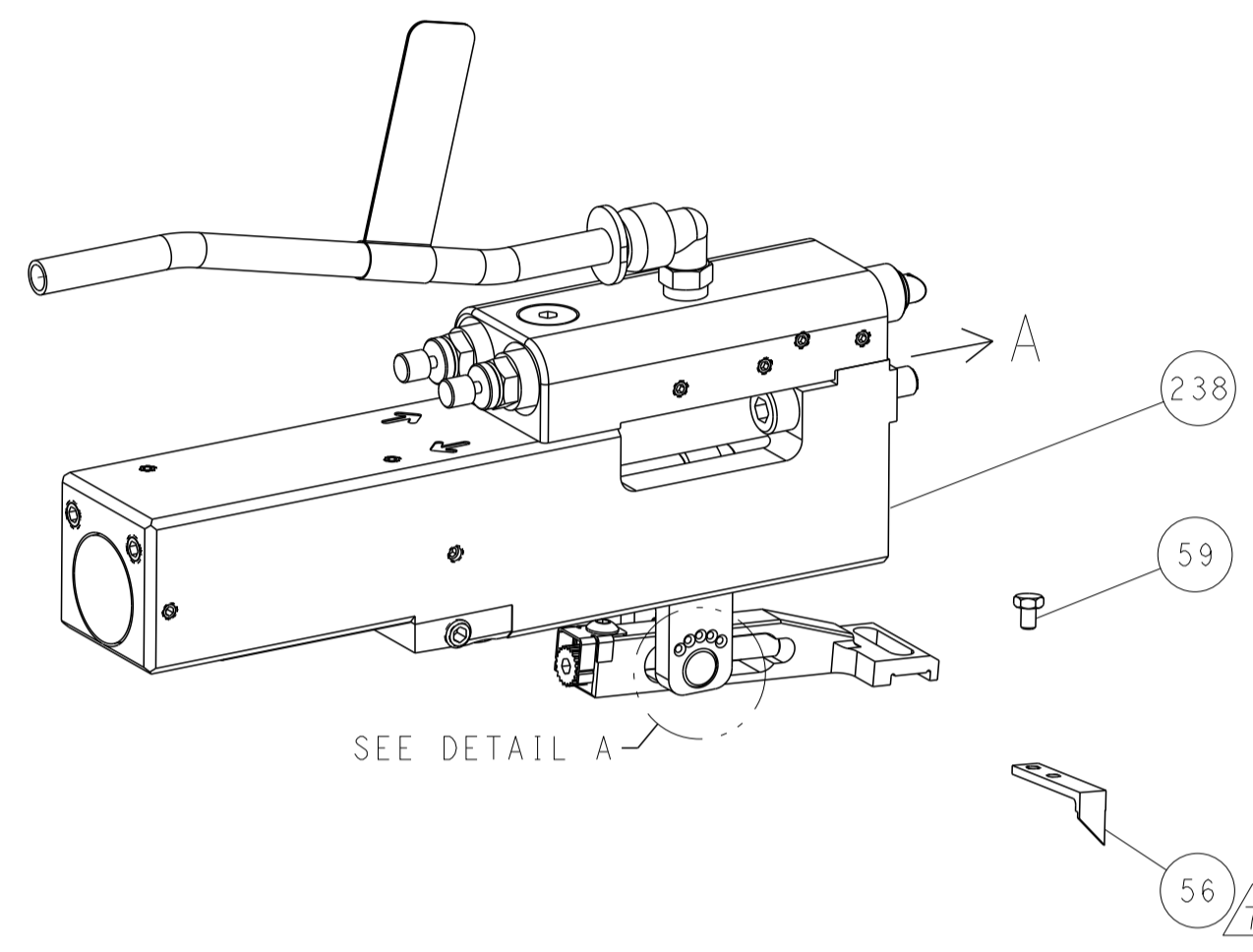

FEED SPRING SETTING POSITION (SHOWN FROM REAR SIDE)

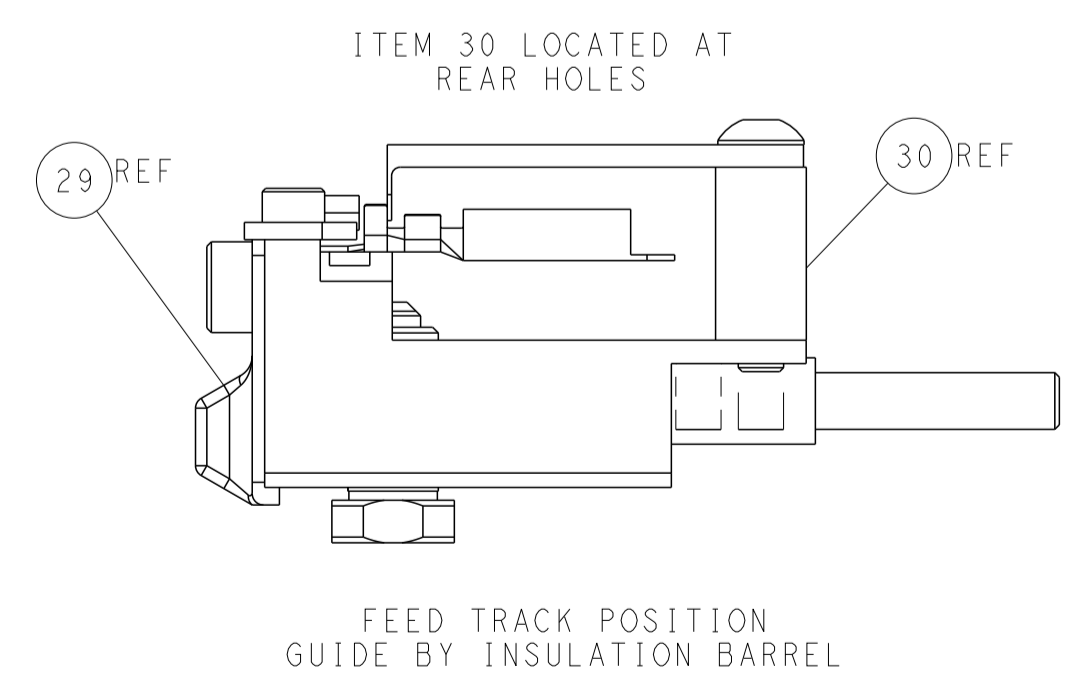
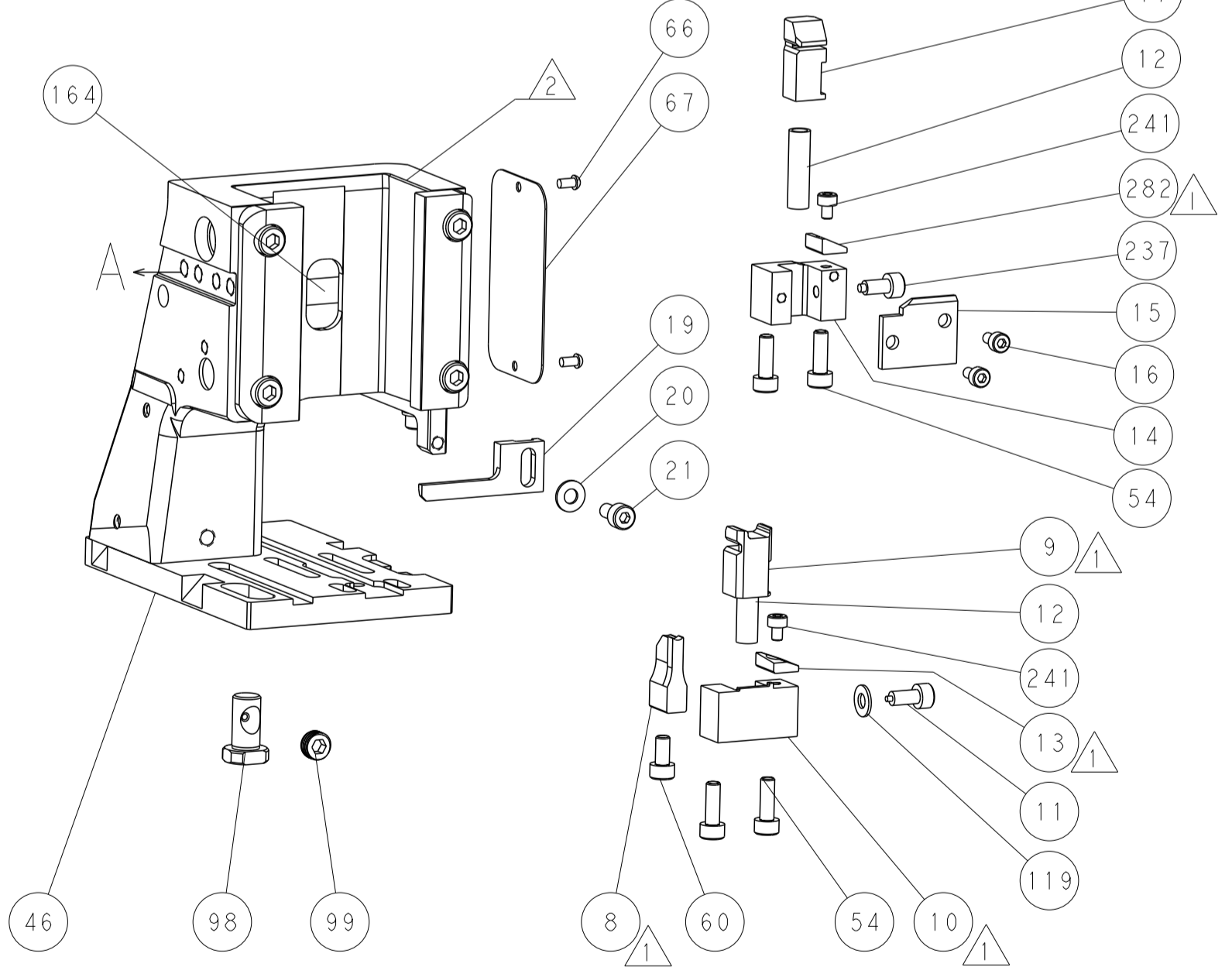
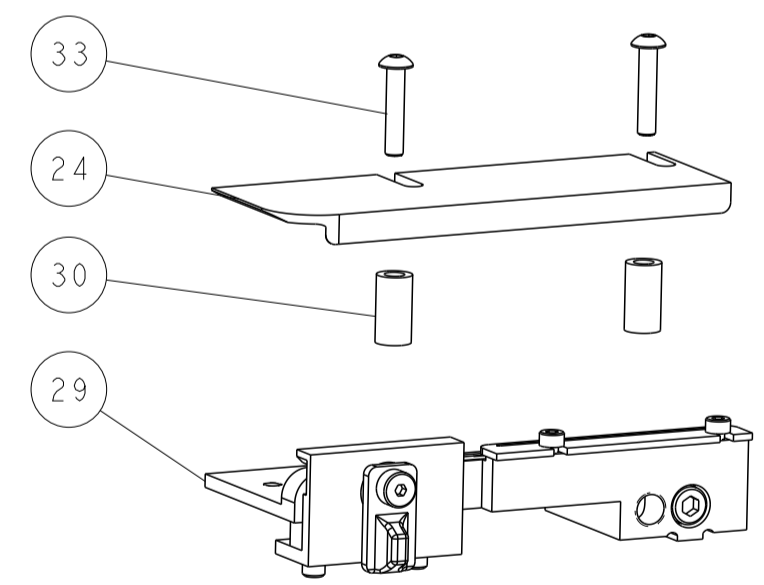
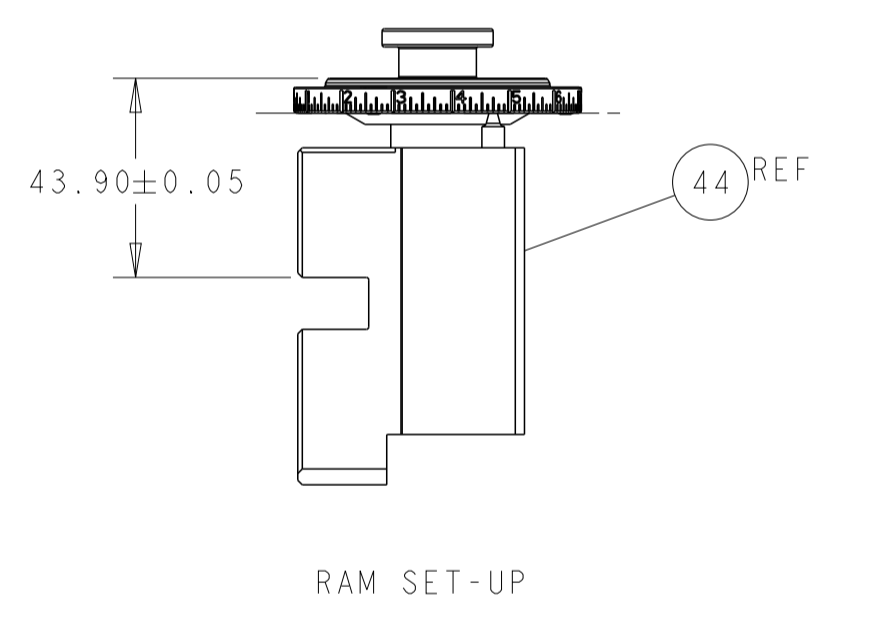
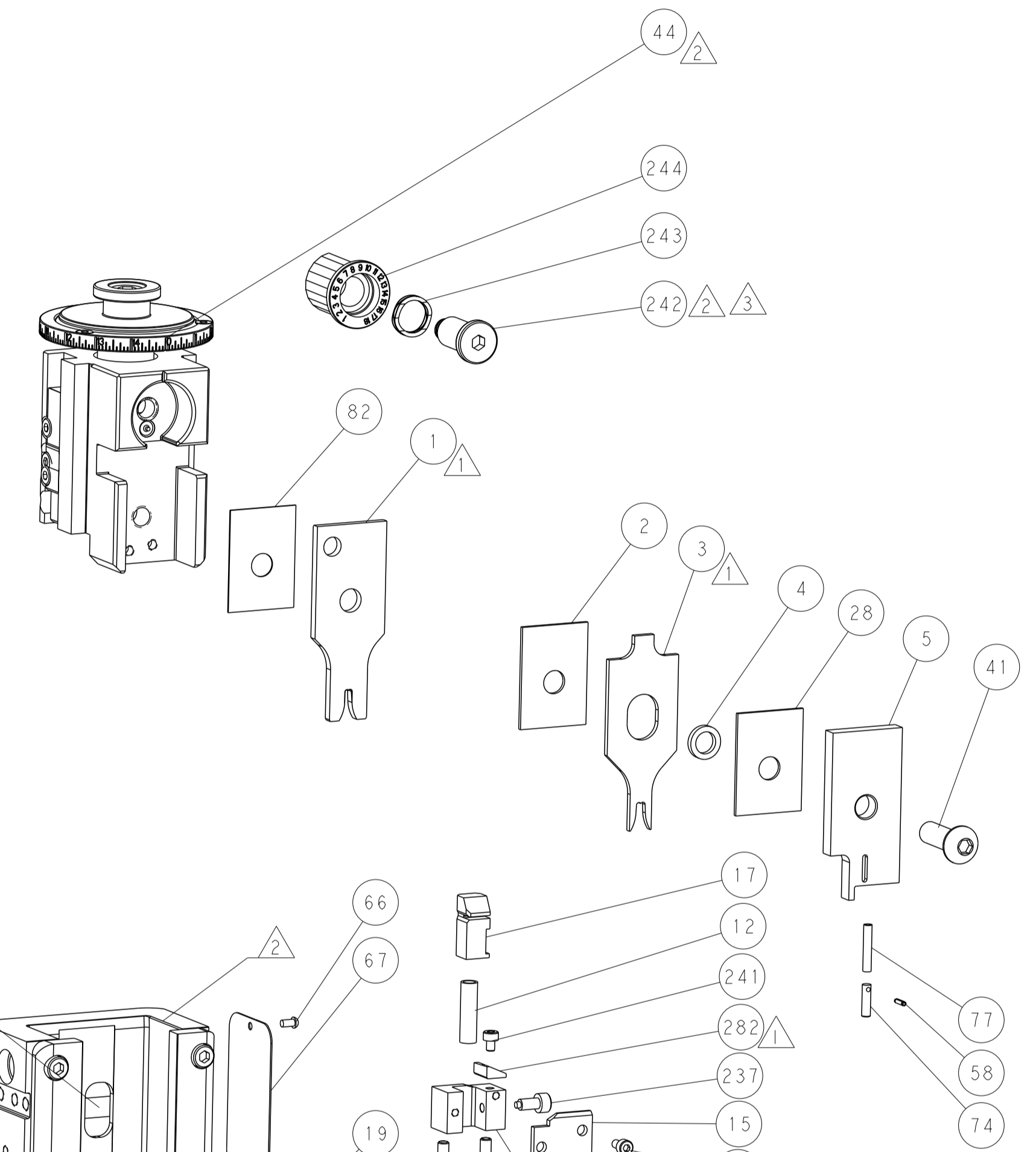
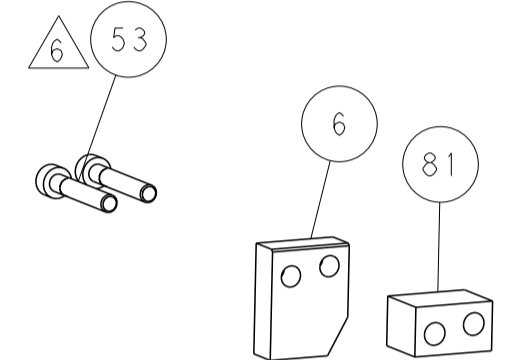
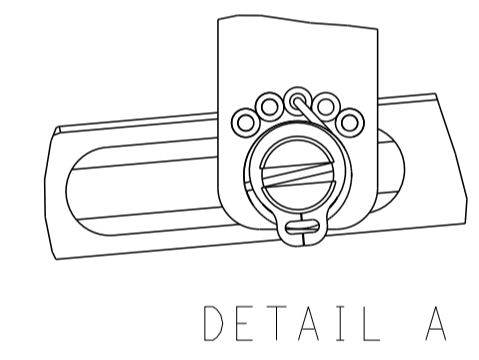

CAM POSITIONS

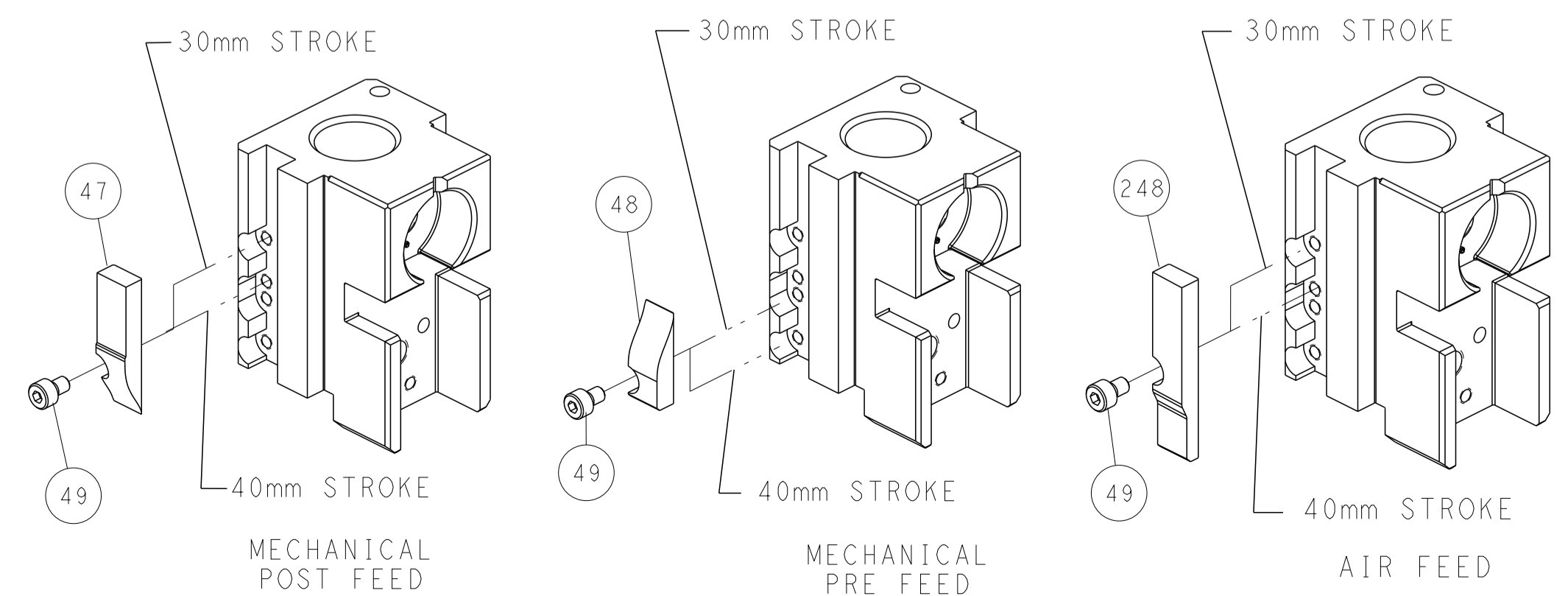

ATLANTIC VERSION
 Shown on sheets 1 of 4 & 2 of 4
 (Pacific version shown on sheets 3 of 4 & 4 of 4)

DIMENSIONS:		TOLERANCES UNLESS OTHERWISE SPECIFIED:		DWG: HOFFNER 24JULY2012		TE Connectivity	
mm	0 PLC ±	1 PLC ±	2 PLC ±	3 PLC ±	4 PLC ±	NAME: G. BAILEY 25JULY2012	Harrisburg, PA 17105-3608
MATERIAL:		FINISH:		APVD: G. BAILEY 25JULY2012		Customer Accessible Production Drawing	
				WEIGHT:		SCALE: 1:2	
				SIZE: A1		SHEET 2 OF 4	
				CAGE CODE: 00779		REV C	
				DRAWING NO: 2151710		SHEETS 3 & 4 ARE NOT REQUIRED FOR ATLANTIC VERSION	

PART NUMBER	REVISION	DESCRIPTION	FEED TYPE
2-2151710-1	C	FINE CRIMP HEIGHT ADJUST	MECHANICAL
2-2151710-2	C	FINE CRIMP HEIGHT ADJUST	PNEUMATIC
7-2151710-7	A	CRIMP TOOLING KIT	-

PACIFIC VERSION TERMINATOR
 INTERFACE ADAPTER



APPLICATOR DATA		
CRIMP	SIZE	TYPE
WIRE	2.58 mm [.102]	F
INSUL	3.57 mm [.141]	F
APPLICATOR INSTRUCTIONS 408-35042		

TERMINAL DATA: TE TERMINAL		TE CRIMP SPECIFICATION	
TERMINAL NAME: MALE BULLET TERMINAL			
WIRE STRIP LENGTH		INSULATION DIAMETER RANGE	
3.18-4.06 mm [.125-.160 IN]		Ø0.00-2.54 mm [.000-.100 IN]	
TERMINAL APPLICATION SPECIFICATION	NONE		
TERMINALS APPLIED			
TE TERMINAL	FCI	TE TERMINAL	TE TERMINAL
2113284-1	RB-1618-2		

WIRE SIZE	CRIMP HEIGHT mm [INCH]	CRIMP HEIGHT REFERENCE SETTING
16 AWG	1.78+/-0.05 [.070+/-0.002]	7.9
18 AWG	1.65+/-0.05 [.065+/-0.002]	9.2



- 1 RECOMMENDED SPARE PARTS
- 2 REFER TO SUPPLIED INSTRUCTION SHEET FOR CLEANING, LUBRICATION AND STORAGE OF APPLICATOR.
- 3 APPLY PART NUMBER 2-23419-6 LOCTITE TO THREADS OF ITEM 242.
- 4 CRIMP HEIGHT REFERENCE SETTING WAS THE SETTING USED WHEN THE APPLICATOR WAS QUALIFIED AT THE FACTORY. ADJUSTMENT MAY BE NECESSARY WHEN RUNNING APPLICATOR IN THE FIELD.
- 5. UNLESS SPECIFIED OTHERWISE TORQUE VALUES SHALL BE USED PER DOCUMENT, 101-35000.
- 6 CUT TO LENGTH AT ASSEMBLY.
- 7 GUIDE FEED PAW OUT OF SLOT.

***WARNING**
 ON INSTALLATION, SET WIRE DISC TO CRIMP HEIGHT REFERENCE SETTING FOR LARGEST WIRE SIZE. CRIMP HEIGHT REFERENCE SETTINGS GREATER THAN THE VALUE SHOWN MAY CAUSE DAMAGE TO THE CRIMP TOOLING, REFER TO THE INSTRUCTION SHEET FOR PROPER SETUP AND ADJUSTMENTS.

PACIFIC VERSION
 Shown on sheets 3 of 4 & 4 of 4
 (Atlantic version shown on sheets 1 of 4 & 2 of 4)

LOC	DIST	REVISIONS					
A	66	P	LTN	DESCRIPTION	DATE	OWN	APVD
-	-	-	-	SEE SHEET 1	-	-	-

△	-	1	1	2280441-1	INSERT, SHEAR		282
-	-	1	1	2119082-9	CAM, SNAIL, INSULATION ADJUSTMENT		244
-	-	1	1	2079764-1	WASHER, WAVE SPRING, CREST-TO-CREST		243
△	-	1	1	2119083-1	RETAINER, INSULATION DIAL		242
-	-	2	2	7-18023-7	SCR, SKT HD CAP M3 X 4.0		241
-	-	-	1	2119580-1	MECHANICAL FEED ASSEMBLY		239
-	-	1	-	2844940-1	AIR FEED MODULE		238
-	-	1	1	356885-4	STOP, SHEAR		237
-	REF	REF		994970-2	COUNTER, MAGNETIC		164
-	-	1	-	2119641-2	FEED CAM, AIR FEED		151
-	-	1	1	2168083-8	SCR, SKT HD CAP, RoHS, M4 X 16		144
-	-	4	4	2168083-9	SCR, SKT HD CAP, RoHS, M4 X 20		143
-	-	-	1	2119653-2	FEED CAM, POST FEED		142
-	-	1	1	1-1803583-0	APPLICATOR BASIC ASSEMBLY, SF		141
-	-	1	1	1803516-1	RAM ASSEMBLY, SF PACIFIC		140
-	-	1	1	1-18028-2	WASHER, FLAT, REG M4		119
-	-	1	1	2844908-1	SCREW, LOCKING		99
-	-	1	1	2844907-1	POST, LOCKING		98
-	-	1	1	455888-4	SPACER, CRIMPER		82
-	-	1	1	7-240641-3	SPACER		81
-	-	1	1	22278-8	SPRING, COMPRESSION		77
-	-	1	1	854769-4	HOLDER, INS		74
-	-	1	1	1803607-3	DOCUMENTATION PACKAGE		71
-	-	1	1	2119740-1	TAG, IDENTIFICATION		67
-	-	2	2	2168078-1	SCREW, DRIVE, RH, RoHS, 2 x .188		66
-	-	1	1	5-18022-5	SCR, HEX HD CAP, M4 X 6.0		59
-	-	1	1	21028-2	PIN, SLOTTED SPRING .062 X .250		58
-	-	1	1	1338685-1	PAWL, FEED		56
△	-	2	2	1-2168083-2	SCR, SKT HD CAP, RoHS, M4 X 25		53
-	-	1	2	18023-9	SCR, SKT HD CAP M4 X 6.0		49
-	-	-	1	2119652-1	FEED CAM, PRE FEED		48
-	-	1	1	1803602-1	SCR, BHSC, RoHS (M8 X 25)		41
-	-	2	2	2079383-5	SCR, BHSC, RoHS (M4 X 20)		33
-	-	2	2	3-2844962-0	SPACER, CYLINDRICAL, STRIP GUIDE		30
-	-	1	1	2844992-1	ASSEMBLY, STRIP GUIDE		29
-	-	1	1	1-455888-0	SPACER, CRIMPER		28
-	-	1	1	1320928-6	STRIP GUIDE		24
-	-	1	1	2168083-2	SCR, SKT HD CAP, RoHS, M4 X 8.0		21
-	-	1	1	1-18028-2	WASHER, FLAT, REG M4		20
-	-	1	1	2119533-1	STRIPPER, SIDE FEED		19
-	-	1	1	690463-1	FLOATING SHEAR, REAR		17
-	-	2	2	1-2168083-1	SCR, SKT HD CAP, RoHS, M3 X 6		16
-	-	1	1	1-690464-3	SHEAR PLATE, REAR		15
-	-	1	1	2119862-1	SHEAR HOLDER, REAR		14
△	-	1	1	2119806-1	INSERT, SHEAR		13
-	-	2	2	3-22280-3	SPRING, COMPRESSION		12
-	-	1	1	1-356885-3	STOP, SHEAR		11
△	-	1	1	2119805-1	SHEAR HOLDER, FRONT		10
△	-	1	1	454276-5	FLOATING SHEAR, FRONT		9
△	1	1	1	1803058-1	ANVIL, COMBINATION		8
-	-	-	-	-	-		7
-	-	1	1	690468-6	DEPRESSOR SHEAR, REAR		6
-	-	1	1	2119780-9	DEPRESSOR, SHEAR		5
-	-	1	1	238011-8	BLOCK, CRIMPER SPACER		4
△	1	1	1	2-2119582-4	CRIMPER, INSULATION F PREMIUM		3
-	-	1	1	1-455888-1	SPACER, CRIMPER		2
△	1	1	1	3-1633305-3	CRIMPER, WIRE PREMIUM		1

DIMENSIONS:		TOLERANCES UNLESS OTHERWISE SPECIFIED:		MATERIAL:		FINISH:	
mm	0 PLC ±	1 PLC ±	2 PLC ±	3 PLC ±	4 PLC ±	ANGLES ±	FINISH ±
MATERIAL:		FINISH:		WEIGHT:		SCALE:	
-		-		-		1:2	

ITEM NO	PART NO	DESCRIPTION	ITEM NO
-77	-22	-21	

OWN: HOFFNER 24JULY2012	TE Connectivity
CHK: G. BAILEY 25JULY2012	Harrisburg, PA 17105-3608
APVD: G. BAILEY 25JULY2012	
NAME: Ocean Side Feed Applicator	
SIZE: A1	CAGE CODE: 00779
DRAWING NO: C=2151710	
Customer Accessible Production Drawing	
SHEET 3 OF 4	

LOC		DIST		REVISIONS			
A	66	P	LTM	DESCRIPTION	DATE	OWN	APVD
		-	-	SEE SHEET 1	-	-	-

FEED TYPE MECHANICAL

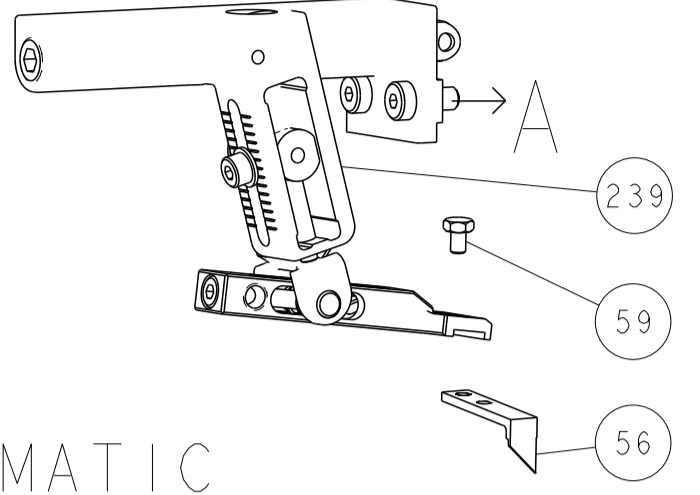

PNEUMATIC

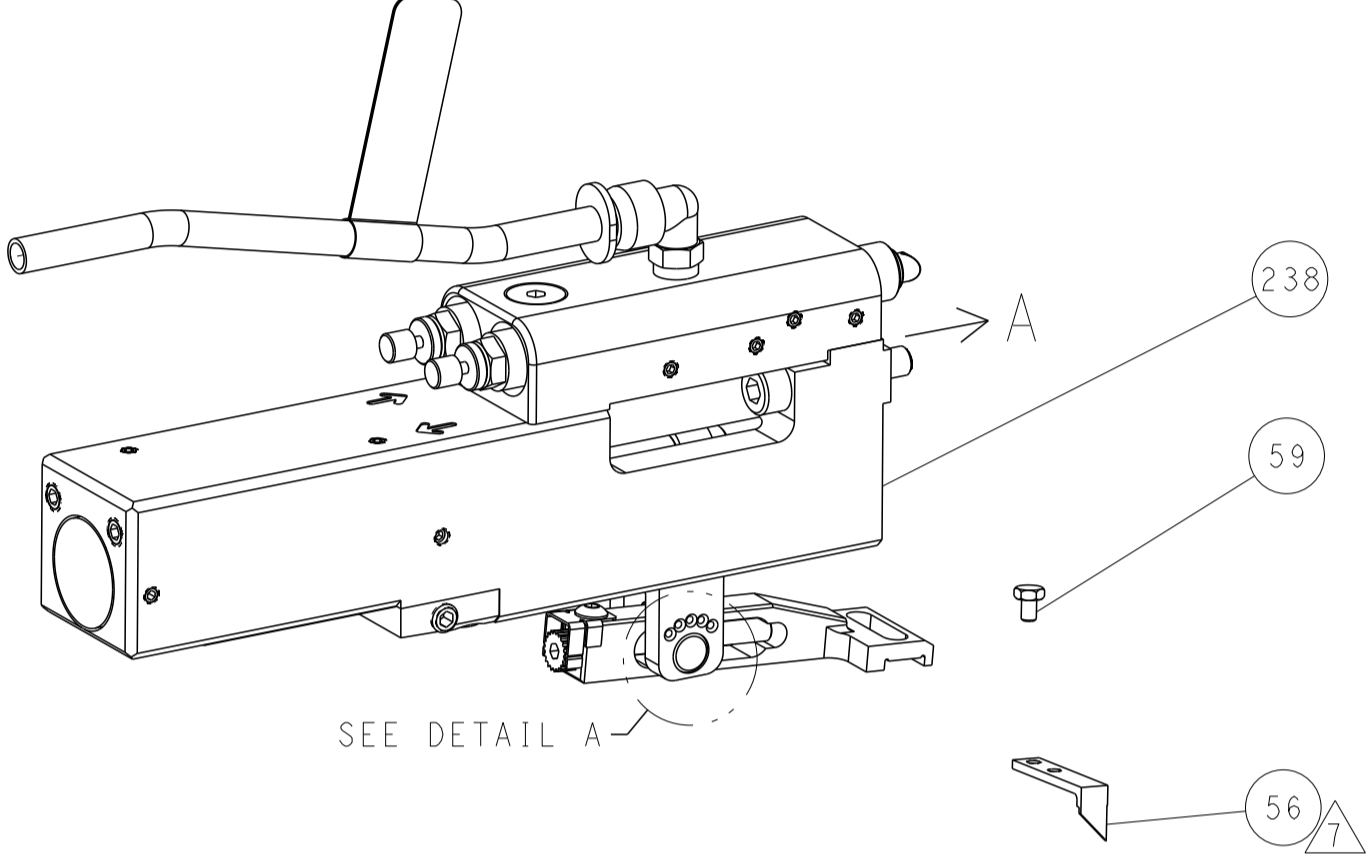

FEED SPRING SETTING POSITION
(SHOWN FROM REAR SIDE)

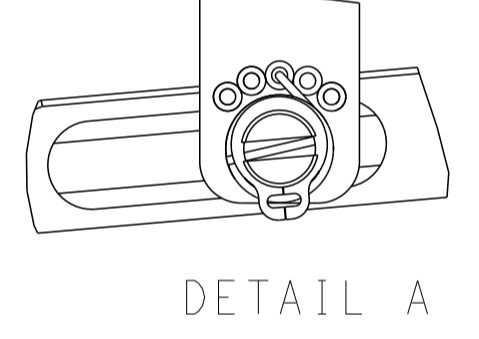

DETAIL A

CAM POSITIONS

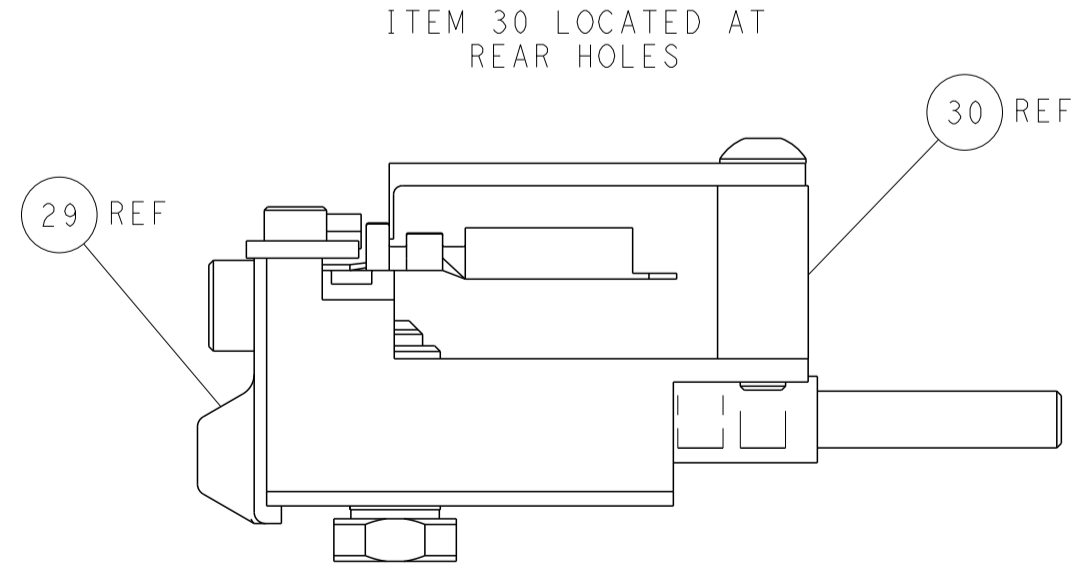
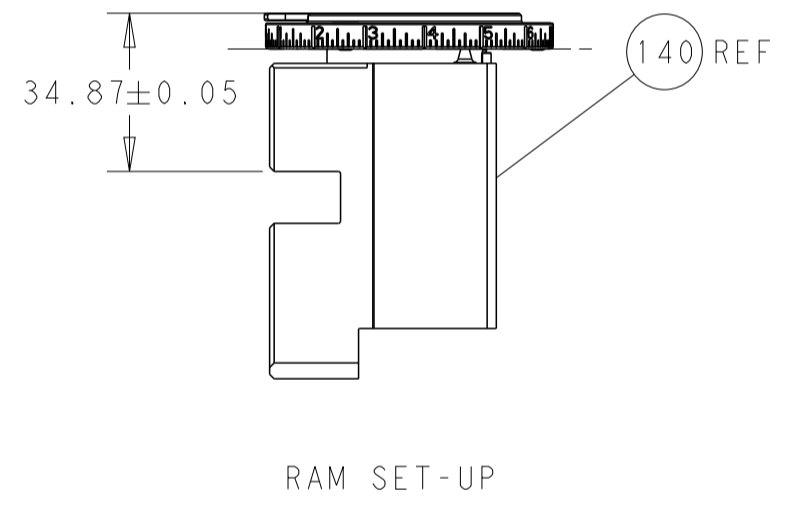
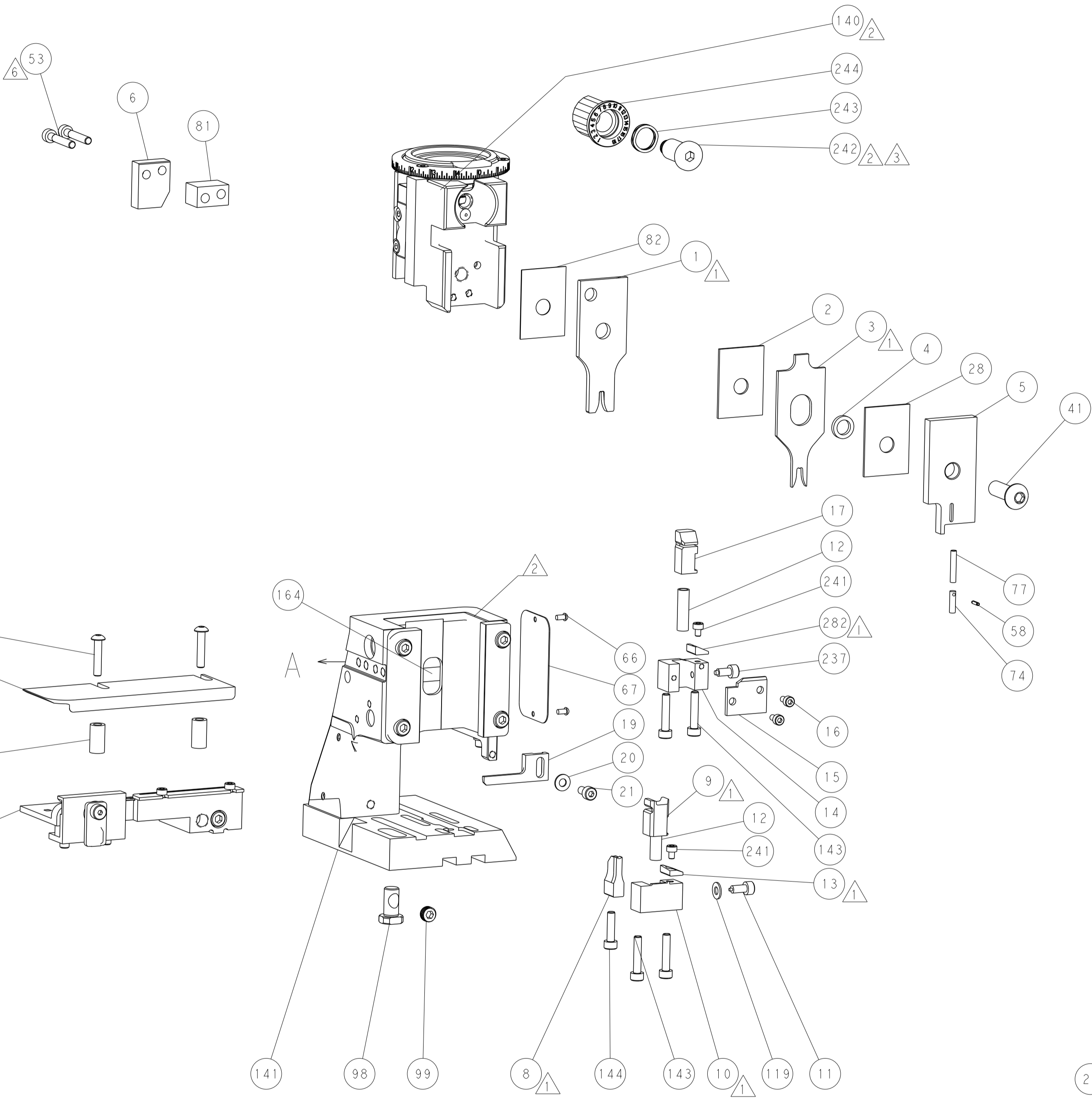
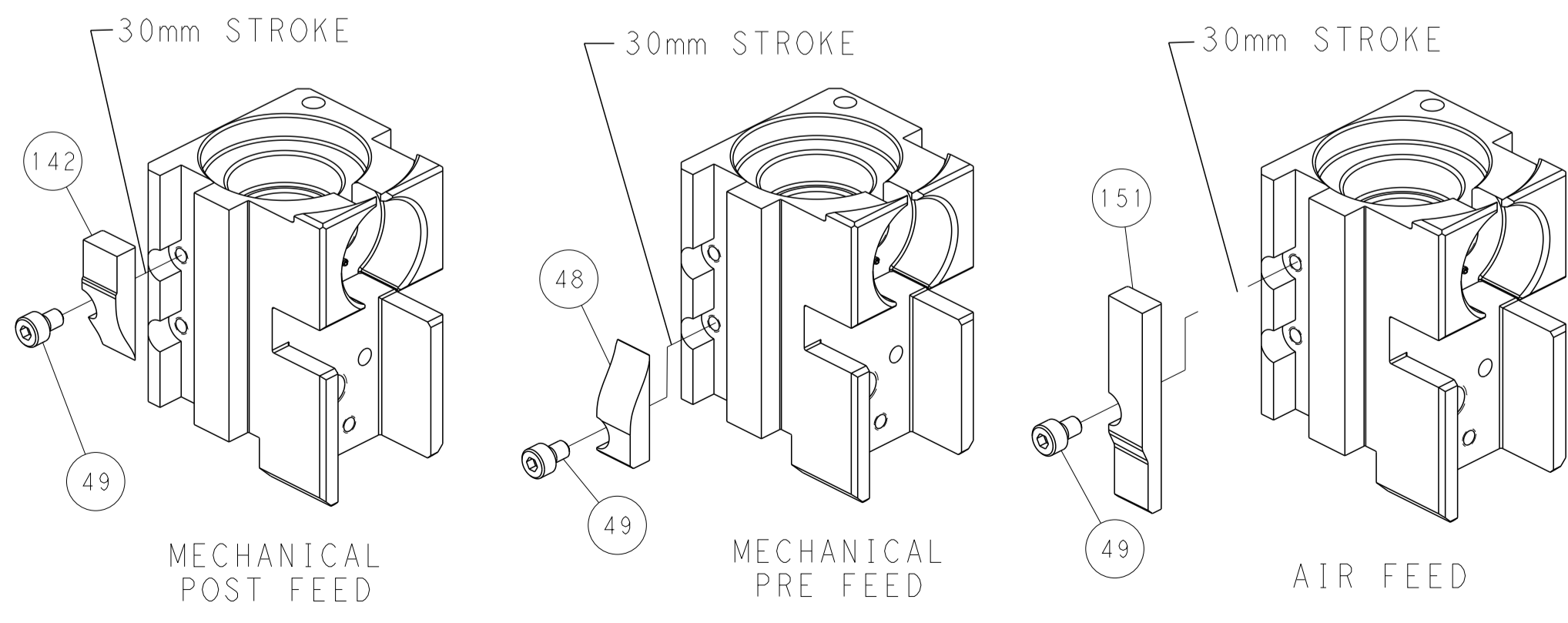

PACIFIC VERSION
 Shown on sheets 3 of 4 & 4 of 4
 (Atlantic version shown on sheets 1 of 4 & 2 of 4)

DIMENSIONS:		TOLERANCES UNLESS OTHERWISE SPECIFIED:		DWN: HOFFNER 24JULY2012		TE Connectivity	
mm	0 PLC ±	1 PLC ±	2 PLC ±	3 PLC ±	4 PLC ±	Harrisburg, PA 17105-3608	
MATERIAL:		FINISH:		APVD: G. BAILEY 25JULY2012		NAME: Ocean Side Feed Applicator	
				CAGE CODE: A1100779		DRAWING NO: C-2151710	
				WEIGHT:		SCALE: 1:2	
				SHEET: 4 OF 4		REV: C	