

PART NAME: KNOB      SCALE: 1:1      DATE: 8/28/72      DR. BY NH

THIS DRAWING IS THE PROPERTY OF DAVIES MOLDING COMPANY, IS SUBMITTED SOLELY AS A DESIGN OR ENGINEERING PROJECT. WE ACCEPT NO RESPONSIBILITY WHATSOEVER FOR THE PRACTICAL APPLICATION OF THE PIECES MADE TO THIS DESIGN.



P/N 3030-T	
M NO. 3000	
CAVITY	3000
PLUNGER	3030
SHIMS	1/4
PIN	3000-D
INSERT	10035

CAD/REDRAWN : 6/28/94 : HD

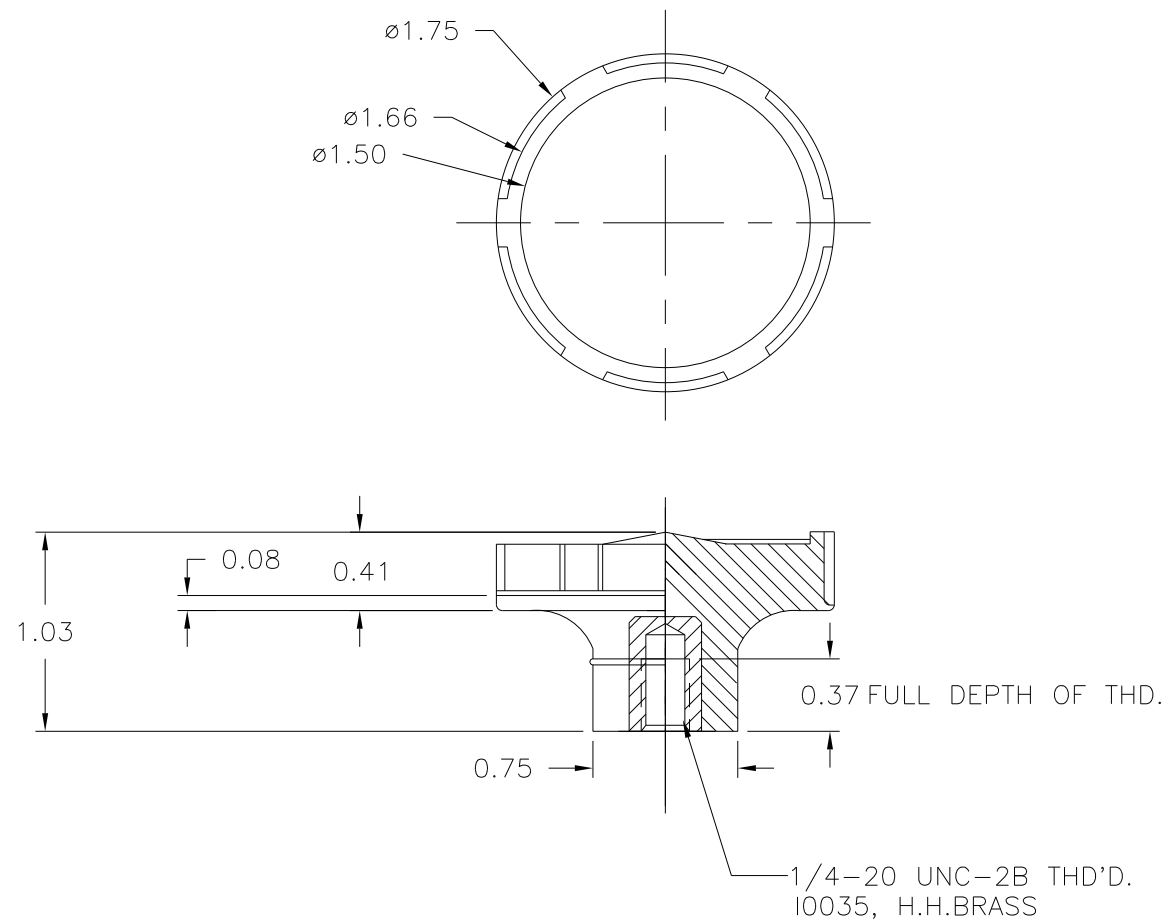

MATERIAL: #4311 PLENCO PHENOLIC (B41)  
 COLOR: BLACK

TOLERANCES: UNLESS OTHERWISE SPECIFIED	DO NOT SCALE DRAWING				
DECIMALS: X.XXX ± .005 X.XX ± .015	MM: X.XX ± 0.15MM X.X ± 0.4MM				
FRACTIONS ± 1/64	ANG. ± 1°	CHANGES			