

NEW

PTS815 Series Microminiature SMT Top Actuated

B
Tactile Switches

Features/Benefits

- 4.2 x 3.2 mm footprint
- 2.5 mm thickness
- Commercial grade

Typical Applications

- IoT devices
- Home Automation
- Remote Controls



Specifications

FUNCTION: momentary action
 CONTACT ARRANGEMENT: 1 make contact = SPST N.O.
 TERMINALS: J type for SMT
 TRAVEL: 0.20mm ± 0.1mm

	Operating Force (gf)	Operating Life (operations)
PTS815 SJM 250 SMTR LFS	180 ± 50	100,000
PTS815 SJK 250 SMTR LFS	250 ± 50	100,000
PTS815 SJG 250 SMTR LFS	400 ± 100	100,000

Electrical

MAXIMUM VOLTAGE: 12 VDC
 MAXIMUM CURRENT DC: 50 mA
 DIELECTRIC STRENGTH: 250 VA C (1mn)
 CONTACT RESISTANCE: ≤ 100 mΩ initial
 INSULATION RESISTANCE: ≥ 100 MΩ
 BOUNCE TIME: ≤ 10 ms

Environmental

OPERATING TEMPERATURE: -40°C to 90°C

Process

SOLDERING: This component is suited to the following methods:
 Infrared Reflow Soldering in accordance with IEC61760-1

NOTE:

- Specifications listed above are for switches with standard options. For information on specific and custom switches, consult Customer Service Center.
- The PTS series is not certified for using in Automotive application and no PPAP. However, in the case of some automotive accessories and specific applications for 2 and 3 wheeled vehicles the PTS is widely used and very suitable. Please contact your local C&K representative to discuss your application and the best switch solution.

Packaging

Switches in reels of 3,000 pieces.
 Dimensions of reels according to EIA 481B
 External diameter 330 mm

How To Order

Our easy build-a-switch concept allows you to mix and match options to create the switch you need. To order, select desired option from each category and place it in the appropriate box.

For any part number different from those listed above, please consult your local representative.

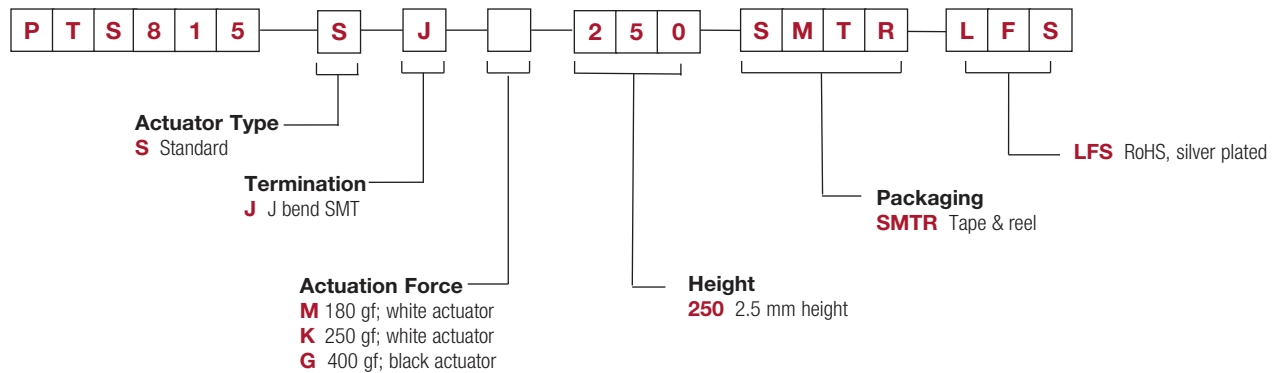

PTS815 Series Microminiature SMT Top Actuated

PTS815

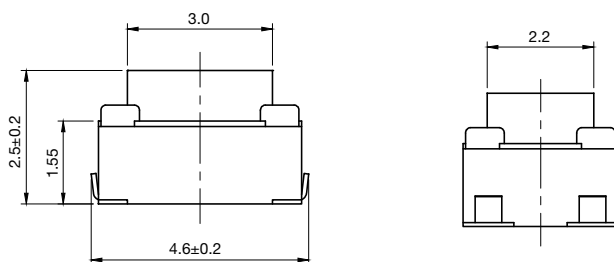
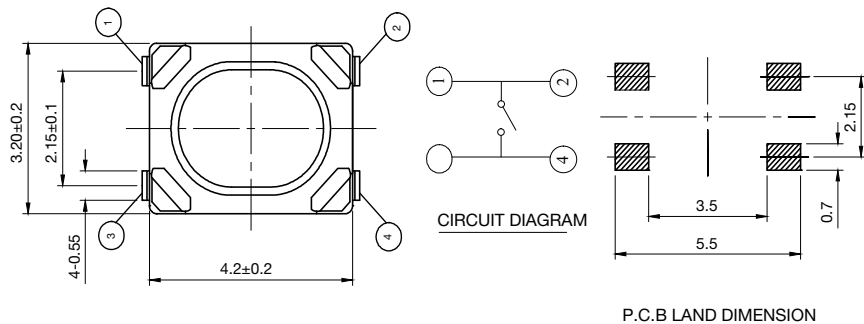

TAPE & REEL

