

**TD-24610-000**  
SHT 1.1

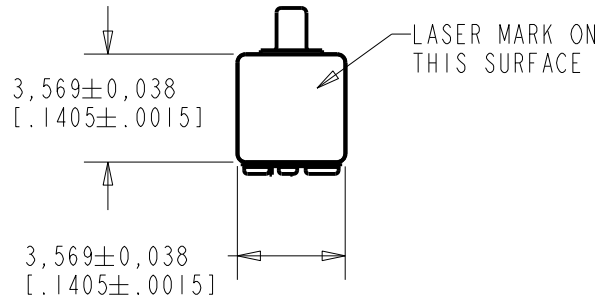

NOTES:

1. INCREASED PRESSURE AT THE SOUND INLET CAUSES A POSITIVE GOING VOLTAGE TO APPEAR AT THE OUTPUT TERMINAL, RELATIVE TO THE NEGATIVE TERMINAL.

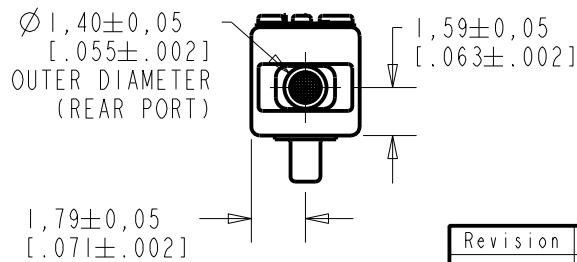
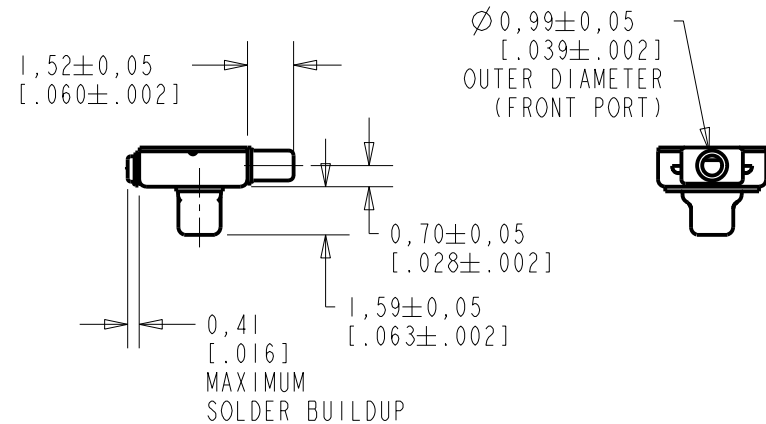
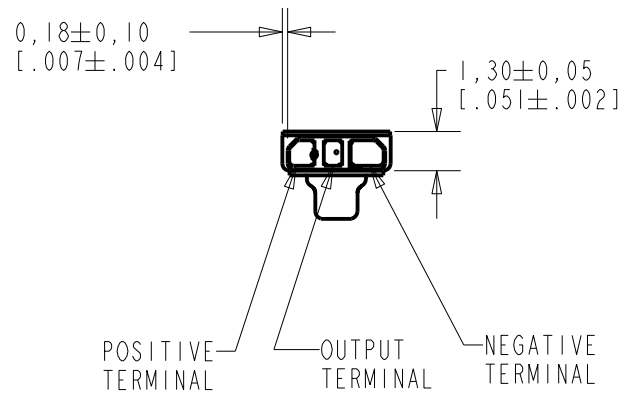

NOMINAL WEIGHT  
.063 GRAMS

DIMENSIONS IN MILLIMETERS [INCHES]

Revision	C.O. #	Implementation Date	RELEASE LEVEL	REVISION
H	MI0105050	5-20-13	Active	H
G	MI0104483	1-31-12		

SCALE: 4:1		DR. BY	DATE
DO NOT SCALE DRAWING		MMM	1-17-06
TITLE: MICROPHONE		CK. BY	DATE
OUTLINE DRAWING		GJP	1-19-06
TD-24610-000		APP. BY	DATE
SHT 1.1		GJP	1-19-06

**KNOWLES ELECTRONICS**  
ITASCA, ILLINOIS U.S.A.

SENSITIVITY IN dB RELATIVE TO 1.0 VOLT/0.1 Pa (N/M<sup>2</sup>)  
FOR CONDITIONS SHOWN BELOW.

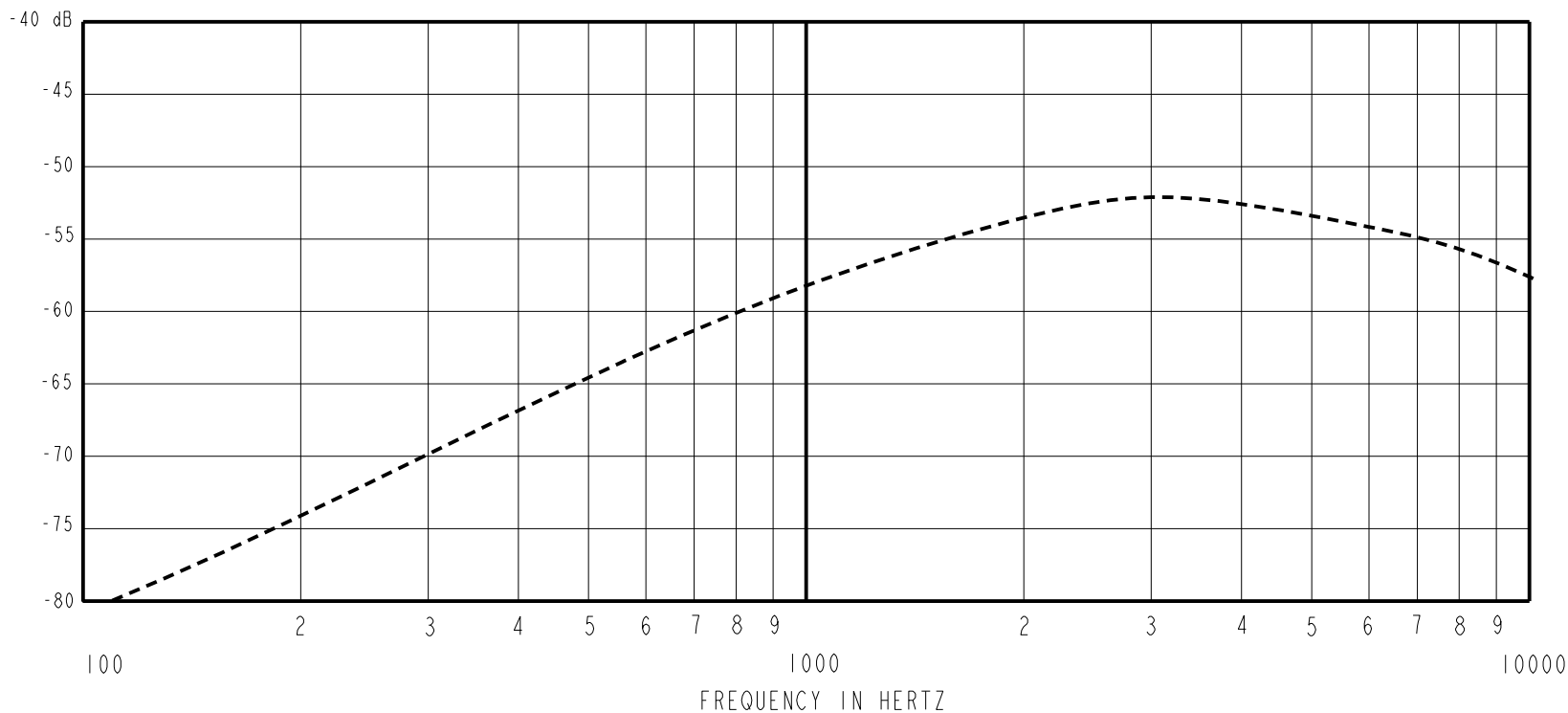

FREQUENCY	SENSITIVITY			DEVICE CONFORMITY	
	MIN.	NOM.	MAX.	RANGE OF DEVIATION FROM 1KHz	
100	---	-68.0	---	-13.5	-2.5
1000	-60.5	-57.5	-54.5	0.0	0.0
~9500	---	-50.0	---	+4.0	+10.0

INTERNAL DELAY	8μS	11μS	14μS
----------------	-----	------	------

- NOTES:
1. CASE CONNECTED TO NEGATIVE TERMINAL.
  2. MICROPHONE TO BE FUNCTIONAL WITH 1.6 VDC SUPPLY.
  3. TYPICAL SENSITIVITY TO HUMIDITY AT 1000Hz IS 0.07 dB/%RH
  4. SENSITIVITY AND NOISE VALUES INDICATED ON THIS SPECIFICATION ARE VALID AT 50% HUMIDITY.
  5. MICROPHONE TESTED WITH REAR PORT BLOCKED.

PORT LOCATION	DC SUPPLY	AMPLIFIER CURRENT DRAIN	SENSITIVITY CHANGE ON REDUCING SUPPLY TO 0.9VDC	"A" WEIGHTED NOISE (dB re 1Vrms)	OUTPUT IMPEDANCE OHMS		
					MIN.	NOM.	MAX.
12C, 12KP	1.3V	50 μA MAX.	3 dB MAX.	-98.0 dB MAX.	2800	4400	6800

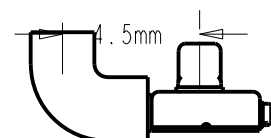
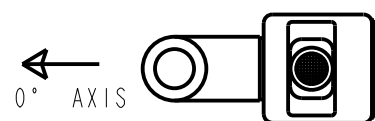

SCALE 4:1

Revision	C.O. #	Implementation Date	RELEASE LEVEL	REVISION
H	M10105050	5-20-13	Active	H
G	M10104483	1-31-12		

**KNOWLES ELECTRONICS**  
ITASCA, ILLINOIS U.S.A.

WHEN TEST LIMITS ARE USED TO ESTABLISH INCOMING INSPECTION ACCEPTANCE/REJECTION CRITERIA, CORRELATION OF TEST EQUIPMENT WITH KNOWLES IS ALSO REQUIRED FOR ELIMINATION OF EQUIPMENT AND TEST METHOD VARIATION

TITLE: **MICROPHONE**  
PERFORMANCE SPECIFICATION

**TD-24610-000**  
SHT 2.1

DR. BY	DATE
MMM	1-17-06
CK. BY	DATE
GJP	1-19-06
APP. BY	DATE
GJP	1-19-06