

# CLIFF

## USB2.0 A-B FEEDTHROUGH CONNECTOR

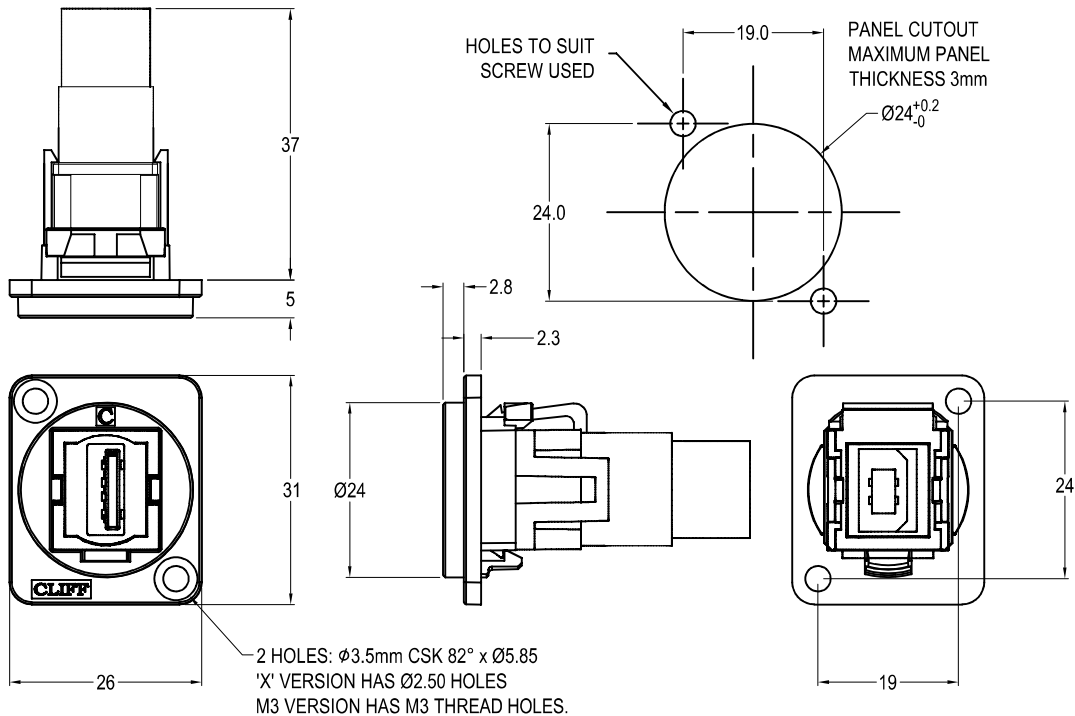

### Feedthrough Features

- Fits standard XLR  $\text{Ø}24\text{mm}$  cutout.
- No soldering or punch termination. Use standard cable for each connector style.
- Front or rear mounted.
- Low rear profile

### General:

Please note: Functionality is affected by cable quality, length and cable wiring configuration.

### VARIANTS

#### Part No.

<b>CP30209N</b>	USB2.0 A-B Black plastic frame, CSK holes
<b>CP30209NW</b>	USB2.0 A-B White plastic frame, CSK holes
<b>CP30209NM</b>	USB2.0 A-B Nickel plated metal frame, CSK holes
<b>CP30209NM3</b>	USB2.0 A-B Nickel plated metal frame, M3 holes
<b>CP30209NMB</b>	USB2.0 A-B Black metal frame, CSK holes
<b>CP30209NM3B</b>	USB2.0 A-B Black metal frame, M3 holes
<b>CP30209NX</b>	USB2.0 A-B Black plastic frame, PLAIN holes
<b>CP30209NXW</b>	USB2.0 A-B White plastic frame, PLAIN holes

### Material:

1. Insert: ABS
2. Plastic Frame: Polyamide UL94 V-2
3. Metal Frame: Diecast, Black or Nickel plated
4. Inner Overmouldings: PE + PVC
5. Shell: Nickel plated steel
6. Contacts: Gold Plated

### Notes:

1. Voltage rating: 30V AC
2. Current rating: 1.5 A max
3. Contact resistance: 50m $\Omega$  max
4. Insulation resistance: 20M $\Omega$  min
5. Dielectric withstanding voltage: 500V AC
6. Operating Temperature: -20°C to 50°C