



TJA1046V

Dual high-speed CAN transceiver with Standby mode

Rev. 1 — 2 March 2018

Product data sheet

1. General description

The TJA1046V is a dual high-speed CAN transceiver that provides two interfaces between a Controller Area Network (CAN) protocol controller and the physical two-wire CAN-bus. It is composed of two fully independent TJA1044V transceivers. The transceivers are designed for high-speed CAN applications in the automotive industry, providing the differential transmit and receive capability to (a microcontroller with) a CAN protocol controller. The TJA1046V guarantees robust communication at data rates up to 5 Mbit/s as used in, for example, CAN FD networks.

The TJA1046V offers a feature set optimized for 12 V automotive applications and excellent ElectroMagnetic Compatibility (EMC) performance.

Additionally, the TJA1046V features:

- Ideal passive behavior to the CAN-bus when the supply voltage is off
- A very low-current Standby mode with bus wake-up capability
- Excellent EMC performance at speeds up to 500 kbit/s, even without a common mode choke

The HVSON package allows for more than 70 % PCB space saving compared with traditional SO packages. These features make the TJA1046V an excellent choice for networks containing more than one HS-CAN interface requiring a low-power mode with wake-up capability via the CAN-bus, especially for body and gateway control units.

The TJA1046V implements the CAN physical layer as defined in ISO 11898-2:2016 and SAE J2284-1 to SAE J2284-5. Additional timing parameters defining loop delay symmetry are specified. This implementation enables reliable communication in the CAN FD fast phase at data rates up to 5 Mbit/s.

2. Features and benefits

2.1 General

- Two fully independent TJA1044V HS-CAN transceivers combined in a single package
- Fully ISO 11898-2:2016 and SAE J2284-1 to SAE J2284-5 compliant
- Certified according to latest VeLIO (Vehicle LAN Interoperability and Optimization) test requirements
- Timing guaranteed for data rates up to 5 Mbit/s
- Improved TXD to RXD propagation delay of 210 ns
- Very low-current Standby mode with host and bus wake-up capability
- Optimized for use in 12 V automotive systems



- EMC performance satisfies 'Hardware Requirements for LIN, CAN and FlexRay Interfaces in Automotive Applications', Version 1.3, May 2012.
- Leadless HVSON14 package (3.0 mm × 4.5 mm) with improved Automated Optical Inspection (AOI) capability
- Can interface with 3.3 V and 5 V-supplied microcontrollers, provided the microcontroller I/Os are 5 V tolerant.
- AEC-Q100 qualified
- Dark green product (halogen free and Restriction of Hazardous Substances (RoHS) compliant)

2.2 Predictable and fail-safe behavior

- Functional behavior predictable under all supply conditions
- Transceivers disengage from bus when not powered (zero load)
- Transmit Data (TXD) and bus dominant time-out functions
- Internal biasing of TXDx and STBx input pins

2.3 Protection

- High ESD handling capability on the bus pins (8 kV IEC and HBM)
- Bus pins protected against transients in automotive environments
- Undervoltage detection on V_{CCx} pins
- Thermally protected

3. Quick reference data

Table 1. Quick reference data

Symbol	Parameter	Conditions	Min	Typ	Max	Unit
V_{CC}	supply voltage	on pins V_{CC1} and V_{CC2}	4.75	-	5.25	V
$V_{Uvd(stb)}$	standby undervoltage detection voltage	on pins V_{CC1} and V_{CC2}	3.5	4	4.3	V
I_{CC}	supply current	per transceiver:				
		Standby mode	-	10	15	μ A
		Normal mode; bus recessive	2	5	10	mA
	Normal mode; bus dominant	20	45	60	mA	
V_{ESD}	electrostatic discharge voltage	IEC 61000-4-2 on pins CANH1, CANH2, CANL1 and CANL2	-8	-	+8	kV
V_{CANH}	voltage on pin CANH	pins CANH1 and CANH2; limiting value according to IEC60134	-42	-	+42	V
V_{CANL}	voltage on pin CANL	pins CANL1 and CANL2; limiting value according to IEC60134	-42	-	+42	V
T_{vj}	virtual junction temperature		-40	-	+150	$^{\circ}$ C

4. Ordering information

Table 2. Ordering information

Type number	Package		Version
	Name	Description	
TJA1046VTK	HVSON14	plastic, thermal enhanced very thin small outline package; no leads; 14 terminals; body 3 × 4.5 × 0.85 mm	SOT1086-2

5. Block diagram

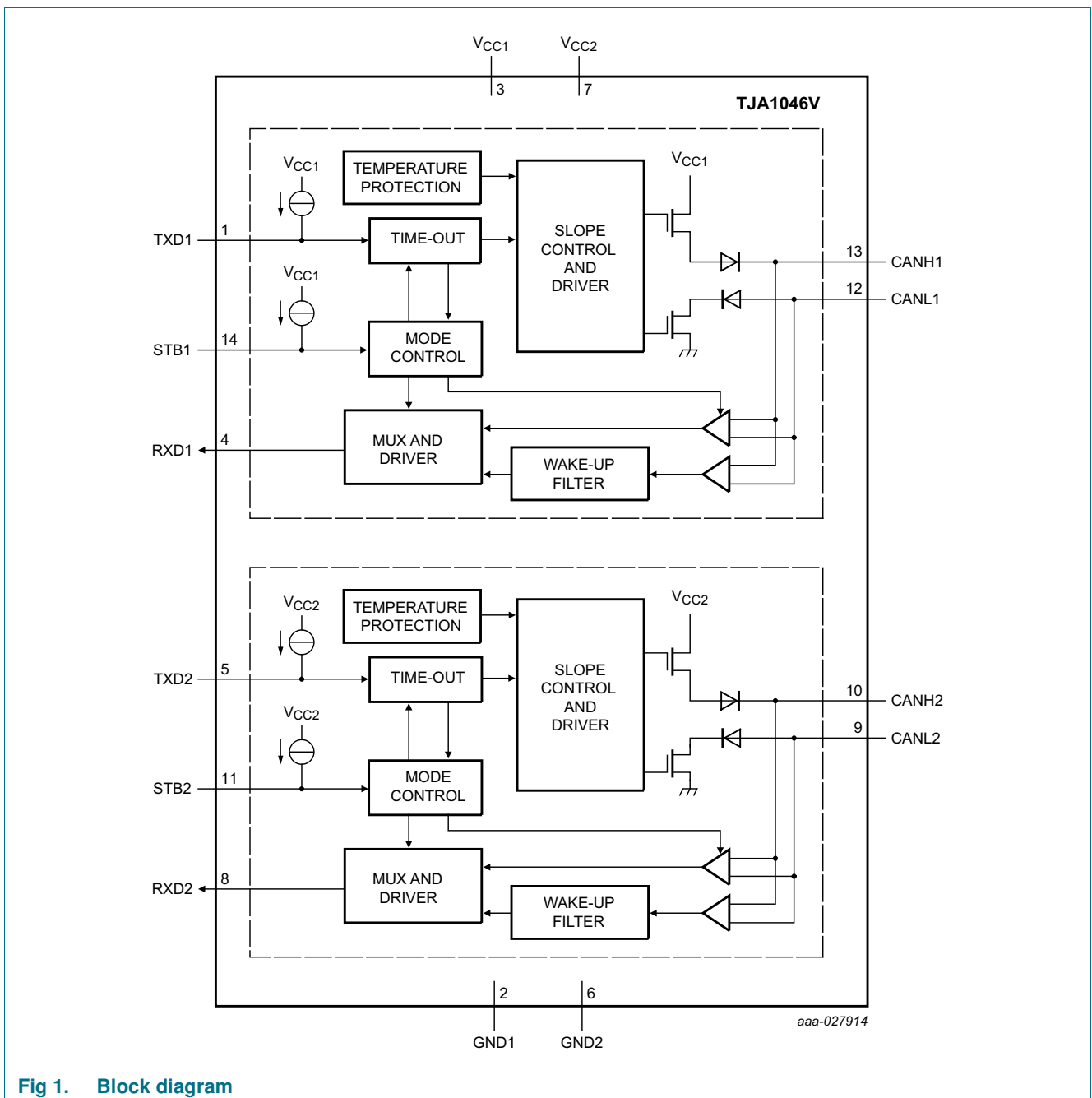
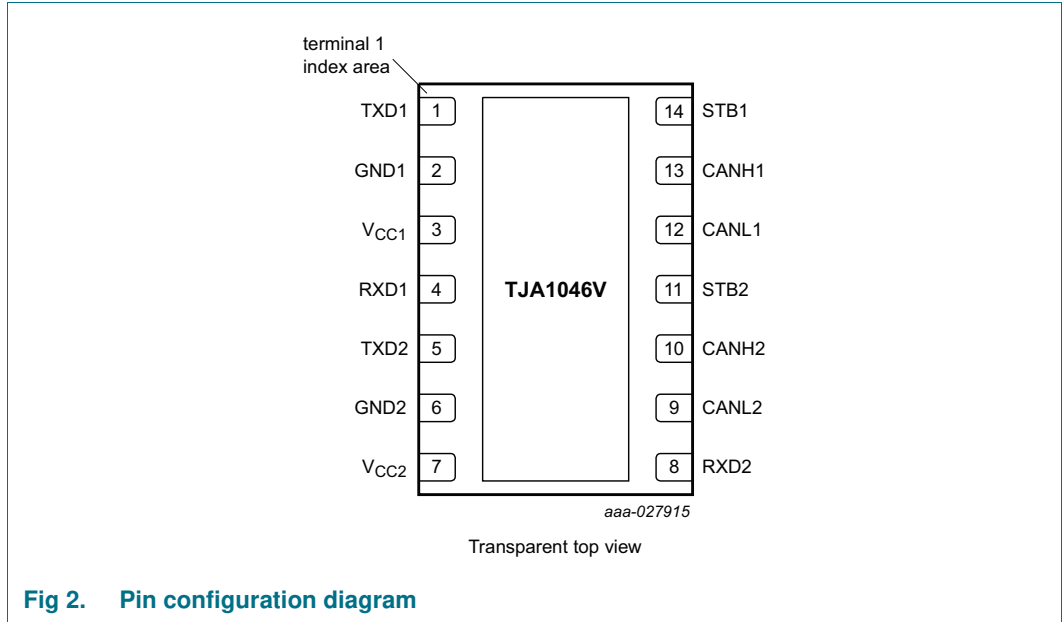

Fig 1. Block diagram

6. Pinning information

6.1 Pinning



6.2 Pin description

Table 3. Pin description

Symbol	Pin	Description
TXD1	1	transmit data input 1
GND1 ^[1]	2	transceiver ground 1
V _{CC1}	3	transceiver supply voltage 1
RXD1	4	receive data output 1; reads out data from the bus lines 1
TXD2	5	transmit data input 2
GND2 ^[1]	6	transceiver ground 2
V _{CC2}	7	transceiver supply voltage 2
RXD2	8	receive data output 2; reads out data from the bus lines 2
CANL2	9	LOW-level CAN-bus line 2
CANH2	10	HIGH-level CAN-bus line 2
STB2	11	Standby mode control input 2
CANL1	12	LOW-level CAN-bus line 1
CANH1	13	HIGH-level CAN-bus line 1
STB1	14	Standby mode control input 1

[1] HVSON14 package die supply ground is connected to both the GNDx pins and the exposed center pad. The GNDx pins must be connected together externally in the application and soldered to board ground. For enhanced thermal and electrical performance, it is recommended that the exposed center pad also be soldered to board ground.

7. Functional description

7.1 Operating modes

The TJA1046V supports two operating modes per transceiver, Normal and Standby. The operating mode is selected independently for each transceiver via pins STB1 and STB2. See [Table 4](#) for a description of the operating modes under normal supply conditions.

Table 4. Operating modes

Mode	Inputs		Outputs	
	Pin STB1/STB2	Pin TXD1/TXD2	CAN driver	Pin RXD1/RXD2
Normal	LOW	LOW	dominant	LOW
		HIGH	recessive	LOW when bus dominant HIGH when bus recessive
Standby	HIGH	x ^[1]	biased to ground	follows BUS when wake-up detected HIGH when no wake-up detected

[1] 'x' = don't care

7.1.1 Normal mode

A LOW level on pin STBx selects Normal mode. In this mode, the enabled transceiver can transmit and receive data via the bus lines CANHx and CANLx (see [Figure 1](#) for the block diagram). The differential receiver converts the analog data on the bus lines into digital data which is output on pin RXDx. The slopes of the output signals on the bus lines are controlled internally and are optimized in a way that guarantees the lowest possible EME.

7.1.2 Standby mode

A HIGH level on pin STBx selects Standby mode. In Standby mode, the enabled transceiver cannot transmit or correctly receive data via the bus lines. The transmitter and Normal-mode receiver blocks are switched off to reduce supply current, and only a low-power differential receiver monitors the bus lines for activity.

In Standby mode, the bus lines are biased to ground to minimize the system supply current. The low-power receiver is supplied from V_{CCX} and is able to detect CAN-bus activity. Pin RXDx follows the bus after a wake-up request has been detected. A transition to Normal mode is triggered when STBx is forced LOW.

7.2 Remote wake-up (via the CAN-bus)

The CAN transceivers contain separate wake-up circuits that operate independently of each other. When a dedicated wake-up pattern (specified in ISO 11898-2: 2016) is detected on the bus, the associated transceiver wakes up from Standby mode. This filtering helps avoid spurious wake-up events. A spurious wake-up sequence could be triggered by, for example, a dominant clamped bus or by dominant phases generated by noise or spikes on the bus.

The wake-up pattern consists of:

- a dominant phase of at least $t_{wake(busdom)}$ followed by
- a recessive phase of at least $t_{wake(busrec)}$ followed by

- a dominant phase of at least $t_{wake(busdom)}$

Dominant or recessive bits inserted between these phases that are shorter than $t_{wake(busdom)}$ and $t_{wake(busrec)}$, respectively, are ignored

The complete dominant-recessive-dominant pattern must be received within $t_{to(wake)bus}$ to be recognized as a valid wake-up pattern (see [Figure 3](#)). Otherwise, the internal wake-up logic is reset. The complete wake-up pattern will then need to be retransmitted to trigger a wake-up event. Pin RXDx remains HIGH until the wake-up event has been triggered.

After a wake-up sequence has been detected, the transceiver will remain in Standby mode with the bus signals reflected on RXDx. Note that dominant or recessive phases lasting less than $t_{filtr(wake)bus}$ will not be detected by the low-power differential receiver and will not be reflected on RXDx in Standby mode.

A wake-up event is not flagged on RXDx if any of the following events occurs while a valid wake-up pattern is being received:

- The transceiver switches to Normal mode
- The complete wake-up pattern was not received within $t_{to(wake)bus}$
- A V_{CC} undervoltage is detected ($V_{CC} < V_{uvd(stb)}$; see [Section 7.3.3](#))

If any of these events occur while a wake sequence is being received, the internal wake-up logic is reset. The complete wake-up sequence will then need to be retransmitted to trigger a wake-up event.

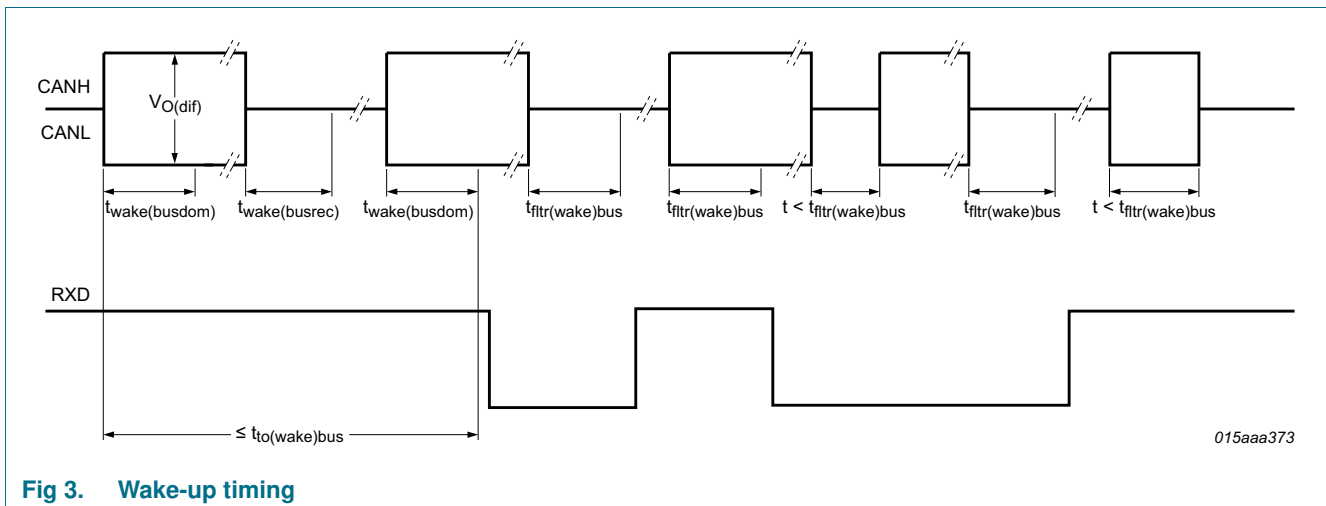

Fig 3. Wake-up timing

7.3 Fail-safe features

7.3.1 TXD dominant time-out function

A 'TXD dominant time-out' timer is started when pin TXDx goes LOW. If the LOW state on this pin persists for longer than $t_{to(dom)TXD}$, the transmitter is disabled, releasing the bus lines to recessive state. This function prevents a hardware and/or software application failure from driving the bus lines to a permanent dominant state (blocking all network communications). The TXD dominant time-out timer is reset when pin TXDx is set HIGH.

The TXD dominant time-out time also defines the minimum possible bit rate of approximately 25 kbit/s. Each of the transceivers in the TJA1046V has its own TXD dominant time-out timer. The two timers operate independently of each other.

7.3.2 Internal biasing of TXDx and STBx input pins

Pins TXDx and STBx have internal pull-ups to V_{CCx} to ensure a safe, defined state in case they are left floating. Pull-up currents flow in these pins in all states; both pins should be held HIGH in Standby mode to minimize supply current.

7.3.3 Undervoltage detection on pins V_{CCx}

The TJA1046V features two fully independent supply voltages. If V_{CCx} drops below the standby undervoltage detection level, $V_{uvd(stb)}$, the transceiver switches to Standby mode. The logic state of pin STBx is ignored until V_{CCx} has recovered. A LOW level on TXDx is also ignored. This precaution prevents the bus being driven dominant while V_{CCx} is recovering. TXDx will continue to be ignored until a HIGH level (bus recessive) is detected.

If V_{CCx} drops below the switch-off undervoltage detection level, $V_{uvd(swoff)}$, the transceiver switches off and disengages from the bus (zero load; bus pins floating) until V_{CCx} has recovered.

Each of the transceivers in the TJA1046V has its own undervoltage protection circuit. The two circuits operate independently of each other.

7.3.4 Overtemperature protection

The output drivers are protected against overtemperature conditions. If the virtual junction temperature exceeds the shutdown junction temperature, $T_{j(sd)}$, both output drivers are disabled. When the virtual junction temperature drops below $T_{j(sd)}$ again, the output drivers recover independently once TXDx has been reset to HIGH. Including the TXDx condition prevents output driver oscillation due to small variations in temperature. Each of the transceivers in the TJA1046V has its own temperature protection circuit. The two circuits operate independently of each other.

8. Limiting values

Table 5. Limiting values

In accordance with the Absolute Maximum Rating System (IEC 60134). All voltages are referenced to GND.

Symbol	Parameter	Conditions	Min	Max	Unit
V _x	voltage on pin x ^[1]	on pins CANH1, CANL1, CANH2, CANL2	-42	+42	V
		on pins V _{CC1} , V _{CC2}	-0.3	+7	V
		on any other pin ^[2]	-0.3	V _{CC} + 0.3	V
V _(CANH-CANL)	voltage between pin CANH and pin CANL		-27	+27	V
V _{trt}	transient voltage	on pins CANH1, CANL1, CANH2, CANL2 ^[3]			
		pulse 1	-100	-	V
		pulse 2a	-	75	V
		pulse 3a	-150	-	V
		pulse 3b	-	100	V
V _{ESD}	electrostatic discharge voltage	IEC 61000-4-2 (150 pF, 330 Ω) ^[4]			
		on pins CANH1, CANL1, CANH2, CANL2	-8	+8	kV
		Human Body Model (HBM); 100 pF, 1.5 kΩ ^[5]			
		on pins CANH1, CANL1, CANH2, CANL2	-8	+8	kV
		on any other pin	-4	+4	kV
		Machine Model (MM); 200 pF, 0.75 μH, 10 Ω ^[6]			
		on any pin	-200	+200	V
		Charged Device Model (CDM); field Induced charge; 4 pF ^[7]			
on corner pins	-750	+750	V		
on any other pin	-500	+500	V		
T _{vj}	virtual junction temperature	^[8]	-40	+150	°C
T _{stg}	storage temperature		-55	+150	°C

- [1] The device can sustain voltages up to the specified values over the product lifetime, provided applied voltages (including transients) never exceed these values.
- [2] Maximum voltage should never exceed 7 V.
- [3] According to IEC TS 62228 (2007), Section 4.2.4; parameters for standard pulses defined in ISO7637 part 2: 2004-06.
- [4] According to IEC TS 62228 (2007), Section 4.3; DIN EN 61000-4-2.
- [5] According to AEC-Q100-002.
- [6] According to AEC-Q100-003.
- [7] According to AEC-Q100-011 Rev-C1. The classification level is C4B.
- [8] In accordance with IEC 60747-1. An alternative definition of virtual junction temperature is: $T_{vj} = T_{amb} + P \times R_{th(vj-a)}$, where $R_{th(vj-a)}$ is a fixed value to be used for the calculation of T_{vj} . The rating for T_{vj} limits the allowable combinations of power dissipation (P) and ambient temperature (T_{amb}).

9. Thermal characteristics

Table 6. Thermal characteristics

Symbol	Parameter	Conditions	Value	Unit
R _{th(j-a)}	thermal resistance from junction to ambient	dual-layer board	[1] 76	K/W
		four-layer board	[2] 46	K/W

- [1] According to JEDEC JESD51-2, JESD51-3 and JESD51-5 at natural convection on 1s board with thermal via array under the exposed pad connected to the second copper layer.
- [2] According to JEDEC JESD51-2, JESD51-5 and JESD51-7 at natural convection on 2s2p board. Board with two inner copper layers (thickness: 35 μm) and thermal via array under the exposed pad connected to the first inner copper layer.

10. Static characteristics

Table 7. Static characteristics

$T_{vj} = -40\text{ °C to }+150\text{ °C}$; $V_{CC} = 4.75\text{ V to }5.25\text{ V}$; $R_L = 60\text{ }\Omega$; $C_L = 100\text{ pF}$ unless specified otherwise; All voltages are defined with respect to ground. Positive currents flow into the IC. [1]

Symbol	Parameter	Conditions	Min	Typ	Max	Unit
Supply; pins V_{CC1} and V_{CC2}						
V _{CC}	supply voltage		4.75	-	5.25	V
V _{uvd(stb)}	standby undervoltage detection voltage		3.5	4	4.3	V
V _{uvd(swoff)}	switch-off undervoltage detection voltage		1.3	2.4	3.4	V
I _{CC}	supply current	per transceiver:				
		Standby mode; V _{TxDx} = V _{CC}	-	10	15	μA
		Normal mode; recessive; V _{TxDx} = V _{CC}	2	5	10	mA
		Normal mode; dominant; V _{TxDx} = 0 V	20	45	60	mA
		Normal mode; dominant; V _{TxDx} = 0 V; short circuit on bus lines; -3 V < (V _{CANH} = V _{CANL}) < +18 V	2	80	110	mA
Standby mode control input; pins STB1 and STB2						
V _{IH}	HIGH-level input voltage		2	-	V _{CC} + 0.3	V
V _{IL}	LOW-level input voltage		-0.3	-	0.8	V
I _{IH}	HIGH-level input current	per transceiver; V _{STBx} = V _{CC}	-1	-	+1	μA
I _{IL}	LOW-level input current	per transceiver; V _{STBx} = 0 V	-15	-	-1	μA
CAN transmit data input; pins TXD1 and TXD2						
V _{IH}	HIGH-level input voltage		2	-	V _{CC} + 0.3	V
V _{IL}	LOW-level input voltage		-0.3	-	0.8	V
I _{IH}	HIGH-level input current	per transceiver; V _{TxDx} = V _{CCx}	-5	-	+5	μA
I _{IL}	LOW-level input current	per transceiver; V _{TxDx} = 0 V	-260	-150	-70	μA
C _i	input capacitance	[2]	-	5	10	pF
CAN receive data output; pins RXD1 and RXD2						
I _{OH}	HIGH-level output current	per transceiver; V _{RxDx} = V _{CCx} - 0.4 V	-8	-3	-1	mA

Table 7. Static characteristics ...continued

$T_{vj} = -40\text{ }^{\circ}\text{C}$ to $+150\text{ }^{\circ}\text{C}$; $V_{CC} = 4.75\text{ V}$ to 5.25 V ; $R_L = 60\text{ }\Omega$; $C_L = 100\text{ pF}$ unless specified otherwise; All voltages are defined with respect to ground. Positive currents flow into the IC.[\[1\]](#)

Symbol	Parameter	Conditions	Min	Typ	Max	Unit
I_{OL}	LOW-level output current	per transceiver; $V_{RDX} = 0.4\text{ V}$; bus dominant	1	-	12	mA
Bus lines; pins CANH1, CANL1, CANH2 and CANL2						
$V_{O(dom)}$	dominant output voltage	$V_{TXDX} = 0\text{ V}$; $t < t_{to(dom)TXD}$				
		pin CANHx; $R_L = 50\text{ }\Omega$ to $65\text{ }\Omega$	2.75	3.5	4.5	V
		pin CANLx; $R_L = 50\text{ }\Omega$ to $65\text{ }\Omega$	0.5	1.5	2.25	V
$V_{dom(TX)sym}$	transmitter dominant voltage symmetry	$V_{dom(TX)sym} = V_{CCx} - V_{CANHx} - V_{CANLx}$	-400	-	+400	mV
V_{TXsym}	transmitter voltage symmetry	$V_{TXsym} = V_{CANHx} + V_{CANLx}$; $f_{TXD} = 250\text{ kHz}$, 1 MHz and 2.5 MHz ; $C_{SPLIT} = 4.7\text{ nF}$	[2] [3] 0.9 V_{CC}	-	1.1 V_{CC}	V
$V_{O(dif)}$	differential output voltage	dominant; Normal mode; $V_{TXDX} = 0\text{ V}$; $t < t_{to(dom)TXD}$				
		$R_L = 50\text{ }\Omega$ to $65\text{ }\Omega$	1.5	-	3	V
		$R_L = 45\text{ }\Omega$ to $70\text{ }\Omega$	1.4	-	3.3	V
		$R_L = 2240\text{ }\Omega$	1.5	-	5	V
		recessive; no load				
		Normal mode: $V_{TXDX} = V_{CCx}$	-50	-	+50	mV
		Standby mode	-0.2	-	+0.2	V
$V_{O(rec)}$	recessive output voltage	Normal mode; $V_{TXDX} = V_{CC}$; no load	2	0.5 V_{CC}	3	V
		Standby mode; no load	-0.1	-	+0.1	V
$V_{th(RX)dif}$	differential receiver threshold voltage	$-12\text{ V} \leq V_{CANLx} \leq +12\text{ V}$; $-12\text{ V} \leq V_{CANHx} \leq +12\text{ V}$				
		Normal mode	0.5	-	0.9	V
		Standby mode	0.4	-	1.15	V
$V_{rec(RX)}$	receiver recessive voltage	$-12\text{ V} \leq V_{CANL} \leq +12\text{ V}$; $-12\text{ V} \leq V_{CANH} \leq +12\text{ V}$				
		Normal mode	-4	-	0.5	V
		Standby mode	-4	-	0.4	V
$V_{dom(RX)}$	receiver dominant voltage	$-12\text{ V} \leq V_{CANL} \leq +12\text{ V}$; $-12\text{ V} \leq V_{CANH} \leq +12\text{ V}$				
		Normal mode	0.9	-	9.0	V
		Standby mode	1.15	-	9.0	V
$V_{hys(RX)dif}$	differential receiver hysteresis voltage	$-12\text{ V} \leq V_{CANL} \leq +12\text{ V}$; $-12\text{ V} \leq V_{CANH} \leq +12\text{ V}$; Normal mode	50	-	300	mV
$I_{O(sc)dom}$	dominant short-circuit output current	per transceiver; $V_{TXDX} = 0\text{ V}$; $t < t_{to(dom)TXD}$; $V_{CC} = 5\text{ V}$				
		pin CANHx; $V_{CANHx} = -15\text{ V}$ to $+40\text{ V}$	-100	-70	-40	mA
		pin CANLx; $V_{CANLx} = -15\text{ V}$ to $+40\text{ V}$	40	70	100	mA
$I_{O(sc)rec}$	recessive short-circuit output current	per transceiver; Normal mode; $V_{CANHx} = V_{CANLx} = -27\text{ V}$ to $+32\text{ V}$; $V_{TXDX} = V_{CC}$;	-5	-	+5	mA

Table 7. Static characteristics ...continued

$T_{vj} = -40\text{ }^{\circ}\text{C}$ to $+150\text{ }^{\circ}\text{C}$; $V_{CC} = 4.75\text{ V}$ to 5.25 V ; $R_L = 60\text{ }\Omega$; $C_L = 100\text{ pF}$ unless specified otherwise; All voltages are defined with respect to ground. Positive currents flow into the IC.^[1]

Symbol	Parameter	Conditions	Min	Typ	Max	Unit
I_L	leakage current	per transceiver; $V_{CC} = 0\text{ V}$ or V_{CC} shorted to GND via $47\text{ k}\Omega$; $V_{CANHx} = V_{CANLx} = 5\text{ V}$	-5	-	+5	μA
R_i	input resistance	$-2\text{ V} \leq V_{CANL} \leq +7\text{ V}$; $-2\text{ V} \leq V_{CANH} \leq +7\text{ V}$	[2] 9	15	28	$\text{k}\Omega$
ΔR_i	input resistance deviation	$0\text{ V} \leq V_{CANL} \leq +5\text{ V}$; $0\text{ V} \leq V_{CANH} \leq +5\text{ V}$	[2] -3	-	+3	%
$R_{i(\text{dif})}$	differential input resistance	$-2\text{ V} \leq V_{CANL} \leq +7\text{ V}$; $-2\text{ V} \leq V_{CANH} \leq +7\text{ V}$	[2] 19	30	52	$\text{k}\Omega$
$C_{i(\text{cm})}$	common-mode input capacitance		[2] -	-	20	pF
$C_{i(\text{dif})}$	differential input capacitance		[2] -	-	10	pF
Temperature detection						
$T_{j(\text{sd})}$	shutdown junction temperature		[2] -	185	-	$^{\circ}\text{C}$

- [1] All parameters are guaranteed over the virtual junction temperature range by design. Factory testing uses correlated test conditions to cover the specified temperature and power supply voltage range.
- [2] Not tested in production; guaranteed by design.
- [3] The test circuit used to measure the bus output voltage symmetry (which includes C_{SPLIT}) is shown in [Figure 8](#).

11. Dynamic characteristics

Table 8. Dynamic characteristics

$T_{vj} = -40\text{ }^{\circ}\text{C}$ to $+150\text{ }^{\circ}\text{C}$; $V_{CC} = 4.75\text{ V}$ to 5.25 V ; $R_L = 60\text{ }\Omega$; $C_L = 100\text{ pF}$ unless specified otherwise. All voltages are defined with respect to ground. All values are specified per transceiver.^[1]

Symbol	Parameter	Conditions	Min	Typ	Max	Unit
Transceiver timing; pins CANH1, CANH2, CANL1, CANL2, TXD1, TXD2, RXD1 and RXD2; see Figure 7 and Figure 4						
$t_{d(\text{TXD-busdom})}$	delay time from TXD to bus dominant	Normal mode	-	65	-	ns
$t_{d(\text{TXD-busrec})}$	delay time from TXD to bus recessive	Normal mode	-	90	-	ns
$t_{d(\text{busdom-RXD})}$	delay time from bus dominant to RXD	Normal mode	-	60	-	ns
$t_{d(\text{busrec-RXD})}$	delay time from bus recessive to RXD	Normal mode	-	65	-	ns
$t_{d(\text{TXDL-RXDL})}$	delay time from TXD LOW to RXD LOW	Normal mode	50	-	210	ns
		Normal mode; $R_L = 120\text{ }\Omega$; $C_L = 200\text{ pF}$	^[2] -	-	300	ns
$t_{d(\text{TXDH-RXDH})}$	delay time from TXD HIGH to RXD HIGH	Normal mode	50	-	210	ns
		Normal mode; $R_L = 120\text{ }\Omega$; $C_L = 200\text{ pF}$	^[2] -	-	300	ns
$t_{\text{bit}(\text{bus})}$	transmitted recessive bit width	$t_{\text{bit}(\text{TXD})} = 500\text{ ns}$	^[3] 435	-	530	ns
		$t_{\text{bit}(\text{TXD})} = 200\text{ ns}$	^[3] 155	-	210	ns
$t_{\text{bit}(\text{RXD})}$	bit time on pin RXD	$t_{\text{bit}(\text{TXD})} = 500\text{ ns}$	^[3] 400	-	550	ns
		$t_{\text{bit}(\text{TXD})} = 200\text{ ns}$	^[3] 120	-	220	ns
Δt_{rec}	receiver timing symmetry	$t_{\text{bit}(\text{TXD})} = 500\text{ ns}$	-65	-	+40	ns
		$t_{\text{bit}(\text{TXD})} = 200\text{ ns}$	-45	-	+15	ns
$t_{\text{to}(\text{dom})\text{TXD}}$	TXD dominant time-out time	$V_{\text{TXDx}} = 0\text{ V}$; Normal mode	0.8	3	6.5	ms
$t_{d(\text{stb-norm})}$	standby to normal mode delay time		7	25	47	μs
$t_{\text{wake}(\text{busdom})}$	bus dominant wake-up time	Standby mode	0.5	-	3	μs
$t_{\text{wake}(\text{busrec})}$	bus recessive wake-up time	Standby mode	0.5	-	3	μs
$t_{\text{to}(\text{wake})\text{bus}}$	bus wake-up time-out time	Standby mode	0.8	3	6.5	ms
$t_{\text{ftr}(\text{wake})\text{bus}}$	bus wake-up filter time	Standby mode	0.5	1	3	μs

[1] All parameters are guaranteed over the virtual junction temperature range by design. Factory testing uses correlated test conditions to cover the specified temperature and power supply voltage range.

[2] Not tested in production; guaranteed by design.

[3] See [Figure 5](#).

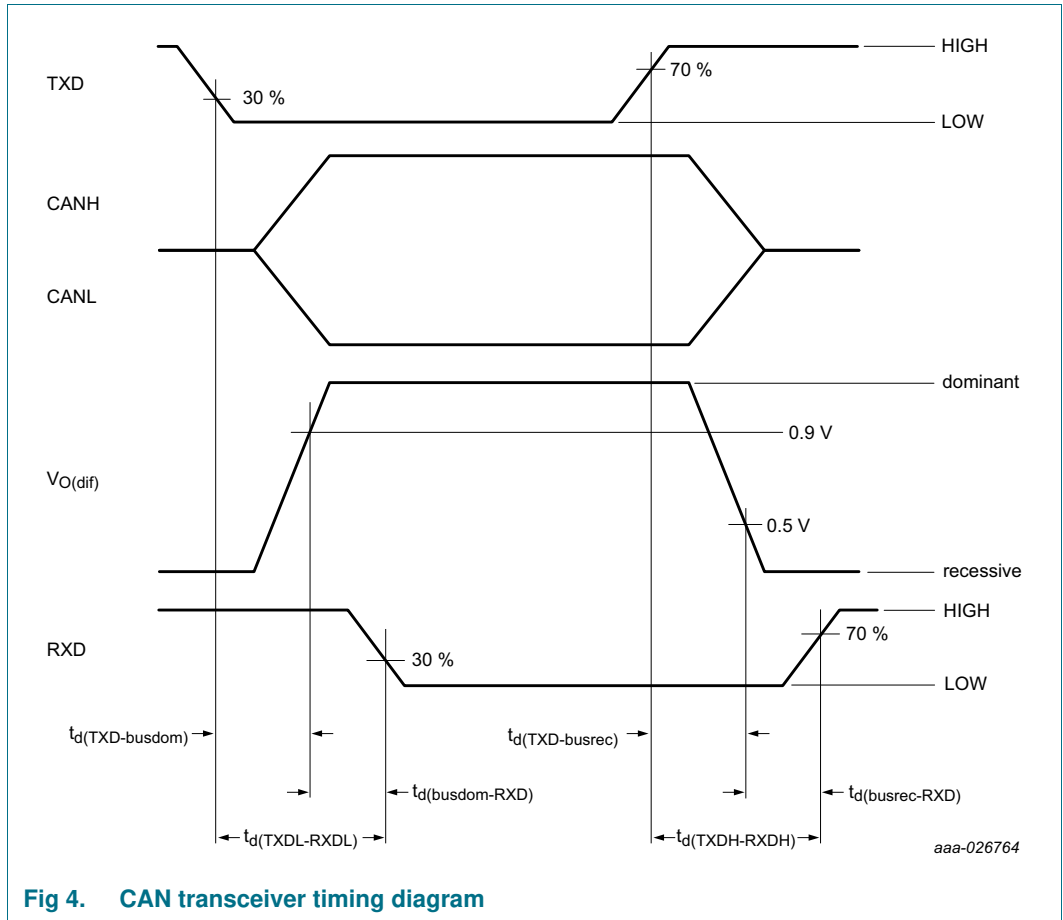

Fig 4. CAN transceiver timing diagram

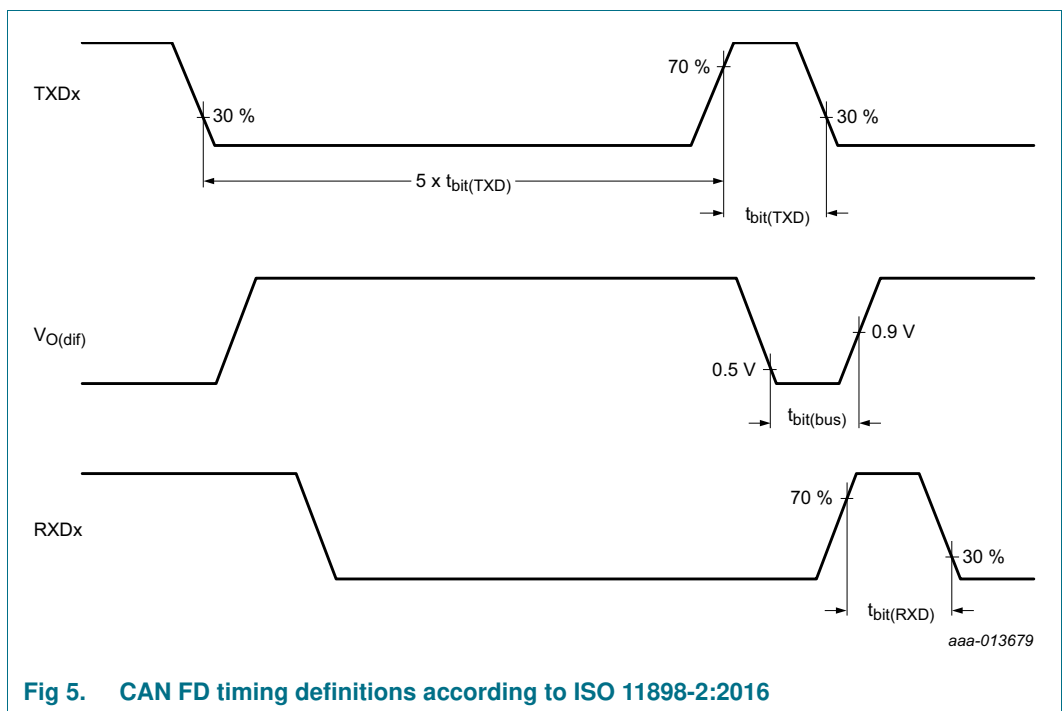
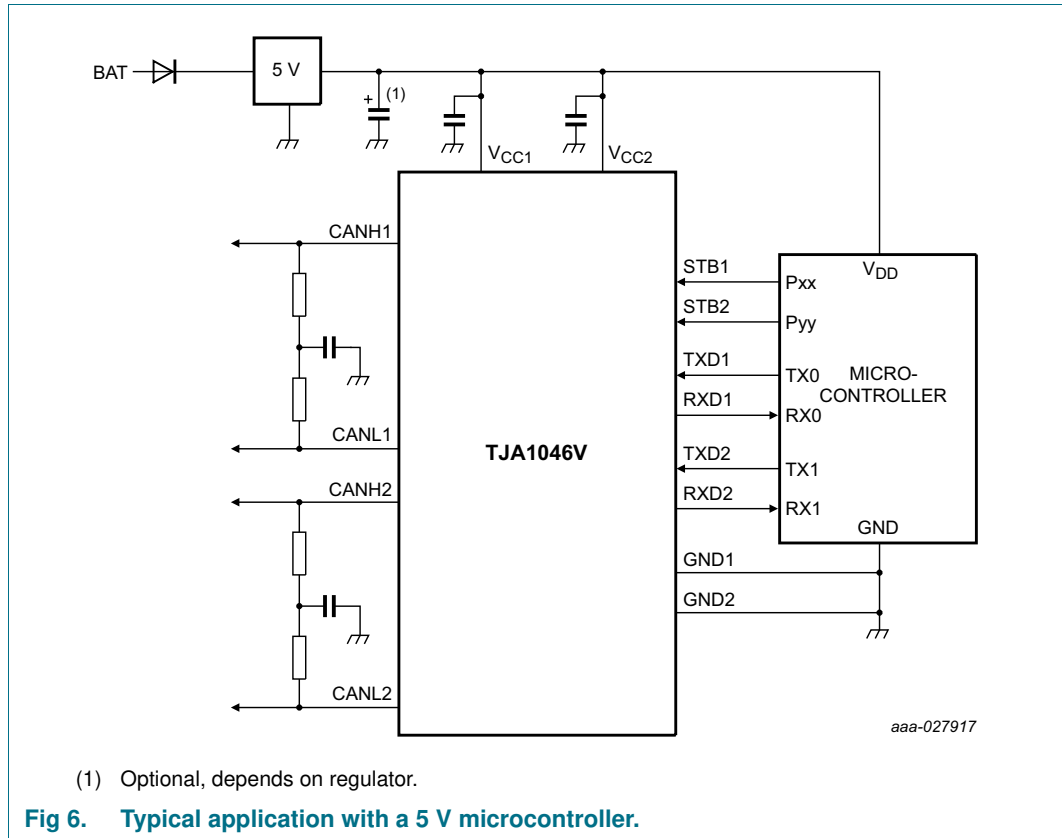

Fig 5. CAN FD timing definitions according to ISO 11898-2:2016

12. Application information

12.1 Application diagram



12.2 Application hints

Further information on the application of the TJA1046V can be found in NXP application hints AH1308 'Application Hints - Standalone high speed CAN transceivers Mantis TJA1044/TJA1057 and Dual-Mantis TJA1046'.

13. Test information

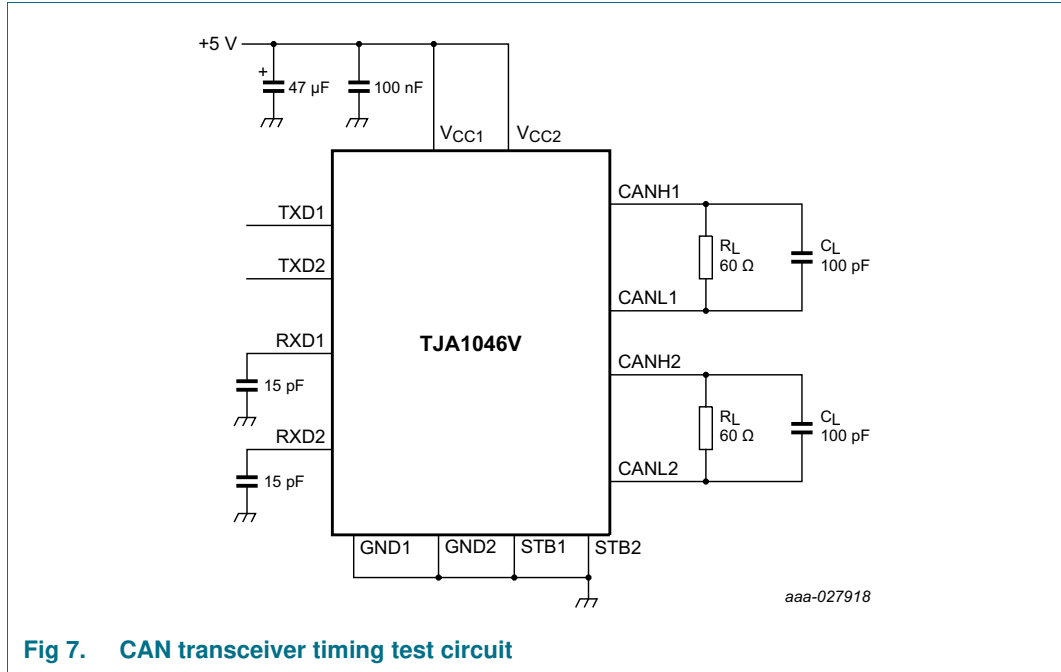

Fig 7. CAN transceiver timing test circuit

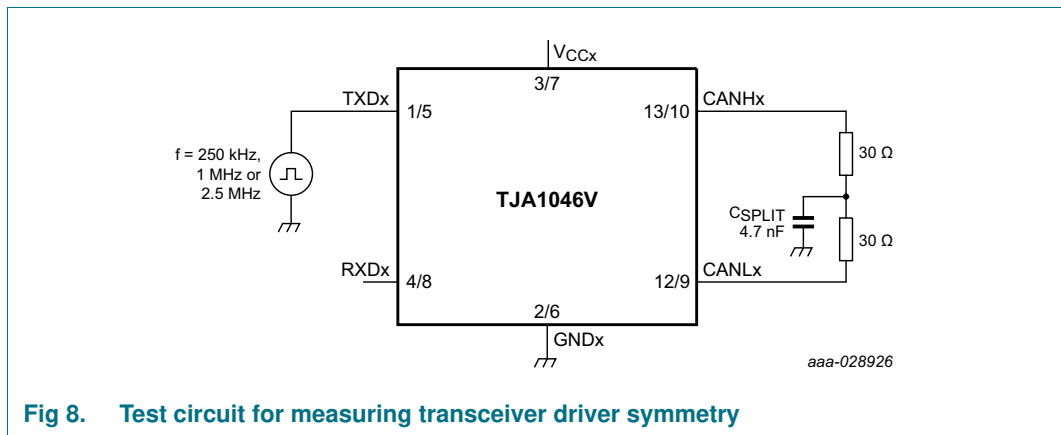

Fig 8. Test circuit for measuring transceiver driver symmetry

13.1 Quality information

This product has been qualified in accordance with the Automotive Electronics Council (AEC) standard *Q100 Rev-G - Failure mechanism based stress test qualification for integrated circuits*, and is suitable for use in automotive applications.

14. Package outline

HVSON14: plastic, thermal enhanced very thin small outline package; no leads; 14 terminals; body 3 x 4.5 x 0.85 mm

SOT1086-2

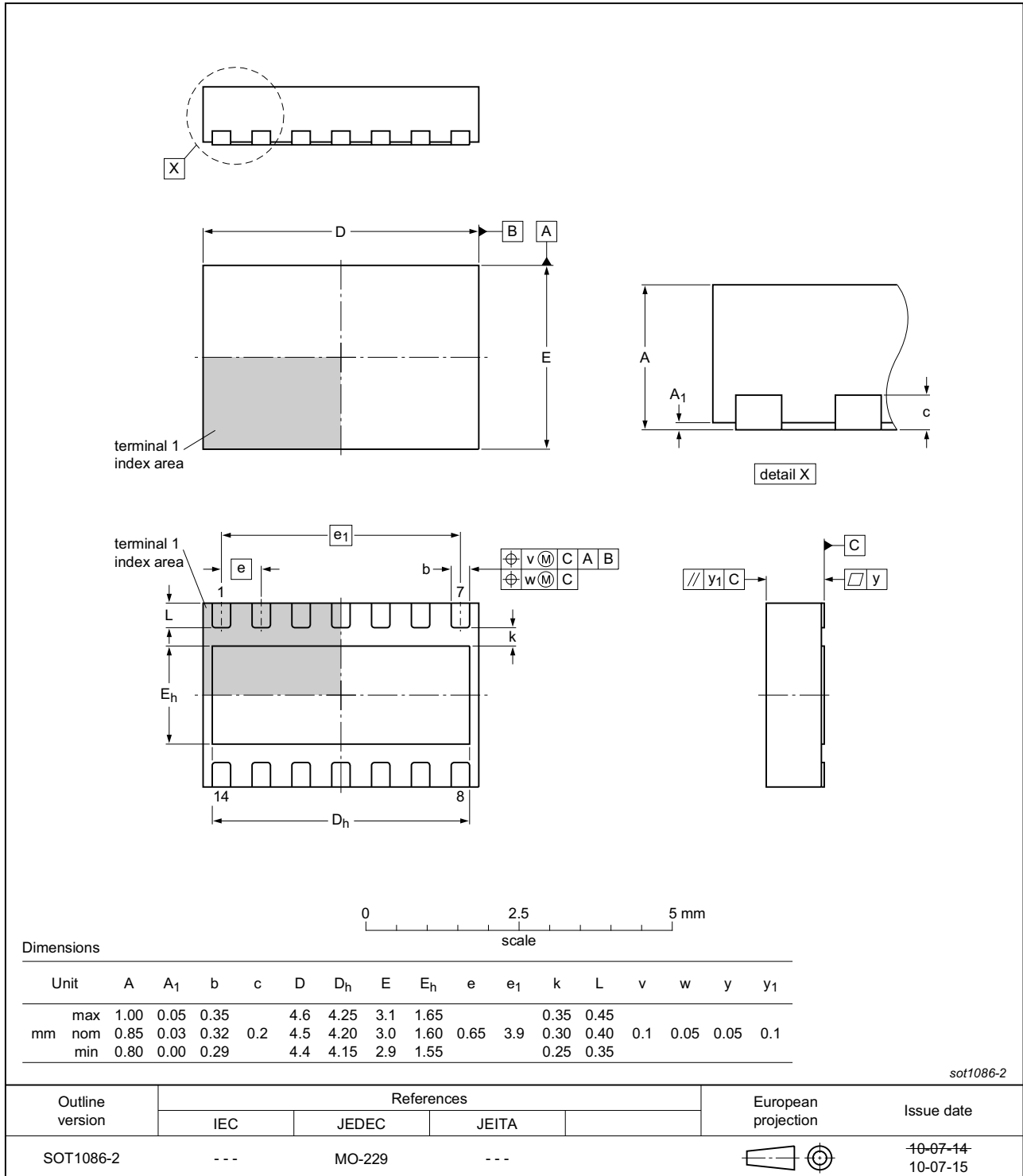

Fig 9. Package outline SOT1086-2 (HVSON14)

15. Handling information

All input and output pins are protected against ElectroStatic Discharge (ESD) under normal handling. When handling ensure that the appropriate precautions are taken as described in *JESD625-A* or equivalent standards.

16. Soldering of SMD packages

This text provides a very brief insight into a complex technology. A more in-depth account of soldering ICs can be found in Application Note *AN10365 "Surface mount reflow soldering description"*.

16.1 Introduction to soldering

Soldering is one of the most common methods through which packages are attached to Printed Circuit Boards (PCBs), to form electrical circuits. The soldered joint provides both the mechanical and the electrical connection. There is no single soldering method that is ideal for all IC packages. Wave soldering is often preferred when through-hole and Surface Mount Devices (SMDs) are mixed on one printed wiring board; however, it is not suitable for fine pitch SMDs. Reflow soldering is ideal for the small pitches and high densities that come with increased miniaturization.

16.2 Wave and reflow soldering

Wave soldering is a joining technology in which the joints are made by solder coming from a standing wave of liquid solder. The wave soldering process is suitable for the following:

- Through-hole components
- Leaded or leadless SMDs, which are glued to the surface of the printed circuit board

Not all SMDs can be wave soldered. Packages with solder balls, and some leadless packages which have solder lands underneath the body, cannot be wave soldered. Also, leaded SMDs with leads having a pitch smaller than ~0.6 mm cannot be wave soldered, due to an increased probability of bridging.

The reflow soldering process involves applying solder paste to a board, followed by component placement and exposure to a temperature profile. Leaded packages, packages with solder balls, and leadless packages are all reflow solderable.

Key characteristics in both wave and reflow soldering are:

- Board specifications, including the board finish, solder masks and vias
- Package footprints, including solder thieves and orientation
- The moisture sensitivity level of the packages
- Package placement
- Inspection and repair
- Lead-free soldering versus SnPb soldering

16.3 Wave soldering

Key characteristics in wave soldering are:

- Process issues, such as application of adhesive and flux, clinching of leads, board transport, the solder wave parameters, and the time during which components are exposed to the wave
- Solder bath specifications, including temperature and impurities

16.4 Reflow soldering

Key characteristics in reflow soldering are:

- Lead-free versus SnPb soldering; note that a lead-free reflow process usually leads to higher minimum peak temperatures (see [Figure 10](#)) than a SnPb process, thus reducing the process window
- Solder paste printing issues including smearing, release, and adjusting the process window for a mix of large and small components on one board
- Reflow temperature profile; this profile includes preheat, reflow (in which the board is heated to the peak temperature) and cooling down. It is imperative that the peak temperature is high enough for the solder to make reliable solder joints (a solder paste characteristic). In addition, the peak temperature must be low enough that the packages and/or boards are not damaged. The peak temperature of the package depends on package thickness and volume and is classified in accordance with [Table 9](#) and [10](#)

Table 9. SnPb eutectic process (from J-STD-020D)

Package thickness (mm)	Package reflow temperature (°C)	
	Volume (mm ³)	
	< 350	≥ 350
< 2.5	235	220
≥ 2.5	220	220

Table 10. Lead-free process (from J-STD-020D)

Package thickness (mm)	Package reflow temperature (°C)		
	Volume (mm ³)		
	< 350	350 to 2000	> 2000
< 1.6	260	260	260
1.6 to 2.5	260	250	245
> 2.5	250	245	245

Moisture sensitivity precautions, as indicated on the packing, must be respected at all times.

Studies have shown that small packages reach higher temperatures during reflow soldering, see [Figure 10](#).

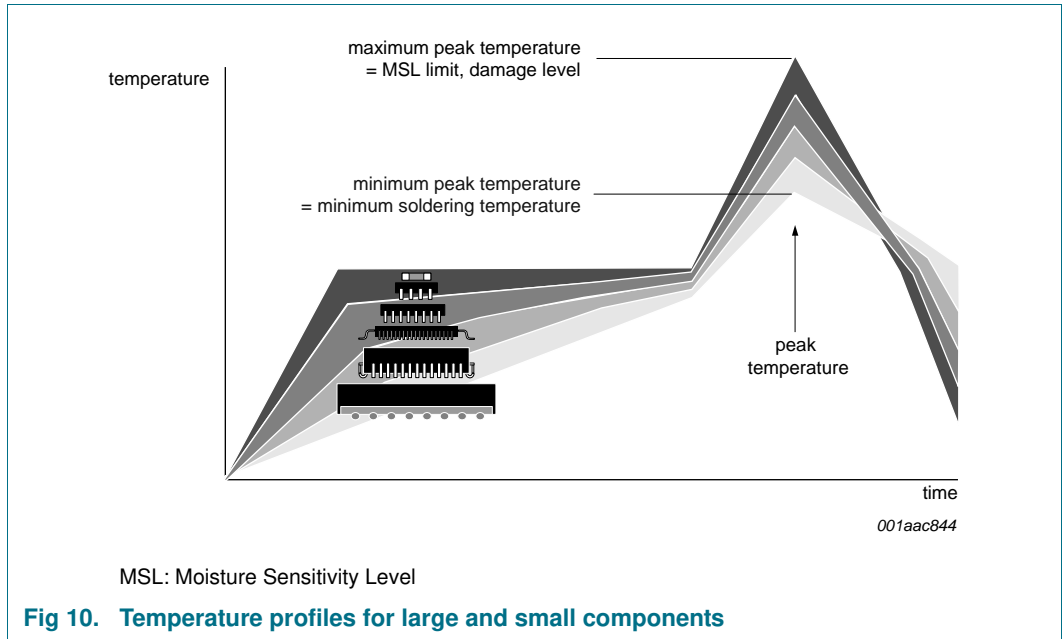

For further information on temperature profiles, refer to Application Note AN10365 “Surface mount reflow soldering description”.

17. Appendix: ISO 11898-2:2016 parameter cross-reference list

Table 11. ISO 11898-2:2016 to NXP data sheet parameter conversion

ISO 11898-2:2016		NXP data sheet	
Parameter	Notation	Symbol	Parameter
HS-PMA dominant output characteristics			
Single ended voltage on CAN_H	V_{CAN_H}	$V_{O(dom)}$	dominant output voltage
Single ended voltage on CAN_L	V_{CAN_L}		
Differential voltage on normal bus load	V_{Diff}	$V_{O(dif)}$	differential output voltage
Differential voltage on effective resistance during arbitration			
Optional: Differential voltage on extended bus load range			
HS-PMA driver symmetry			
Driver symmetry	V_{SYM}	V_{TXsym}	transmitter voltage symmetry
Maximum HS-PMA driver output current			
Absolute current on CAN_H	I_{CAN_H}	$I_{O(sc)dom}$	dominant short-circuit output current
Absolute current on CAN_L	I_{CAN_L}		
HS-PMA recessive output characteristics, bus biasing active/inactive			
Single ended output voltage on CAN_H	V_{CAN_H}	$V_{O(rec)}$	recessive output voltage
Single ended output voltage on CAN_L	V_{CAN_L}		
Differential output voltage	V_{Diff}	$V_{O(dif)}$	differential output voltage
Optional HS-PMA transmit dominant timeout			
Transmit dominant timeout, long	t_{dom}	$t_{to(dom)TXD}$	TXD dominant time-out time
Transmit dominant timeout, short			
HS-PMA static receiver input characteristics, bus biasing active/inactive			
Recessive state differential input voltage range	V_{Diff}	$V_{th(RX)dif}$	differential receiver threshold voltage
Dominant state differential input voltage range		$V_{rec(RX)}$	receiver recessive voltage
		$V_{dom(RX)}$	receiver dominant voltage
HS-PMA receiver input resistance (matching)			
Differential internal resistance	R_{Diff}	$R_{i(dif)}$	differential input resistance
Single ended internal resistance	R_{CAN_H} R_{CAN_L}	R_i	input resistance
Matching of internal resistance	MR	ΔR_i	input resistance deviation
HS-PMA implementation loop delay requirement			
Loop delay	t_{Loop}	$t_{d(TXDH-RXDH)}$	delay time from TXD HIGH to RXD HIGH
		$t_{d(TXDL-RXDL)}$	delay time from TXD LOW to RXD LOW
Optional HS-PMA implementation data signal timing requirements for use with bit rates above 1 Mbit/s up to 2 Mbit/s and above 2 Mbit/s up to 5 Mbit/s			
Transmitted recessive bit width @ 2 Mbit/s / @ 5 Mbit/s, intended	$t_{Bit(Bus)}$	$t_{bit(bus)}$	transmitted recessive bit width
Received recessive bit width @ 2 Mbit/s / @ 5 Mbit/s	$t_{Bit(RXD)}$	$t_{bit(RXD)}$	bit time on pin RXD
Receiver timing symmetry @ 2 Mbit/s / @ 5 Mbit/s	Δt_{Rec}	Δt_{rec}	receiver timing symmetry

Table 11. ISO 11898-2:2016 to NXP data sheet parameter conversion

ISO 11898-2:2016		NXP data sheet	
Parameter	Notation	Symbol	Parameter
HS-PMA maximum ratings of V_{CAN_H}, V_{CAN_L} and V_{Diff}			
Maximum rating V _{Diff}	V _{Diff}	V _(CANH-CANL)	voltage between pin CANH and pin CANL
General maximum rating V _{CAN_H} and V _{CAN_L}	V _{CAN_H}	V _x	voltage on pin x
Optional: Extended maximum rating V _{CAN_H} and V _{CAN_L}	V _{CAN_L}		
HS-PMA maximum leakage currents on CAN_H and CAN_L, unpowered			
Leakage current on CAN_H, CAN_L	I _{CAN_H} I _{CAN_L}	I _L	leakage current
HS-PMA bus biasing control timings			
CAN activity filter time, long	t _{Filter}	t _{wake(busdom)} ^[1]	bus dominant wake-up time
CAN activity filter time, short		t _{wake(busrec)} ^[1]	bus recessive wake-up time
Wake-up timeout, short	t _{Wake}	t _{to(wake)bus}	bus wake-up time-out time
Wake-up timeout, long			
Timeout for bus inactivity	t _{Silence}	t _{to(silence)}	bus silence time-out time
Bus Bias reaction time	t _{Bias}	t _{d(busact-bias)}	delay time from bus active to bias

[1] t_{fltr(wake)bus} - bus wake-up filter time, in devices with basic wake-up functionality

18. Revision history

Table 12. Revision history

Document ID	Release date	Data sheet status	Change notice	Supersedes
TJA1046V v.1	20180302	Product data sheet	-	-

19. Legal information

19.1 Data sheet status

Document status ^{[1][2]}	Product status ^[3]	Definition
Objective [short] data sheet	Development	This document contains data from the objective specification for product development.
Preliminary [short] data sheet	Qualification	This document contains data from the preliminary specification.
Product [short] data sheet	Production	This document contains the product specification.

[1] Please consult the most recently issued document before initiating or completing a design.

[2] The term 'short data sheet' is explained in section "Definitions".

[3] The product status of device(s) described in this document may have changed since this document was published and may differ in case of multiple devices. The latest product status information is available on the Internet at URL <http://www.nxp.com>.

19.2 Definitions

Draft — The document is a draft version only. The content is still under internal review and subject to formal approval, which may result in modifications or additions. NXP Semiconductors does not give any representations or warranties as to the accuracy or completeness of information included herein and shall have no liability for the consequences of use of such information.

Short data sheet — A short data sheet is an extract from a full data sheet with the same product type number(s) and title. A short data sheet is intended for quick reference only and should not be relied upon to contain detailed and full information. For detailed and full information see the relevant full data sheet, which is available on request via the local NXP Semiconductors sales office. In case of any inconsistency or conflict with the short data sheet, the full data sheet shall prevail.

Product specification — The information and data provided in a Product data sheet shall define the specification of the product as agreed between NXP Semiconductors and its customer, unless NXP Semiconductors and customer have explicitly agreed otherwise in writing. In no event however, shall an agreement be valid in which the NXP Semiconductors product is deemed to offer functions and qualities beyond those described in the Product data sheet.

19.3 Disclaimers

Limited warranty and liability — Information in this document is believed to be accurate and reliable. However, NXP Semiconductors does not give any representations or warranties, expressed or implied, as to the accuracy or completeness of such information and shall have no liability for the consequences of use of such information. NXP Semiconductors takes no responsibility for the content in this document if provided by an information source outside of NXP Semiconductors.

In no event shall NXP Semiconductors be liable for any indirect, incidental, punitive, special or consequential damages (including - without limitation - lost profits, lost savings, business interruption, costs related to the removal or replacement of any products or rework charges) whether or not such damages are based on tort (including negligence), warranty, breach of contract or any other legal theory.

Notwithstanding any damages that customer might incur for any reason whatsoever, NXP Semiconductors' aggregate and cumulative liability towards customer for the products described herein shall be limited in accordance with the *Terms and conditions of commercial sale* of NXP Semiconductors.

Right to make changes — NXP Semiconductors reserves the right to make changes to information published in this document, including without limitation specifications and product descriptions, at any time and without notice. This document supersedes and replaces all information supplied prior to the publication hereof.

Suitability for use in automotive applications — This NXP Semiconductors product has been qualified for use in automotive applications. Unless otherwise agreed in writing, the product is not designed, authorized or warranted to be suitable for use in life support, life-critical or safety-critical systems or equipment, nor in applications where failure or malfunction of an NXP Semiconductors product can reasonably be expected to result in personal injury, death or severe property or environmental damage. NXP Semiconductors and its suppliers accept no liability for inclusion and/or use of NXP Semiconductors products in such equipment or applications and therefore such inclusion and/or use is at the customer's own risk.

Applications — Applications that are described herein for any of these products are for illustrative purposes only. NXP Semiconductors makes no representation or warranty that such applications will be suitable for the specified use without further testing or modification.

Customers are responsible for the design and operation of their applications and products using NXP Semiconductors products, and NXP Semiconductors accepts no liability for any assistance with applications or customer product design. It is customer's sole responsibility to determine whether the NXP Semiconductors product is suitable and fit for the customer's applications and products planned, as well as for the planned application and use of customer's third party customer(s). Customers should provide appropriate design and operating safeguards to minimize the risks associated with their applications and products.

NXP Semiconductors does not accept any liability related to any default, damage, costs or problem which is based on any weakness or default in the customer's applications or products, or the application or use by customer's third party customer(s). Customer is responsible for doing all necessary testing for the customer's applications and products using NXP Semiconductors products in order to avoid a default of the applications and the products or of the application or use by customer's third party customer(s). NXP does not accept any liability in this respect.

Limiting values — Stress above one or more limiting values (as defined in the Absolute Maximum Ratings System of IEC 60134) will cause permanent damage to the device. Limiting values are stress ratings only and (proper) operation of the device at these or any other conditions above those given in the Recommended operating conditions section (if present) or the Characteristics sections of this document is not warranted. Constant or repeated exposure to limiting values will permanently and irreversibly affect the quality and reliability of the device.

Terms and conditions of commercial sale — NXP Semiconductors products are sold subject to the general terms and conditions of commercial sale, as published at <http://www.nxp.com/profile/terms>, unless otherwise agreed in a valid written individual agreement. In case an individual agreement is concluded only the terms and conditions of the respective agreement shall apply. NXP Semiconductors hereby expressly objects to applying the customer's general terms and conditions with regard to the purchase of NXP Semiconductors products by customer.

No offer to sell or license — Nothing in this document may be interpreted or construed as an offer to sell products that is open for acceptance or the grant, conveyance or implication of any license under any copyrights, patents or other industrial or intellectual property rights.

Export control — This document as well as the item(s) described herein may be subject to export control regulations. Export might require a prior authorization from competent authorities.

Quick reference data — The Quick reference data is an extract of the product data given in the Limiting values and Characteristics sections of this document, and as such is not complete, exhaustive or legally binding.

Translations — A non-English (translated) version of a document is for reference only. The English version shall prevail in case of any discrepancy between the translated and English versions.

19.4 Trademarks

Notice: All referenced brands, product names, service names and trademarks are the property of their respective owners.

Mantis — is a trademark of NXP B.V.

20. Contact information

For more information, please visit: <http://www.nxp.com>

For sales office addresses, please send an email to: salesaddresses@nxp.com

21. Contents

1	General description	1	19.4	Trademarks	24
2	Features and benefits	1	20	Contact information	24
2.1	General	1	21	Contents	25
2.2	Predictable and fail-safe behavior	2			
2.3	Protection	2			
3	Quick reference data	2			
4	Ordering information	3			
5	Block diagram	3			
6	Pinning information	4			
6.1	Pinning	4			
6.2	Pin description	4			
7	Functional description	5			
7.1	Operating modes	5			
7.1.1	Normal mode	5			
7.1.2	Standby mode	5			
7.2	Remote wake-up (via the CAN-bus)	5			
7.3	Fail-safe features	6			
7.3.1	TXD dominant time-out function	6			
7.3.2	Internal biasing of TXDx and STBx input pins	7			
7.3.3	Undervoltage detection on pins V_{CCx}	7			
7.3.4	Overtemperature protection	7			
8	Limiting values	8			
9	Thermal characteristics	9			
10	Static characteristics	9			
11	Dynamic characteristics	12			
12	Application information	14			
12.1	Application diagram	14			
12.2	Application hints	14			
13	Test information	15			
13.1	Quality information	15			
14	Package outline	16			
15	Handling information	17			
16	Soldering of SMD packages	17			
16.1	Introduction to soldering	17			
16.2	Wave and reflow soldering	17			
16.3	Wave soldering	17			
16.4	Reflow soldering	18			
17	Appendix: ISO 11898-2:2016 parameter cross-reference list	20			
18	Revision history	22			
19	Legal information	23			
19.1	Data sheet status	23			
19.2	Definitions	23			
19.3	Disclaimers	23			

Please be aware that important notices concerning this document and the product(s) described herein, have been included in section 'Legal information'.

© NXP Semiconductors N.V. 2018.

All rights reserved.

For more information, please visit: <http://www.nxp.com>

For sales office addresses, please send an email to: salesaddresses@nxp.com

Date of release: 2 March 2018

Document identifier: TJA1046V