

CDE

Lighting Capacitors

FILM CAPACITORS FOR HIGH
INTENSITY DISCHARGE (HID)
AND SIGN BALLAST LIGHTING

RoHS COMPLIANT



Intelligent Capacitor Solutions



High quality and long life characterize Cornell Dubilier film capacitors for HID and sign ballast lighting applications. Like all CDE products, our rugged, reliable capacitors are constructed using high quality materials and Lean Six Sigma manufacturing practices. These capacitors undergo 100% outgoing electrical and visual testing, and representative UL fault current, environmental and accelerated life testing (ALT)* as part of our quality assurance process.

CDE maintains manufacturing facilities in China and India to enable quick turn-around for shipping and delivery worldwide. If you have specialized needs, our flexible manufacturing processes allow us to quickly provide custom configurations. For emergency lighting applications, please see our axial wrap and fill capacitor line.

*Accelerated life testing (ALT) is performed for 2000 hours at 125% voltage rating and temperature at 105°C.



CDE provides intelligent capacitor solutions.



Lighting Capacitors

FILM CAPACITORS FOR HIGH INTENSITY DISCHARGE (HID) AND SIGN BALLAST LIGHTING



Applications

- Area Lighting
- HID Magnetic Ballast Kits for Greenhouses or Hydroponics
- High / Low Bay / Warehousing
- Horticultural Lighting
- Parking Lot Installations
- Sign Ballast Kits
- Sports Lighting
- Street Lamp Fixtures
- Street Lighting

CDE produces both oil-filled and dry capacitors for the HID and sign ballast lighting markets. Constructed with film designed to withstand the rigors of the application, these units are built to operate up to 105°C.

HID lighting capacitors are built with a $\pm 3\%$ tolerance on capacitance, and are designed to operate for a minimum of 60,000 hours. Sign ballast capacitors are constructed with film/foil technology and have tolerances based on application requirements.

Highlights

- Made to EIA-456-A standards
- Metal or plastic case
- Wet or dry construction
- Life test temperature to 105°C
- 18 AWG wire lead termination
- RoHS compliant
- Dual rated HID
- Dual or triple value caps for sign ballasts
- UL-810 fault current protection

Specifications

Capacitance Range:	1 to 75 μF for HID; 1.4 to 2.6 μF with dual or triple rating for sign ballasts
HID Capacitance Tolerance:	$\pm 3\%$
AC Voltage Range:	120 VAC to 660 VAC for HID; 550 VAC to 1,200 VAC for sign ballasts
Temperature Range:	-40°C to +105°C for HID; 0°C to +85°C for sign ballasts
Approval Certification:	UL, cUL UL construction only for dry HID



**CORNELL
DUBILIER**

1605 E. Rodney French Blvd. Tel: 508-996-8561
New Bedford, MA 02745 Fax: 508-996-3830

sales1@cde.com
www.CDE.com

Lighting Capacitors

FILM CAPACITORS FOR HIGH INTENSITY DISCHARGE (HID)
AND SIGN BALLAST LIGHTING

Oval Oil-Filled Case Sizes

Base Size	Description	L Inches	W Inches
A	1¼" Oval	2.16	1.31
B	1½" Oval	2.69	1.56
C	1¾" Oval	2.91	1.91
D	2" Oval	3.66	1.97

Oval Single Cover Configuration

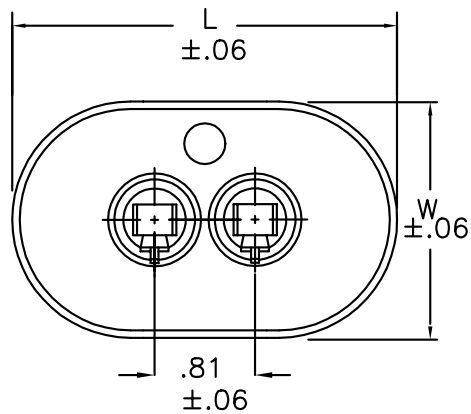

Oval Dual Cover Configuration

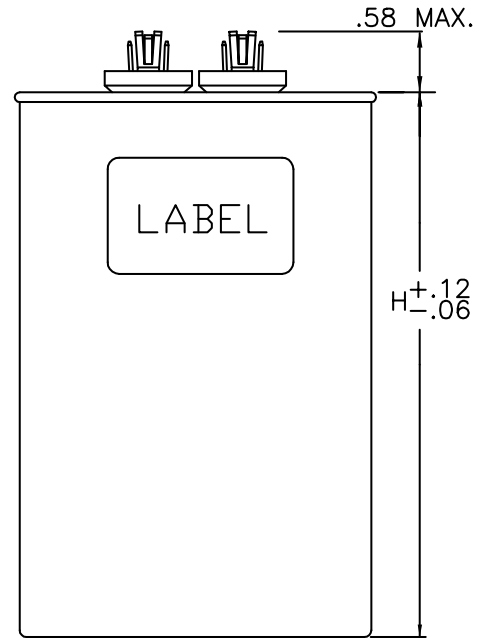
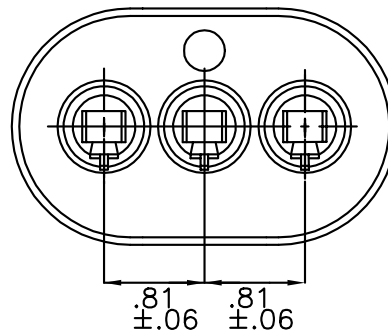

Round Oil-Filled Case Sizes

Base Size	Description	D Inches	D ₂ Inches
P	1¾" Round	1.75	1.87
S	2" Round	2.00	2.12
T	2½" Round	2.50	2.62

Round Single Cover Configuration

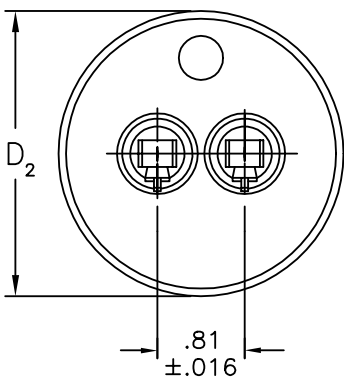

Round Dual Cover Configuration

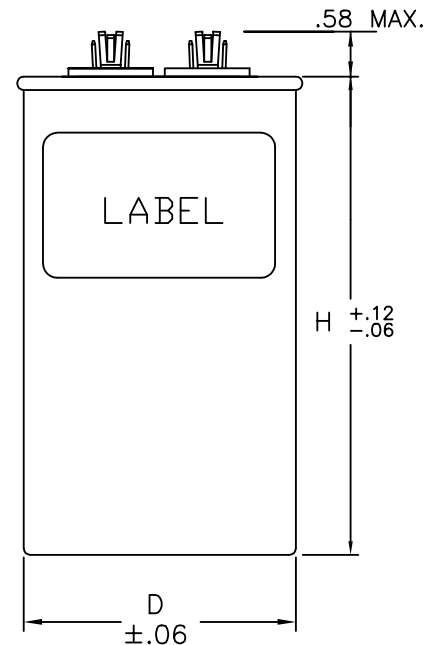
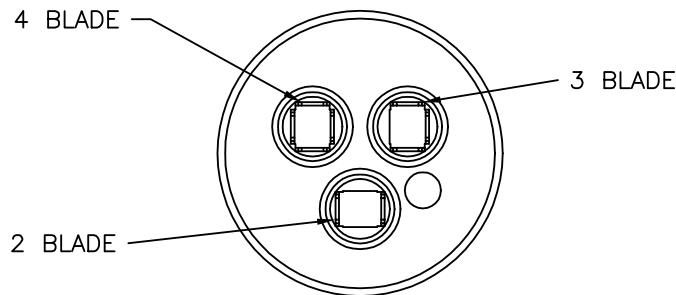

**CORNELL
DUBILIER**

1605 E. Rodney French Blvd. Tel: 508-996-8561
New Bedford, MA 02745 Fax: 508-996-3830

sales1@cde.com
www.CDE.com

ENERGIZING IDEAS

Lighting Capacitors

FILM CAPACITORS FOR HIGH INTENSITY DISCHARGE (HID) AND SIGN BALLAST LIGHTING

Dry Plastic Case Sizes

Base Diameter Size Inches (mm)

Quick Connect

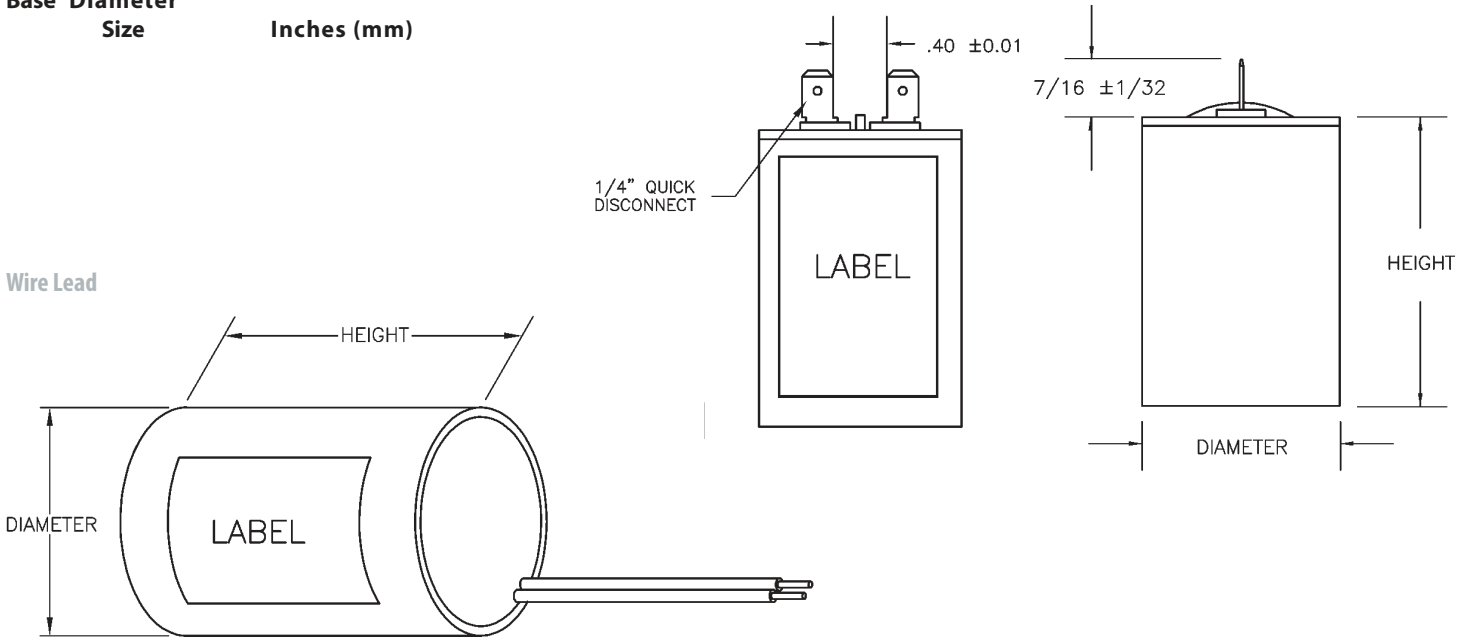

Part Numbering System

CDE's part numbering system is a descriptive part number made of several different components such as can size, voltage rating, etc. The descriptors are explained below using Z73S4026MN as a representative part number:

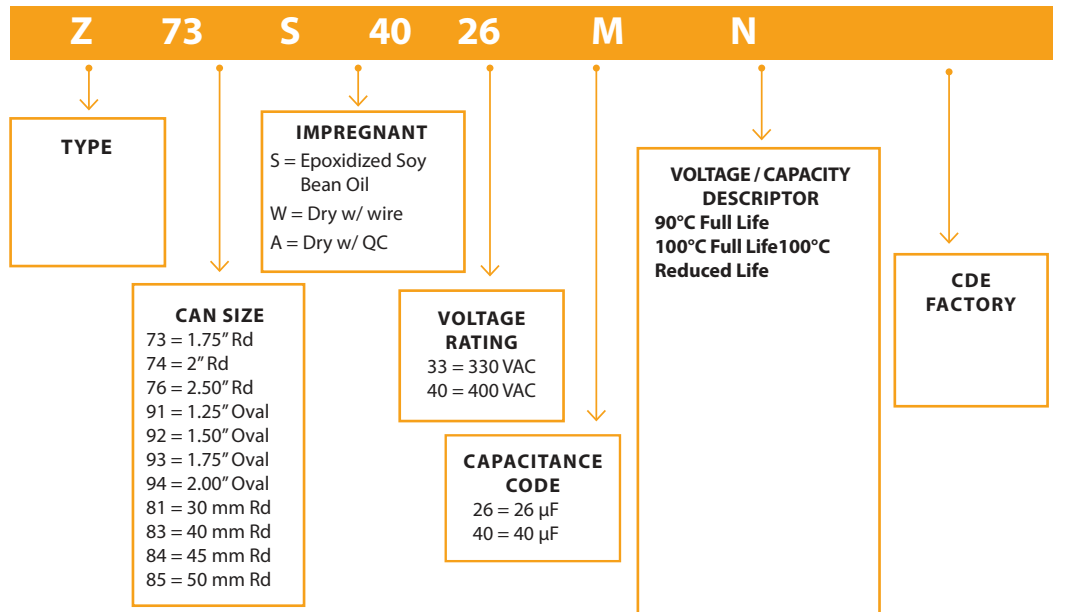

**CORNELL
DUBILIER**

1605 E. Rodney French Blvd. Tel: 508-996-8561
New Bedford, MA 02745 Fax: 508-996-3830

sales1@cde.com
www.CDE.com

Lighting Capacitors

FILM CAPACITORS FOR HIGH INTENSITY DISCHARGE (HID) AND SIGN BALLAST LIGHTING

Oil-Filled, Oval Metal Case

Rated for 60,000 hours

CAP (µF)	CDE P/N	BASE SIZE	CAN HEIGHT Inches (mm)
240 VAC, 90°C Case Temperature			
35	Z92S2435MN	B	3.75 (95.3)
40	Z92S2440MN	B	3.75 (95.3)
45	Z92S2445MN	B	3.75 (95.3)
52	Z92S2452MN	B	3.75 (95.3)
55	Z92S2455MN	B	3.75 (95.3)

300 VAC, 90°C Case Temperature

5	Z91S3005MN	A	2.19 (55.6)
6	Z91S3006MN	A	2.19 (55.6)
12	Z91S3012MN	A	2.88 (73.2)
14	Z92S3014MN	B	2.75 (69.9)
28	Z93S3028MN	C	3.13 (79.5)
40	Z93S3040MN	C	3.25 (82.6)
55	Z93S3055MN	C	3.88 (98.6)
64	Z93S3064MN	C	4.25 (108)

330 VAC, 90°C Case Temperature

7	Z91S3307MN	A	2.19 (55.6)
8	Z91S3308MN	A	2.19 (55.6)
10	Z91S3310MN	A	2.69 (68.3)
12	Z91S3312MN	A	2.88 (73.2)
14	Z91S3314MN	A	2.88 (73.2)
16	Z91S3316MN	A	3.75 (95.3)
17.5	Z92S3317NN	B	3.13 (79.5)
24	Z93S3324MN	C	2.75 (69.9)
26	Z93S3326MN	C	3.13 (79.5)
29	Z93S3329MN	C	3.13 (79.5)
30	Z93S3330MN	C	3.13 (79.5)
34	Z93S3334MN	C	3.13 (79.5)
35	Z93S3335MN	C	3.13 (79.5)
48	Z93S3348MN	C	3.88 (98.6)

CAP (µF)	CDE P/N	BASE SIZE	CAN HEIGHT Inches (mm)
400 VAC, 90°C Case Temperature			
10	Z92S4010MN	B	2.75 (69.9)
15	Z93S4015MN	C	2.75 (69.9)
21	Z93S4021MN	C	3.13 (79.5)
22.5	Z93S4022NN	C	3.13 (79.5)
24	Z93S4024MN	C	3.13 (79.5)

480 VAC, 90°C Case Temperature

3	Z91S4803MN	A	2.25 (57.2)
4	Z91S4804MN	A	2.69 (68.3)
5	Z91S4805MN	A	2.88 (73.2)
6	Z92S4806MN	B	2.75 (69.9)
10	Z92S4810MN	B	2.75 (69.9)
12	Z93S4812MN	C	3.13 (79.5)
15	Z92S4815MN	B	3.75 (95.3)
20	Z93S4820MN	C	3.75 (95.3)
21	Z93S4821MN	C	3.75 (95.3)
22	Z93S4822MN	C	3.88 (98.6)
24	Z93S4824PN	C	3.88 (98.6)
26	Z93S4826MN	C	3.88 (98.6)
28	Z93S4828PN	C	3.88 (98.6)

525 VAC, 90°C Case Temperature

16	Z93S5216NN	C	3.13 (79.5)
24	Z93S5224NN	C	4.25 (108.0)
26	Z93S5226NN	C	4.25 (108.0)
26	Z94S5226NN	D	2.88 (73.2)
32	Z93S5232NN	C	4.75 (120.7)
32	Z94S5232NN	D	3.75 (95.3)

CAP (µF)	CDE P/N	BASE SIZE	CAN HEIGHT Inches (mm)	VAC
----------	---------	-----------	------------------------	-----

400-525 VAC, 100°C Case Temperature

24	Z94S4024BN	D	3.25 (82.6)	400
24	Z94S4824BN	D	3.75 (95.3)	480
21	Z94S5221JN	D	3.75 (95.3)	525
26	Z94S5226JN	D	3.75 (95.3)	525

Lighting Capacitors

FILM CAPACITORS FOR HIGH INTENSITY DISCHARGE (HID) AND SIGN BALLAST LIGHTING

Oil-Filled, Round Metal Case

Rated for 60,000 hours

CAP (μF)	CDE P/N	BASE SIZE	CAN HEIGHT Inches (mm)
----------	---------	-----------	---------------------------

300 VAC, 90°C Case Temperature

8	Z73S3008MN	P	2.17 (55.1)
14	Z73S3014MN	P	2.38 (60.5)
22.5	Z73S3022NN	P	2.88 (73.2)

330 VAC, 90°C Case Temperature

5	Z73S3305MN	P	2.25 (57.2)
7	Z73S3307MN	P	2.88 (73.2)
12	Z73S3312MN	P	2.38 (60.5)
14	Z73S3314MN	P	2.88 (73.2)
28	Z73S3328MN	P	3.15 (80.0)

400 VAC, 90°C Case Temperature VAC

10	Z73S4010MN	P	2.38 (60.5)
15	Z73S4015MN	P	2.88 (73.2)
22.5	Z73S4022NN	P	3.75 (95.3)
24	Z73S4024MN	P	3.75 (95.3)

480 VAC, 90°C Case Temperature

10	Z73S4810MN	P	2.88 (73.2)
24	Z74S4824MN	S	3.25 (82.6)
24	Z76S4824MN	T	3.15 (80.0)

525 VAC, 90°C Case Temperature

26	Z74S5226NN	S	4.75 (120.7)
32	Z74S5232NN	S	4.92 (125.0)
32	Z76S5232NN	T	3.55 (90.2)

CAP (μF)	CDE P/N	BASE SIZE	CAN HEIGHT Inches (mm)	VAC
----------	---------	-----------	---------------------------	-----

400-480 VAC, 100°C Case Temperature

10	Z73S4010BN	P	2.38 (60.5)	400
15	Z73S4015BN	P	3.25 (82.6)	400
24	Z74S4024BN	S	3.75 (95.3)	400
24	Z74S4824BN	S	4.25 (108.0)	480



**CORNELL
DUBILIER**

1605 E. Rodney French Blvd. Tel: 508-996-8561
New Bedford, MA 02745 Fax: 508-996-3830

sales1@cde.com
www.CDE.com

About CDE

CDE is a leading provider of film capacitors for industrial, medical and specialized applications serving original equipment manufacturers (OEM) and distributors. The company has world-class design, manufacturing and testing facilities in New Bedford, Massachusetts and global manufacturing facilities in China and India to enable quick turn-around for shipping and delivery worldwide.

CDE capacitors are among the world's most reliable components. Our extensive custom design and development capabilities coupled with broad, standardized product offerings allow us to provide intelligent capacitor solutions that meet or exceed our customers' application requirements.

Our aim is to be the best and most sought after provider of capacitor solutions for specialty markets.



ENERGIZING IDEAS

**CORNELL
DUBILIER**

1605 E. Rodney French Blvd. Tel: 508-996-8561
New Bedford, MA 02745 Fax: 508-996-3830

sales1@cde.com
www.CDE.com