

ICS08 IO-Link 3-wire DC



Miniaturized proximity inductive sensors with IO-Link communication



Description

ICS08 series represents the optimal solution for industrial automation equipment in applications where space is limited, but long switching distance is needed, including tool-selection and textile machines. The advanced electronics is encapsulated in a robust stainless steel housing. The availability of the M8-plug and 2m-PVC cable connection in short or long housing construction allows flexible mounting.

On-board IO-Link communication opens up many possibilities, such as easy configuration and set-up of the devices and advanced parameter setting.

Benefits

- **A complete family.** Available in M8 male thread robust stainless steel housings with an operating distance of 2 to 4 mm.
- **Easy to install.** Both flush and non-flush construction are available. The user can choose between short and long body housings in 2 m PVC cable or M8-disconnect plug versions.
- **High precision.** The onboard advanced microcontroller ensures better stability with respect to environmental influences, with highly repeatable measurements between -25 and +80°C.
- **Easy customization to specific OEM requests:** different cable lengths and materials, special labelling, customized pig-tail solutions with special cables and connectors are possible on request.

Only for IO-Link sensors

- **The output** can be operated either as a switching output or in IO-Link mode.
- **Fully configurable via IO-Link v1.1.** Electrical outputs can be configured as PNP/NPN/Push-pull, normally open or normally closed.
- **Timer functions** can be set, such as switch-on and switch-off delay
- **Adjustable sensing distance and hysteresis:** sensing distance can be set to 50% or 100% of the maximum sensing distance
- **Temperature monitoring:** over or under-run temperature alarms can be set



Applications

- Non contact detection of metal objects in general position-sensing and presence-sensing in industrial applications
- Particularly suitable for rotational speed monitoring thanks to the high operating frequency

Main functions

- Integrated diagnostic function with flashing LED in the event of a short circuit or overload

IO-Link sensors

- The devices can be operated in IO-Link mode once connected to an IO-Link master, or in standard I/O mode.
- In IO-Link mode the switching signals of the sensor are made available in the process data via the IO-Link interface.
- Several sensor functions can be set via the IO-Link interface:
 - ▶ Adjustable switching distance: 50% or 100% of the maximum switching distance.
 - ▶ Adjustable hysteresis: standard or increased value.
 - ▶ Divider function: the sensor gives a signal after a specified number of actuation pulses has been reached.
 - ▶ Switch-on delay: the switching pulse is generated after the sensor actuation.
 - ▶ Switch-off delay: the generation of the switch signal is delayed by the set time after sensor actuation.
 - ▶ Temperature error: temperature is out of specifications.
 - ▶ Temperature over-run and under-run: temperature is out of the limits defined by the user.

References

Order code

 I C S 08

Enter the code option instead of

Code	Option	Description
I	-	Inductive sensor
C	-	Cylindrical housing with threaded barrel
S	-	Stainless steel housing
08	-	M8 housing
<input type="checkbox"/>	S30	Short housing with thread barrel of 30 mm
<input type="checkbox"/>	L45	Long housing with thread length of 45 mm
<input type="checkbox"/>	F	Flush
<input type="checkbox"/>	N	Non-flush
<input type="checkbox"/>	20	Sensing distance 2mm
<input type="checkbox"/>	40	Sensing distance 4mm
<input type="checkbox"/>	M5	M8 plug
<input type="checkbox"/>	A2	2 m PVC cable
<input type="checkbox"/>	NO	NPN – normally open output
<input type="checkbox"/>	NC	NPN – normally closed output
<input type="checkbox"/>	PO	PNP – normally open output
<input type="checkbox"/>	PC	PNP – normally closed output
<input type="checkbox"/>	IO	IO-Link programmable version

Additional characters can be used for customized versions.

 Selection guide

M8 extended range, short housing

Con- nec- tion	Rated operating distance Sn	Dete- ction princi- ple	Ordering no. NPN, Normally open	Ordering no. PNP, Normally open	Ordering no. NPN, Normally closed	Ordering no. PNP, Normally closed
Cable	2 mm	Flush	ICS08S30F20A2NO	ICS08S30F20A2PO	ICS08S30F20A2NC	ICS08S30F20A2PC
Plug			ICS08S30F20M5NO	ICS08S30F20M5PO	ICS08S30F20M5NC	ICS08S30F20M5PC
Cable	4 mm	Non- flush	ICS08S30N40A2NO	ICS08S30N40A2PO	ICS08S30N40A2NC	ICS08S30N40A2PC
Plug			ICS08S30N40M5NO	ICS08S30N40M5PO	ICS08S30N40M5NC	ICS08S30N40M5PC

M8 extended range, long housing

Con- nec- tion	Rated operating distance Sn	Dete- ction princi- ple	Ordering no. NPN, Normally open	Ordering no. PNP, Normally open	Ordering no. NPN, Normally closed	Ordering no. PNP, Normally closed
Cable	2 mm	Flush	ICS08L45F20A2NO	ICS08L45F20A2PO	ICS08L45F20A2NC	ICS08L45F20A2PC
Plug			ICS08L45F20M5NO	ICS08L45F20M5PO	ICS08L45F20M5NC	ICS08L45F20M5PC
Cable	4 mm	Non- flush	ICS08L45N40A2NO	ICS08L45N40A2PO	ICS08L45N40A2NC	ICS08L45N40A2PC
Plug			ICS08L45N40M5NO	ICS08L45N40M5PO	ICS08L45N40M5NC	ICS08L45N40M5PC

IO-Link types

Con- nec- tion	Body style	Dete- ction princi- ple	Rated operating distance Sn	Output type	Ordering no.
Cable	Short	Flush	Configurable: 1 or 2mm Factory setting: 2mm	Configurable: NPN/PNP/ push-pull NO/NC Factory setting: PNP, NO	ICS08S30F20A2IO
Plug			ICS08S30F20M5IO		
Cable		Non- flush	Configurable: 2 or 4mm Factory setting: 4mm		ICS08S30N40A2IO
Plug			ICS08S30N40M5IO		
Cable	Long	Flush	Configurable: 1 or 2mm Factory setting: 2mm		ICS08L45F20A2IO
Plug			ICS08L45F20M5IO		
Cable		Non- flush	Configurable: 2 or 4mm Factory setting: 4mm		ICS08L45N40A2IO
Plug			ICS08L45N40M5IO		

Structure

ICS08

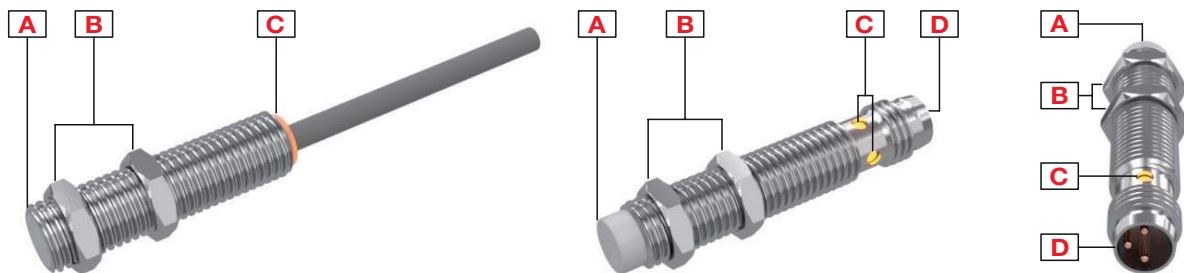

Element	Component	Function
A	Sensing face	Flush or non-flush
B	2 nuts	For sensor mounting
C	LED	Yellow LED: Output flashing: short circuit or overload indication
D	M8, 3 pin, male connector	For plug versions only

Sensing

Detection

Rated operating distance S_n	2 mm flush or 4 mm non-flush
Reference target	The operating distance is measured according to IEC 60947-5-2, using a standard target moving axially. This target is square shape 1 mm thickness, made of steel e.g. type Fe 360 as defined in ISO 630 and it shall be of the rolled finish. The length of the side of the square is equal to – the diameter of the circle inscribed on the active surface of the sensing face, or – three times the rated operating distance S_n whichever is greater
Assured operating sensing distance (S_a)	$0 \leq S_a \leq 0.81 \times S_n$ (e.g. with S_n of 2 mm, S_a is 0 ... 1.62 mm)
Effective operating distance (S_r)	$0.9 \times S_n \leq S_r \leq 1.1 \times S_n$
Usable operating distance (S_u)	$0.9 \times S_r \leq S_u \leq 1.1 \times S_r$
Temperature drift	$\leq \pm 10\%$
Hysteresis (H)	1...20%

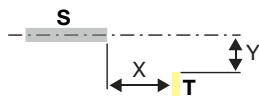

S: sensor
T: target

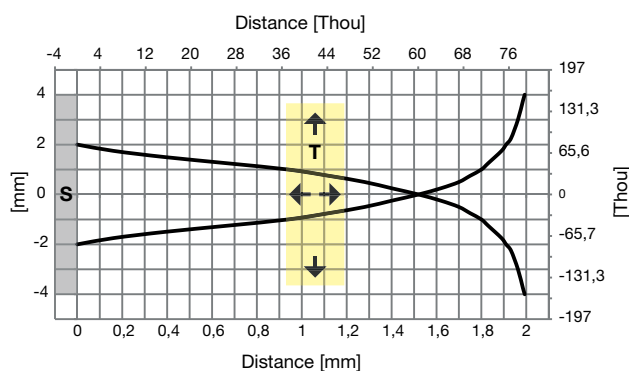

Fig. 1 Flush

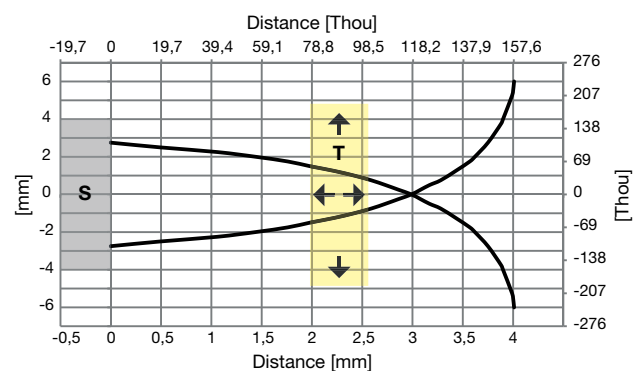

Fig. 2 Non-flush

Sensors with IO-Link communication

Rated operating distance S_n	Programmable via IO-Link: 50% or 100% of the maximum S_n
Hysteresis (H)	Programmable via IO-Link: standard or increased

Correction factors

The specific operating distance S_n refers to defined measuring conditions. The following data have to be considered as general guidelines.

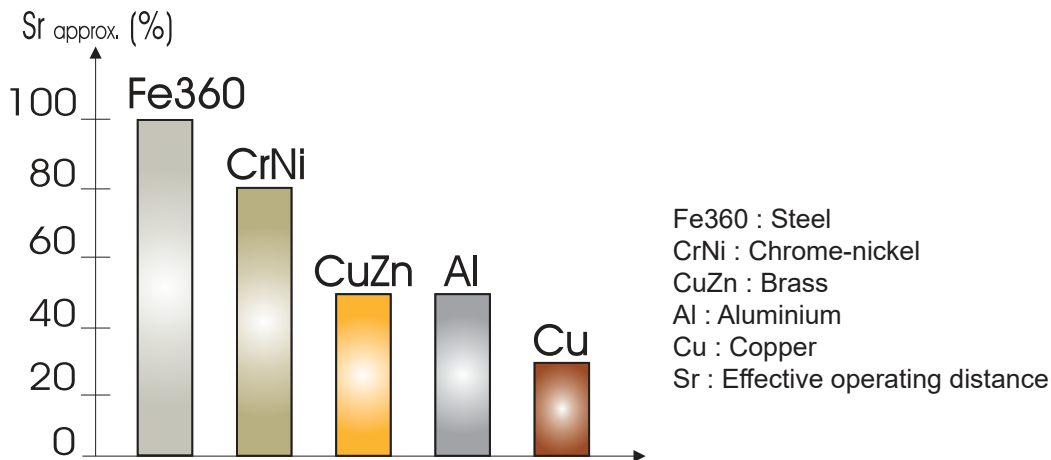

Fig. 3 The rated operating distance is reduced by the use of metals and alloys other than Fe360. The most important reduction factors for inductive proximity sensors are shown in the figure.

Accuracy

Repeat accuracy (R)	≤ 5%
---------------------	------

Features

Power Supply

Rated operational voltage (U_b)	10 to 30 VDC (ripple included)
Ripple (U_{rpp})	≤ 10%
No load supply current (I_o)	≤ 17 mA
Power ON delay (t_o)	≤ 50 ms

Outputs

	Standard sensors	IO-Link sensors
Output functions	NPN or PNP by sensor type	Configurable via IO-Link: PNP, NPN or push-pull Factory setting: PNP
Output configuration	N.O. and N.C. by sensor type	Configurable via IO-Link: N.O. or N.C. Factory setting: N.O.
Output current (I_o)	≤ 100 mA	
OFF-state current (I_o) (only for PNP or NPN output)	≤ 100 μ A	
Voltage drop (U_d)	Max. 1.2 VDC @ 100 mA	
Protection	Short-circuit, reverse polarity and transients	
Voltage transient	1 kV/0.5 J	



Response times

Operating frequency (f)	≤ 2 KHz
-------------------------	---------

Indication

Standard IO mode:

Yellow LED	Output	Description
OFF	OFF	N.O. output, target not present N.C. output, target present
ON	ON	N.O. output, target present N.C. output, target not present
Blinking	f: 2Hz	Short-circuit or overload
	f: 1Hz	Temperature alarm (if enabled)





IO-Link mode:

- LED is ON for 0.75 s and OFF for 0.075 s
- Possibility to disable the LED

Environmental

Ambient temperature	Operating: -25° to +80°C (-13° to +176°F)	
	Storage: -30° to +80°C (-22° to +176°F)	
Ambient humidity	Operating: 35% to 95%	
	Storage: 35% to 95%	
Vibration	10 to 55 Hz, amplitude 1.0 mm; sweep cycle 5 min; in X, Y and Z direction	IEC 60068-2-6
Shock	30 G /11 ms. 10 shocks in X, Y and Z direction	IEC 60068-2-27
Degree of protection	IP67	IEC 60529; EN 60947-1

Compatibility and conformity

EMC protection	IEC 61000-4-2 Electrostatic discharge	8 kV air discharge 4 kV contact discharge
	IEC 61000-4-3 Radiated radiofrequency	3 V/m
	IEC 61000-4-4 Burst immunity	2 kV
	IEC 61000-4-6 Conducted radio frequency	3 V
	IEC 61000-4-8 Power frequency magnetic fields	30 A/m
MTTF _d	4513 years @ 50°C (122°F)	
Approvals	    IO-Link	
	CCC is not required for products rated ≤ 36 V	

Mechanical data

Weight (including 2 nuts and the packaging) max.	Cable version: short, flush: 44.8g; short, non-flush: 44.9g; long, flush: 47g; long, non-flush: 47.1g; Plug version: short, flush: 16g; short, non-flush: 16.1g; long, flush: 18.4g; long, non-flush: 18.5g.
Mounting	Flush mountable or non-flush mountable
Material	Housing: stainless steel AISI304 Front cap: Grey thermoplastic polyester
Max tightening torque	7 Nm

Electrical connection

Cable	2m, 3 x 0.14 mm ² , Ø3.2 mm, PVC, grey, oil proof
Plug	M8 x 1 quick disconnect, 3 pin, male connector

IO-Link version only

Communication	Via IO-Link V1.1 or via standard I/O
----------------------	--------------------------------------

Connection Diagrams

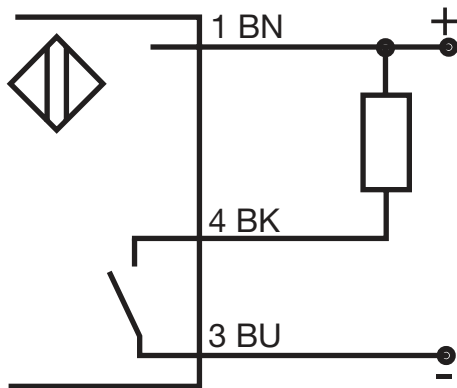

Fig. 4 NPN - Normally open

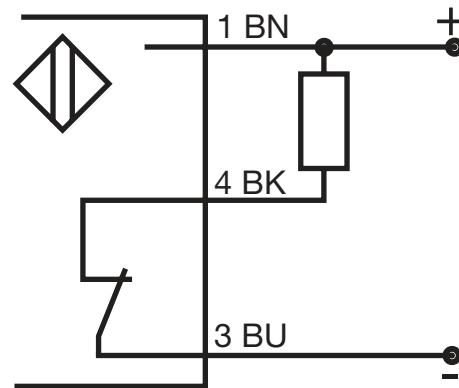

Fig. 5 NPN - Normally closed

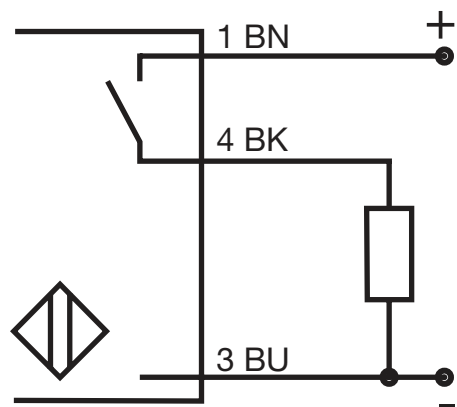

Fig. 6 PNP - Normally open

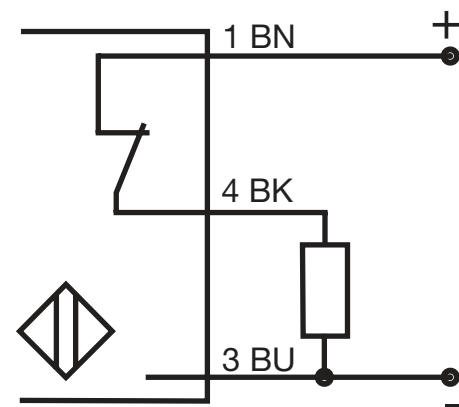

Fig. 7 PNP - Normally closed

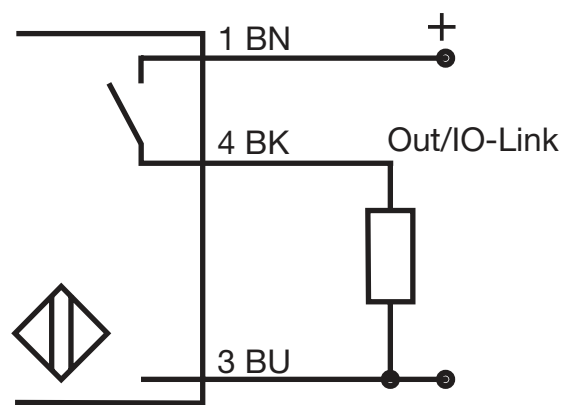

Fig. 8 IO-Link

Colour code		
BN: brown	BK: black	BU: blue

Dimensions [mm]

ICS08 [mm]

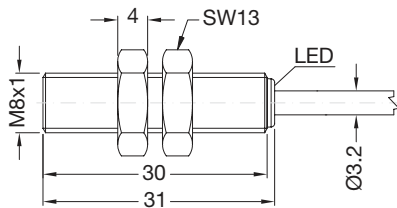

Fig. 9 Short body, flush version, cable

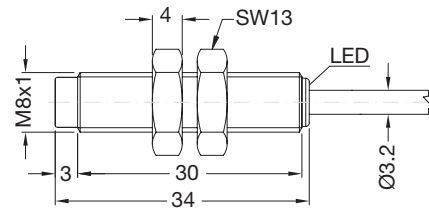

Fig. 10 Short body, non-flush version, cable

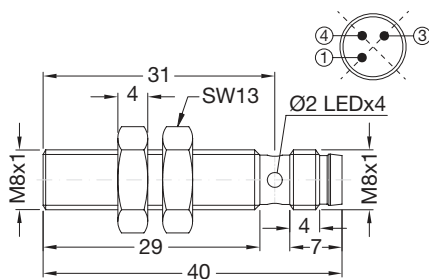

Fig. 11 Short body, flush version, plug

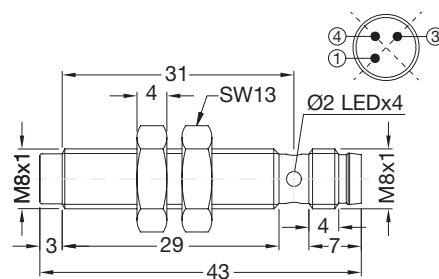

Fig. 12 Short body, non-flush version, plug

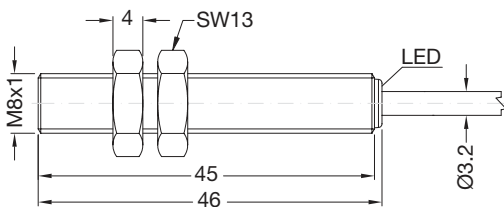

Fig. 13 Long body, flush version, cable

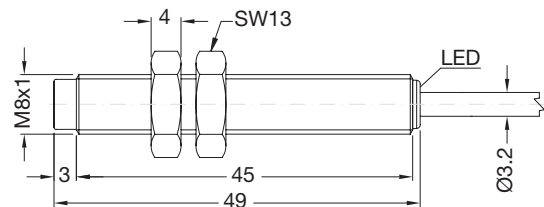

Fig. 14 Long body, non-flush version, cable

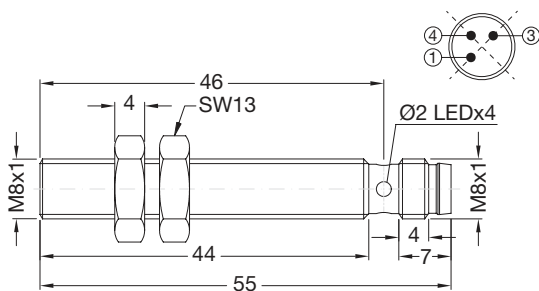

Fig. 15 Long body, flush version, plug

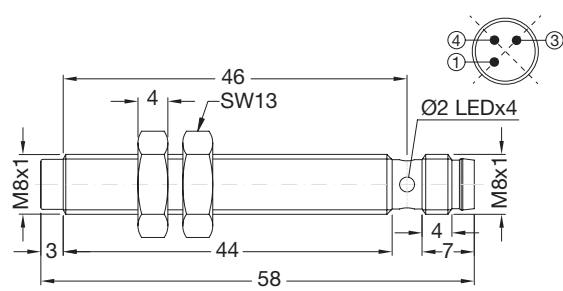

Fig. 16 Long body, non-flush version, plug

Installation

M8 flush

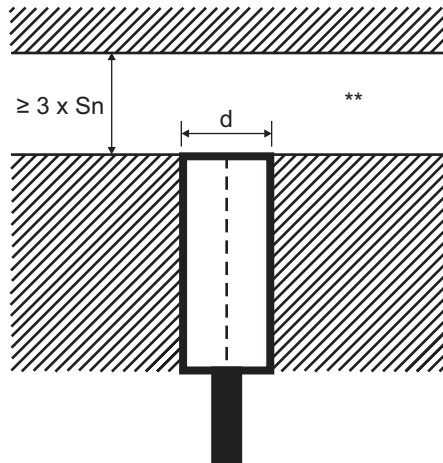

Fig. 17 Flush sensor, when installed in damping material

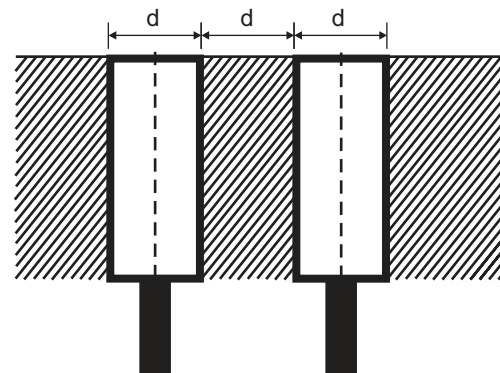

Fig. 18 Flush sensors, when installed together in damping material

M8 non-flush

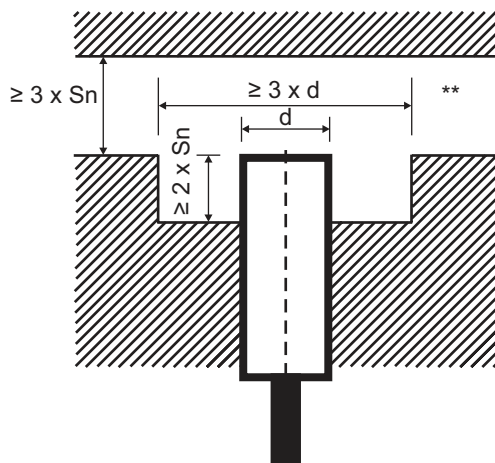

Fig. 19 Non-flush sensor, when installed in damping material

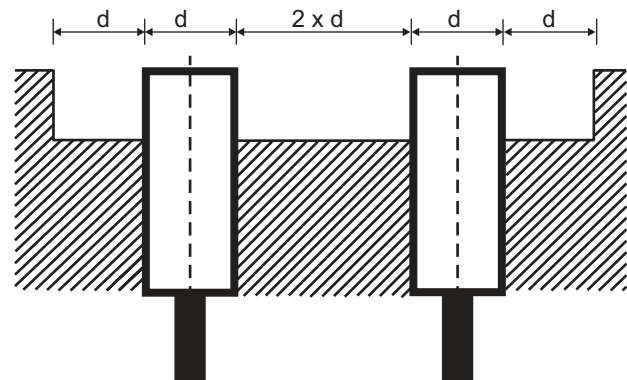

Fig. 20 Non-flush sensors, when installed together in damping material

Sensors installed opposite each other

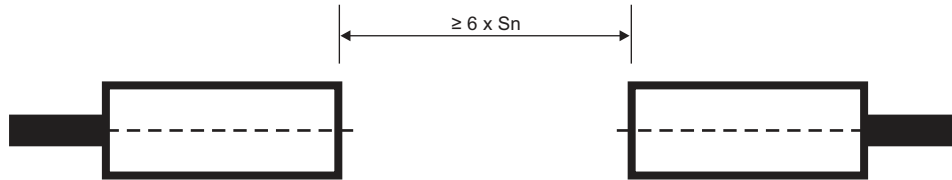

Fig. 21 For sensors installed opposite each other, a minimum space of $6 \times S_n$ (the nominal sensing distance) must be observed

** Free zone or non-damping material

S_n : nominal sensing distance

d: sensor diameter: 8 mm

Delivery contents and compatible components



Delivery contents

- Inductive proximity switch
- 2 fixing nuts
- 2 lock washers
- Packaging: plastic bag

CARLO GAVAZZI compatible components

- Mounting bracket AMB8... to be purchased separately
- Connector type: CONB53... series to be purchased separately

Further reading

Information	Where to find it	QR
IO-Link manual	http://www.productselection.net/MANUALS/UK/IOL_IM.pdf	
Mounting brackets	http://www.productselection.net/Pdf/UK/AMB8_30.pdf	
Connectors	http://www.productselection.net/Pdf/UK/CONB5.pdf	

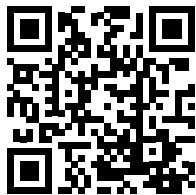

COPYRIGHT ©2018
Content subject to change. Download the PDF: www.productselection.net