

POWER MANAGEMENT

Description

The EZ1588 is a high performance positive voltage regulator designed for use in applications requiring low dropout performance at 2A. Additionally, the EZ1588 series provides excellent regulation over variations in line, load and temperature.

Outstanding features include low dropout performance at rated current, fast transient response, internal current limiting and thermal shutdown protection of the output device.

The EZ1588 series are three terminal regulators with fixed and adjustable voltage options available in popular packages.

Features

- ◆ Low dropout performance: 1.3V max.
- ◆ Full current rating over line and temperature
- ◆ Fast transient response
- ◆ ±2% total output regulation over line, load and temperature
- ◆ Adjust pin current max. 90µA over temperature
- ◆ Fixed/adjustable output voltage
- ◆ Line regulation typically 0.005%
- ◆ Load regulation typically 0.05%
- ◆ TO-220 or TO-263 packages

Applications

- ◆ Memory supplies
- ◆ Graphics core supplies
- ◆ 2.5V to 3.6V microprocessor supplies
- ◆ Low voltage logic supplies
- ◆ Battery-powered circuitry
- ◆ Post regulator for switching supply

Typical Application Circuit

Fixed Voltage Regulator

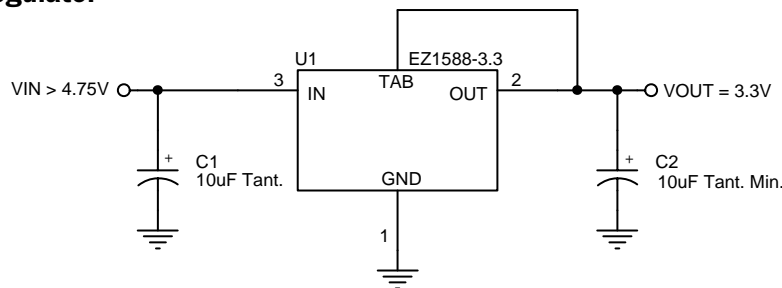

Adjustable Voltage Regulator

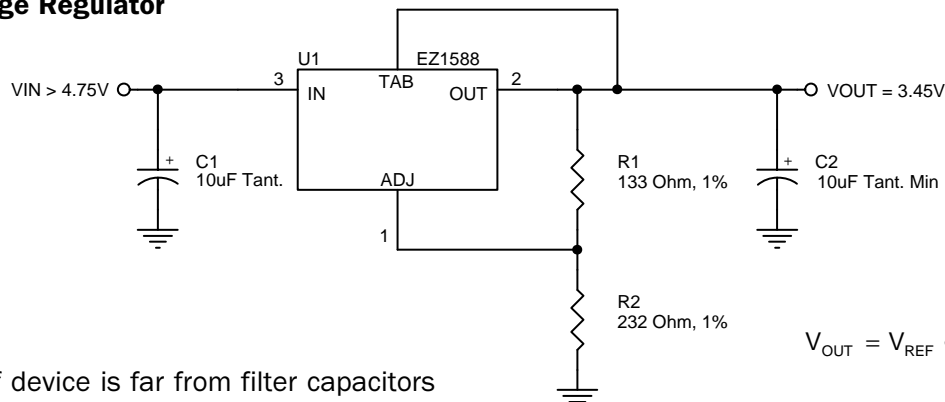

Notes:

- (1) C1 needed if device is far from filter capacitors
- (2) C2 minimum value required for stability

$$V_{OUT} = V_{REF} \cdot \left(1 + \frac{R2}{R1}\right) + I_{ADJ} \cdot R2$$

POWER MANAGEMENT
Absolute Maximum Ratings

Parameter	Symbol	Maximum	Units
Input Supply Voltage	V_{IN}	7	V
Power Dissipation	P_D	Internally Limited	W
Thermal Resistance Junction to Case TO-220 TO-263	θ_{JC}	3 3	$^{\circ}CW$
Thermal Resistance Junction to Ambient TO-220 TO-263	θ_{JA}	50 60	$^{\circ}CW$
Operating Junction Temperature Range	T_J	0 to 125	$^{\circ}C$
Storage Temperature Range	T_{STG}	-65 to 150	$^{\circ}C$
Lead Temperature (Soldering) 10 Sec.	T_{LEAD}	300	$^{\circ}C$
ESD Rating (Human Body Model)	V_{ESD}	2	kV

Electrical Characteristics

Unless otherwise specified: Adj. $V_{IN} = 2.75$ to $7.0V$ and Adj. $I_O = 10mA$ to $2.0A$; Fixed $V_{IN} = 4.75$ to $7.0V$ and Fixed $I_O = 0mA$ to $2.0A$

Parameter	Symbol	V_{IN}	I_O	$T_J^{(4)}$	Min	Typ	Max	Units	
Output Voltage ⁽¹⁾	V_O	5V	0mA	25 $^{\circ}C$	$0.99V_O$	V_O	$1.01V_O$	V	
Fixed Voltage Version				O.T.	$0.98V_O$	V_O	$1.02V_O$		
Reference Voltage ⁽¹⁾	V_{REF}	5V	10mA	25 $^{\circ}C$	1.238	1.250	1.262	V	
Adj. Voltage Version				O.T.	1.225	1.250	1.275		
Line Regulation ⁽¹⁾	$REG_{(LINE)}$			25 $^{\circ}C$		0.005	0.2	%	
Fixed Voltage Version				0mA	O.T.		0.035		0.2
Adj. Voltage Version				10mA					
Load Regulation ⁽¹⁾	$REG_{(LOAD)}$	5V		25 $^{\circ}C$		0.05	0.3	%	
				O.T.			0.2		0.4
Dropout Voltage ⁽²⁾	V_D			25 $^{\circ}C$		1		V	
				O.T.			1.1		1.3
Current Limit	I_{CL}			O.T.	2.0	2.5		A	
Quiescent Current Fixed Voltage Version	I_Q	5V		O.T.		10	13	mA	
Temperature Coefficient	T_C			O.T.		0.004	0.02	$\%/^{\circ}C$	

POWER MANAGEMENT
Electrical Characteristics (Cont.)

Unless otherwise specified: Adj. $V_{IN} = 2.75$ to $7.0V$ and Adj. $I_O = 10mA$ to $2.0A$; Fixed $V_{IN} = 4.75$ to $7.0V$ and Fixed $I_O = 0mA$ to $2.0A$

Parameter	Symbol	V_{IN}	I_O	$T_J^{(4)}$	Min	Typ	Max	Units
Adjust Pin Current	I_{ADJ}			25°C		55		μA
				O.T.			90	
Adjust Pin Current Change	ΔI_{ADJ}			O.T.		0.2	5	μA
Temperature Stability	T_S	5V	0.5A	O.T.		0.5		%
Minimum Load Current Adj Voltage Version	I_O	5V		O.T.		5	10	mA
RMS Output Noise ⁽³⁾	V_N			25°C		0.003		% V_O
Ripple Rejection Ratio ⁽⁴⁾	R_A	5V	2.0A	O.T.	60	72		dB

Notes:

- (1) Low duty cycle pulse testing with Kelvin connections required.
- (2) $\Delta V_{OUT}, \Delta V_{REF} = 1\%$
- (3) Bandwidth of 10 Hz to 10 kHz.
- (4) 120 Hz input ripple, (C_{ADJ} for ADJ = 25 μF).
- (5) Over Temp. (O.T.) = over specified operating junction temperature range.

POWER MANAGEMENT

Pin Configuration

PIN	FUNCTION
1	ADJ/GND
2	OUTPUT
3	INPUT

TAB IS OUTPUT

Ordering Information

Device ⁽¹⁾	Package
EZ1588CT-X.X	TO-220
EZ1588CM-X.X.TR	TO-263 ⁽²⁾

Notes:

- (1) Where X.X denotes voltage options. Available voltages are: 3.3V. Leave blank for adjustable version (1.3 to 5.7V). Contact factory for additional voltage options.
- (2) Only available in tape and reel packaging. A reel contains 800 devices.

Block Diagram

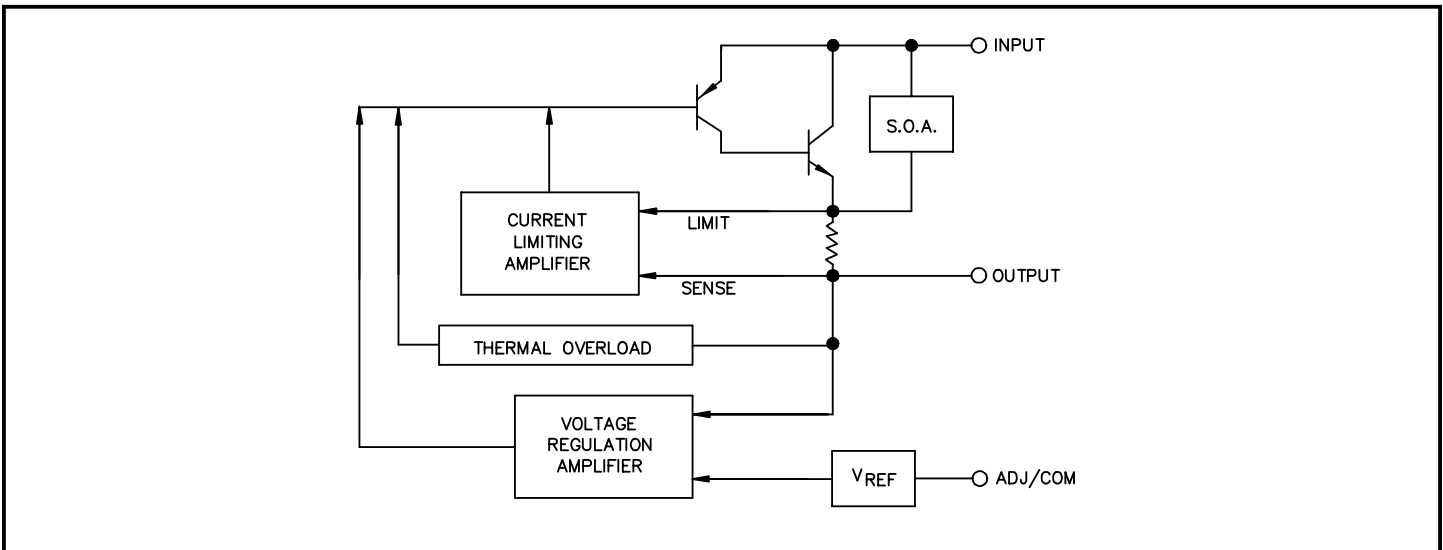

Outline Drawing - TO-220

DIM ^N	DIMENSIONS				NOTE
	INCHES		MM		
A	.560	.650	14.23	16.51	
B	.380	.420	9.66	10.66	
C	.140	.190	3.56	4.82	
D	.020	.045	0.51	1.14	
F	.139	.161	3.54	4.08	
G	.090	.110	2.29	2.79	
H	—	.250	—	6.35	
J	.012	.045	.31	1.14	
K	.500	.580	12.70	14.73	
L	.045	.070	1.15	1.77	
N	.190	.210	4.83	5.33	
Q	.100	.135	2.54	3.42	
R	.080	.115	2.04	2.92	
S	.020	.055	.51	1.39	
T	.230	.270	5.85	6.85	

JEDEC TO-220

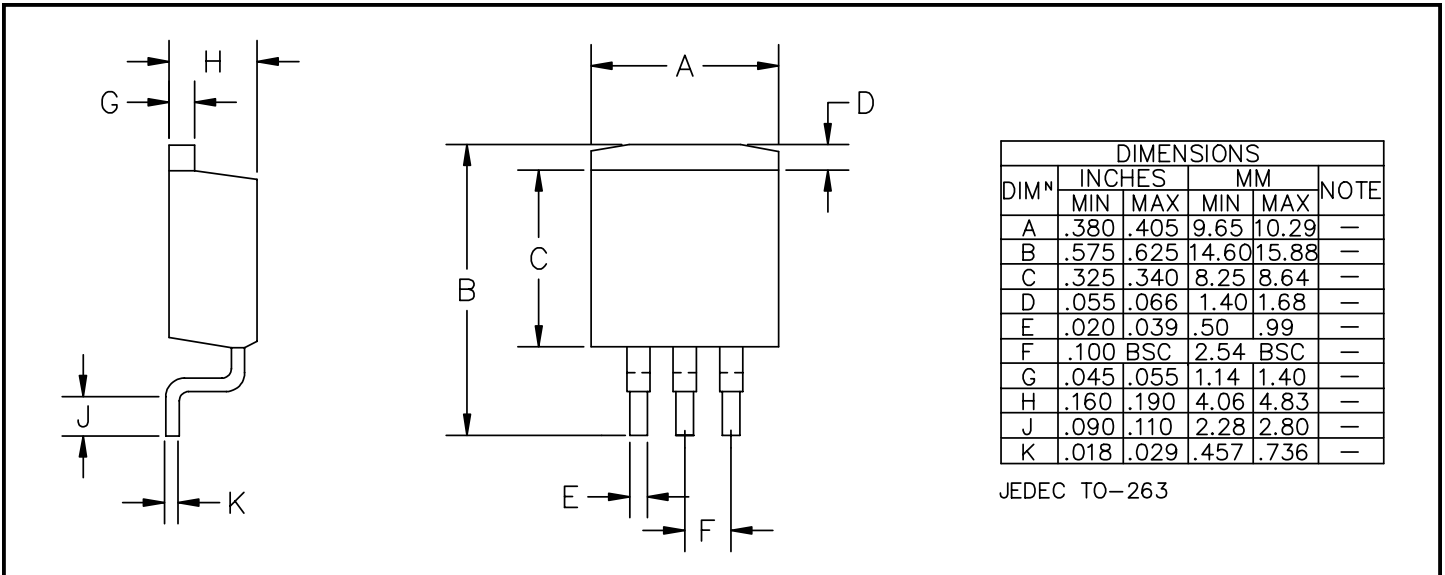
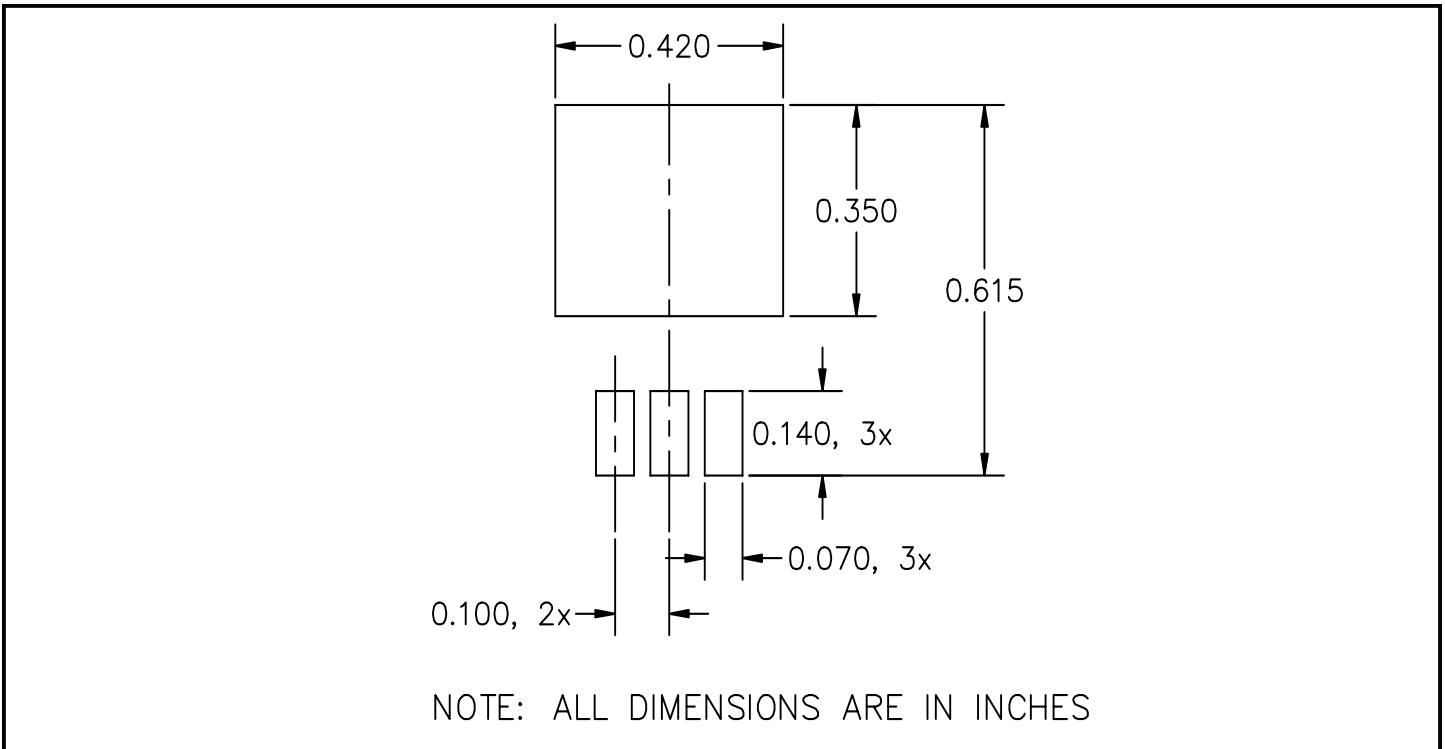
POWER MANAGEMENT
Outline Drawing - TO-263

Land Pattern - TO-263

Contact Information

Semtech Corporation
 Power Management Products Division
 652 Mitchell Rd., Newbury Park, CA 91320
 Phone: (805)498-2111 FAX (805)498-3804