

Evaluating the **ADAU1977/ADAU1978/ADAU1979**

FEATURES

For the evaluation of the **ADAU1977/ADAU1978/ADAU1979**
quad ADCs

Total harmonic distortion (THD) plus noise (N): -95 dB at
 -1 dBFS

Signal to noise ratio (SNR): 109 dB, A weighting filter

Built-in diagnostics for microphone inputs

APPLICATIONS

Automotive

GENERAL DESCRIPTION

The **EVAL-ADAU1977Z/EVAL-ADAU1978Z/EVAL-ADAU1979Z** is used for quick evaluation of the **ADAU1977/ADAU1978/ADAU1979** quad ADCs. The evaluation board can output up to four channels of digital output. The evaluation board requires a power supply of $+5$ V for the **ADAU1978** and the **ADAU1979** and a power supply of $+5$ V and ± 20 V (optional) for testing the diagnostic features of the **ADAU1977**.

EVALUATION BOARD CONNECTION DIAGRAM

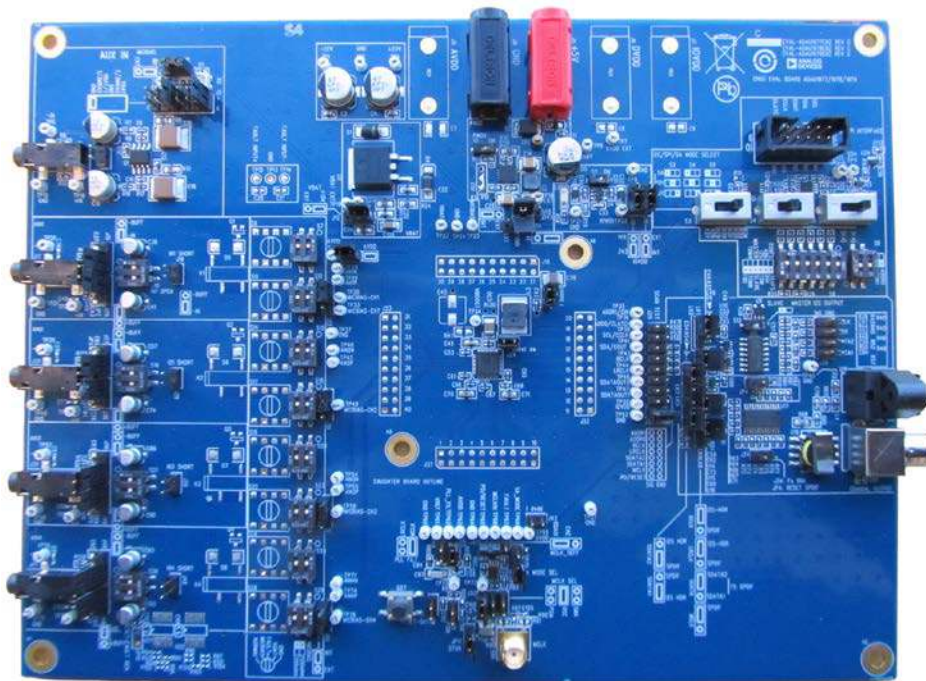

11751-001

Figure 1.

TABLE OF CONTENTS

Features	1	Evaluation Board Setup Instructions.....	6
Applications.....	1	Jumper Settings.....	6
General Description	1	USBi and Standalone GUI Setup.....	7
Evaluation Board Connection Diagram	1	ADAU1977 Power-On.....	7
Revision History	2	Standalone GUI I ² C Control.....	7
Evaluation Board Hardware	3	Microphone Diagnostics	8
Power Supply Connectors	3	Standalone GUI SPI Control	9
Input Connectors.....	3	Standalone Mode.....	9
Output Connectors	3	Evaluation Board Schematics and Artwork.....	10
I ² C/SPI Control Connector	3	Board Layout.....	16
Jumpers	3	Ordering Information.....	23
Setup of the Evaluation Board Connections	5	Bill of Materials.....	23

REVISION HISTORY

8/14—Revision 0: Initial Version

EVALUATION BOARD HARDWARE

The [EVAL-ADAU1977Z](#) board is common for the [ADAU1977](#), [ADAU1978](#), and [ADAU1979](#). The evaluation board is designed as a 4-layer printed circuit board (PCB). The top and bottom layers are for signals, whereas Layer 2 and Layer 3 are used as ground and a power plane, respectively. The PCB layout is important to achieve good audio performance. The following sections offer useful guidelines for operation of the board.

POWER SUPPLY CONNECTORS

The [EVAL-ADAU1977Z](#) board requires +5 V for the [ADAU1978](#) and [ADAU1979](#) and may need an additional ± 20 V for testing the 10 V rms inputs of the [ADAU1977](#). Connect the 5 V power supply at J5 and J4. Connect the ± 20 V power supply at either TP3 (+20 V) or TP1 (–20 V). The +5 V power supply must be capable of providing a 1 A current rating, and the ± 20 V power supply must be capable of providing at least a 100 mA current rating. When the diagnostics feature is not used, the ± 20 V supply is not required.

INPUT CONNECTORS

The [EVAL-ADAU1977Z](#) has five 3.5 mm audio jack connectors for analog inputs: J9, J17, J28, J38, and J47. The J9 connector is used for generating line level inputs capable of 10 V rms, with a common-mode level of 7 V for the [ADAU1977](#). The J17, J28, J38, and J47 connectors are used as Channel 1, Channel 2, Channel 3, and Channel 4 line level inputs to the ADC, respectively. All five inputs are differential.

OUTPUT CONNECTORS

The ADC digital output is available at J25 (unbuffered) and J26 (buffered). In addition, ADC digital output is available as a 2-channel Sony Philips digital interface format (SPDIF). J25 and J26 are used for I²S or time division multiplex (TDM), serial digital output. The U16 provides the SPDIF optical output, and J35 provides the SPDIF coaxial output.

I²C/SPI CONTROL CONNECTOR

The J8 (10-way header) can be used for I²C/SPI serial port communication for controlling the board. The supplied USB interface board can be used for setting the device. The graphic user interface (GUI) software is used along with the USB interface board.

JUMPERS

The [EVAL-ADAU1977Z](#) board provides jumpers for setting this board into various operating modes.

Table 1. Jumper Descriptions

Component No.	Mnemonic	Description
J1	MICBIAS SELECT AUX IN	This jumper allows selecting either internal or external micbias for auxiliary input.
J2	CM SELECT AUX IN	Used for setting the common mode level for auxiliary input.
J4	GND	Ground or 0 V connection for the power supply.
J5	+5V	+5 V connection for the power supply.
J8	USBi	Connector for USBi board.
J9	AUX IN	Connector for auxiliary input.
J10	IOVDD	Selects the IOVDD 1.8 V or 3.3 V.
J11	IOVDD Ext/Int	Selects the internal or external supply for IOVDD.
J12	VBAT Ext/Int	Selects the internal or external supply for VBAT.
J13	3.3 V Ext/Int	Selects the internal or external 3.3 V supply.
J14	AVDD Ext/Int	Selects the internal or external AVDD supply for the ADAU1977 .
J15/J20	Input 1 Select	Selects the input source for Channel 1.
J16	AVDD Current	This jumper is used to measure the AVDD current.
J17	CH1 Input	Connector for Channel 1 input.
J19	Input Short	This jumper is used to short the \pm Channel 1 input.
J21	Boost Current	This jumper is used to measure the boost converter current.
J22	MICBIAS-CH1	Selects the internal or external micbias for Channel 1.
J24	Boost Switch	This jumper is used to measure the boost switch current.
J25	ADC Output	Header for connection to ADC digital pins.
J26	ADC Output Buffered	Header for ADC digital output.
J27/J30	Input 2 Select	Selects the input source for Channel 2.
J28	CH2 Input	Connector for Channel 2 input.
J29	Input Short	This jumper is used to short the \pm Channel 2 input.

Component No.	Mnemonic	Description
J31	MICBIAS-CH1	Selects the internal or external micbias for Channel 2.
J33	IOVDD Current	Connector for measuring IOVDD current.
J34	128fs Mode	Selects the 96 k sample rate for the SPDIF transmitter.
J35	Coaxial Output	Connector for SPDIF coaxial output.
J36/J40	Input 3 Select	Selects the input source for Channel 3
J28	CH3 Input	Connector for Channel 3 input.
J39	Input Short	This jumper is used to short the \pm Channel 3 input.
J41	MICBIAS-CH1	Selects the internal or external micbias Channel 3.
J42	DVDD	External DVDD current measurement.
J43	MCLKIN	Selects the external master clock input to the ADAU1977 .
J44	PLL Filter	Selects the PLL filter for LRCLK mode.
J45	PLL Filter	Selects the PLL filter for MCLK mode.
J46/J49	Input 4 Select	Selects the input source for Channel 4.
J48	Input Short	This jumper is used to short the \pm Channel 4 Input.
J50	MCLKIN	Selects the source for MCLKIN between oscillator, header, and Subminiature Version A, SMA.
J51	MICBIAS-CH1	Selects the internal or external micbias Channel 4.
J52	MCLK Input	SMA connector for external master clock input.
J53	FREQ Select	Selects the switching frequency for the 3.3 V regulator.
JP1	AUX IN	Header for external auxiliary input
JP2	CH1 IN	Header for external Channel 1 input.
JP3	CH2 IN	Header for external Channel 2 input.
JP4	Reset SPDIF Tx	SPDIF Tx reset.
JP5	CH3 IN	Header for external Channel 3 input.
JP6	SA Mode	This jumper is used for standalone mode.
JP7	CH4 IN	Header for external Channel 4 input.
JP8	RESET	Header for the ADAU1977 reset.
JP9	MCLKIN	Header for master clock input.
JP10	Reserved	Reserved for internal use.
JP11	Oscillator Enable	Enables the oscillator.

SETUP OF THE EVALUATION BOARD CONNECTIONS

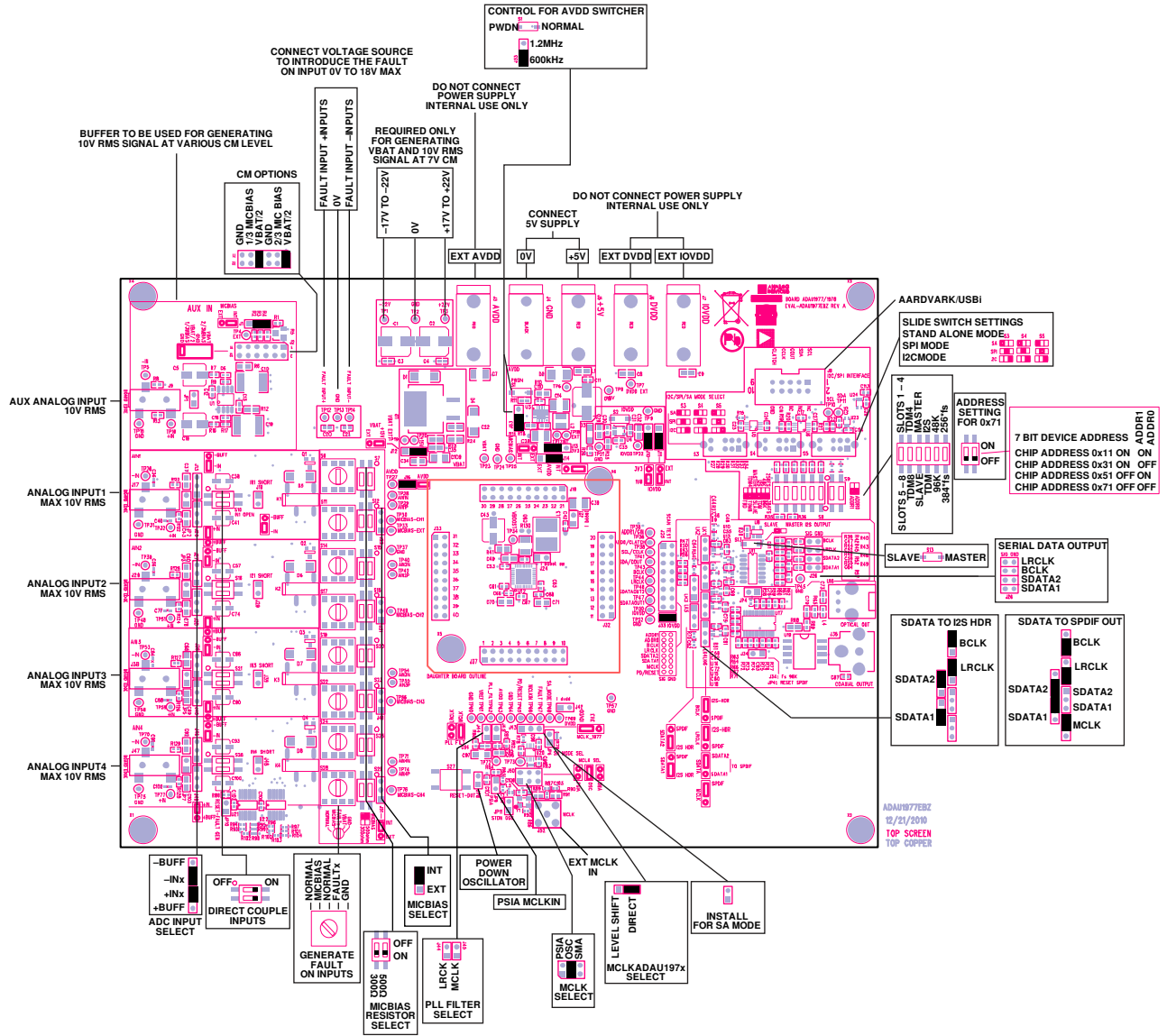

11751-002

EVALUATION BOARD SETUP INSTRUCTIONS

To setup the [EVAL-ADAU1977Z](#), the user needs a 5 V power supply, differential analog input source, and a PC with a USB port. Use a single 5 V, 1 A current rating for the power supply.

For full evaluation of the [ADAU1977](#), a ± 20 V supply is required. This power supply facilitates the generation of a 10 V rms signal as well as a VBAT supply for microphone diagnostics.

JUMPER SETTINGS

See Figure 2 for the setup of the evaluation board connections. Connect the positive power supply lead to J5 and the 0 V lead to J4 of the evaluation board. Do not turn the power supply on at this time.

In the power supply section, take the following steps:

1. Set Jumpers J13 and J14 to the **INT** position.
2. Set Switch S1 to the **ON** position.
3. Set Jumper J10 to the desired IOVDD supply, 3.3 V, or 1.8 V.
4. Set Jumper J11 to the **INT** position for the internal IOVDD.
5. Set Switch S2 to the **ON** position to turn on the 1.8 V regulator.

In the daughter board section, take the following steps:

1. Install Jumpers J16, J21, J24, and J33. The J16 jumper provides the AVDD. Jumpers J21 and J24 provide the 3.3 V power supply to the boost converter. The J33 jumper provides the IOVDD to the [ADAU1977/ADAU1978/ADAU1979](#).

In the PLL and MCLK section, take the following steps:

1. Select the master clock source. The evaluation board provides three options for providing the master clock to the ADC. The three options include the following: the on-board 12.288 MHz oscillator, the external source at JP9, and the SMA Connector J52.
2. To use the on-board oscillator, install Jumper JP11. To shut down the oscillator, remove Jumper JP11.
3. Set Jumper J50 in the **OSC** center position.
4. Alternatively, if the external master clock is available, it can either be connected at J52 as a coaxial 50 Ω SMA connector, or at JP9 as a 2-way header (0.1" pitch). If using JP9 as the source, install J50 in the **PSIA** position. If using J52 as the source, install J50 in the **SMA** position.
5. The MCLK is level shifted to the required IOVDD. By default, the level shifted master clock is used. Set Jumper J43 to the **IOVDD** position. Alternatively, if direct MCLK pin access is needed, set J43 to the **3V3** position. In this case, ensure that the master clock supplied to the [ADAU1977](#) is at the correct IOVDD level.
6. Two options are provided for the PLL filter, MCLK mode or LRCLK mode. By default, the MCLK mode is selected

by installing Jumper J44 in the **MCLK** position. If the LRCLK mode is required, set J44 in the **LRCLK** position.

In the I²S output section, take the following steps:

1. Determine the serial data format used for the ADC output. Either I²S/left justified (LJ)/right justified (RJ)/TDM format or SPDIF format are available.

For I²S/LJ/RJ/TDM format, take the following steps:

1. Set LK3 and LK5 to the **I²S** position.
2. Set LK1 and LK2 to the **I²S** position.
3. Set Switch S13 to the **MASTER** position if the [ADAU1977/ADAU1978/ADAU1979](#) is used as a master for the serial audio port. Alternatively, it can be set to the **SLAVE** position; however, in this case, both the LRCLK (frame clock) and the BCLK (bit clock) must be provided from an external source.
4. The buffered serial output is available on the J26 (4-way dual row, 0.1" pitch) header. Alternatively, the direct (unbuffered) [ADAU1977](#) serial outputs are available on the J25 (8-way dual row, 0.1" pitch) header.

For SPDIF format, take the following steps:

1. Ensure LK3 and LK5 are set to the **SPDIF** position.
2. Ensure LK1 and LK2 are set to the **SPDIF** position.
3. Ensure LK4 is set to the desired serial data pair. Either Pair 1 (Ch1 and Ch2) or Pair 2 (Ch3 and Ch4) can be selected because only 2-channel SPDIF output is available on the evaluation board.
4. Ensure LK6 is set to the **SPDIF** position which provides the MCLK to the SPDIF transmitter.
5. The SPDIF output is available on U16 as an optical form or on J35 as a coaxial form.

For the I²C/SPI control section, take the following steps:

1. Slide Switches S3, S4, and S5 are used to set the control communication protocol for the [ADAU1977](#).

For I²C protocol, take the following steps:

1. Set Switches S3, S4, and S5 to the **I²C** position.
2. Ensure JP6 is not installed.
3. The device address for the [ADAU1977](#) is set using Switch S9. The possible 7-bit device addresses are 0x11, 0x31, 0x51, or 0x71. The [EVAL-ADAU1977Z](#) evaluation board is set for the 0x71 address.
4. The 20-way (10-pin, dual row, 0.1" pitch), Shrouded Connector J8 is used to connect the supplied USBi. Alternatively, any other I²C master controller can be connected at J8 to control the [ADAU1977](#).
5. The Analog Devices, Inc., USBi is the quickest way to set the [EVAL-ADAU1977Z](#) board using the supplied standalone GUI or SigmaStudio™ software.

For the [ADAU1977](#) line input application, take the following steps:

1. J9 is used to level shift the input source to the VBAT/2 level.
2. For the [ADAU1977](#), connect the analog audio source to the J9 auxiliary input connector.
3. J2 has two jumpers that must be set to the VBAT and VBAT2 positions.
4. Check the dc voltage at J2 (Pin 2). This voltage should be approximately 7 V. If not, set J2 using the preset R5.
5. Set the S10, S16, S21, and S26 switches to the ON position for dc-coupled inputs.
6. Set Jumpers J15, J20, J27, J30, J36, J40, J46, and J49 to the BUFF position.
7. Alternatively, the signal source can be connected directly to J17, J28, J38, and J47 by setting Jumpers J15, J20, J27, J30, J36, J40, J46, and J49 to the -IN or +IN position. Note that in this setting, the input source must be level shifted appropriately.

For the [ADAU1978/ADAU1979](#) line input applications, take the following steps:

1. Ensure Jumper J15 and Jumper J20 are set to the -IN and +IN position for Ch1.
2. Ensure Jumper J27 and Jumper J30 are set to the -IN and +IN position for Ch2.
3. Ensure Jumper J36 and Jumper J40 are set to the -IN and +IN position for Ch3.
4. Ensure Jumper J46 and Jumper J49 are set to the -IN and +IN position for Ch4.
5. Ensure Switches S10, S16, S21, and S26 are set to the OFF position for the [ADAU1978](#) and the [ADAU1979](#), which sets the inputs as ac-coupled mode.

For the [ADAU1977](#) microphone input application, take the following steps:

1. Ensure Switches S7, S12, S15, S18, S20, S23, S25, and S29 are set to the ON position for using the [ADAU1977](#) inputs as microphone.
2. These switches are used to set the microphone bias resistors for the microphone inputs. Either 300 Ω or 500 Ω can be selected when switches are set to the ON position for the respective inputs.
3. Ensure Jumpers J22, J31, J41, and J51 are set to the INT position (the internal micbias is used). These jumpers allow the microphone bias to be selected either from the [ADAU1977](#), or externally, if desired.
4. Jumpers J17, J28, J38, and J47 are used for the microphone input connection.
5. Ensure Jumpers J15, J20, J27, J30, J36, J40, J46, and J49 are set to the IN position.
6. Ensure Switches S10, S16, S21, and S26 are set to the ON position for direct-coupled mode.

USBi AND STANDALONE GUI SETUP

To set up the USBi and standalone GUI, take the following steps:

1. If using the standalone GUI, click the appropriate **x86** or **x64** folder **setup.exe** to install the GUI.
2. The software is installed on your desktop with the **ADAU1977 Rev C** icon.

ADAU1977 POWER-ON

To power-on the [EVAL-ADAU1977Z](#), take the following steps:

1. Turn on the 5 V supply. Typical 40 mA current is drawn from the 5 V supply in standby condition.

STANDALONE GUI I²C CONTROL

The [EVAL-ADAU1977Z](#) board can be controlled via the I²C using the standalone GUI and USBi. Take the following steps:

1. Connect the provided USBi board to J8 and to the USB port on the PC.
2. Double-click the **ADAU1977 Rev C** icon on your desktop to invoke the GUI.
3. A new window, as is shown in Figure 3, will appear.
4. The **USBi - Connected** message will appear at the top of the window (see Figure 3).
5. Click **Power Up**. The **Communication Established** message will appear at the top of the window (see Figure 3).
6. Click **Read all** to read the PLL status. The PLL status should be green and locked.
7. When using the [ADAU1977](#), and the boost converter is turned on, the **Boost Good** indicator should be green. For the [ADAU1978](#) and the [ADAU1979](#), this function is not applicable and will stay red.
8. Go to the **ADC Control** tab (see Figure 4) and click **Master/Slave** for the ADC master mode. When green, the ADC is in master mode and it will output the bit clock and frame clock, together with the serial data at the J25.
9. Connect the input source at the desired input to AIN1, AIN2, AIN3, and AIN4 or AUXIN using 3.5 mm audio jacks. Alternatively, the 2-pin (0.1" pitch) header can be used to feed the inputs to the [EVAL-ADAU1977Z](#) evaluation board. Note that the input level requirements for the [ADAU1977](#), the [ADAU1978](#), and the [ADAU1979](#) are different, and the appropriate level input signal must be applied. The full-scale inputs for the [ADAU1977](#) is 10 V rms, for the [ADAU1978](#) is 2 V rms, and for the [ADAU1979](#) is 4.5 V rms.
10. The ADC output is available at the J26 header or the SPDIF output depending on the selected option.

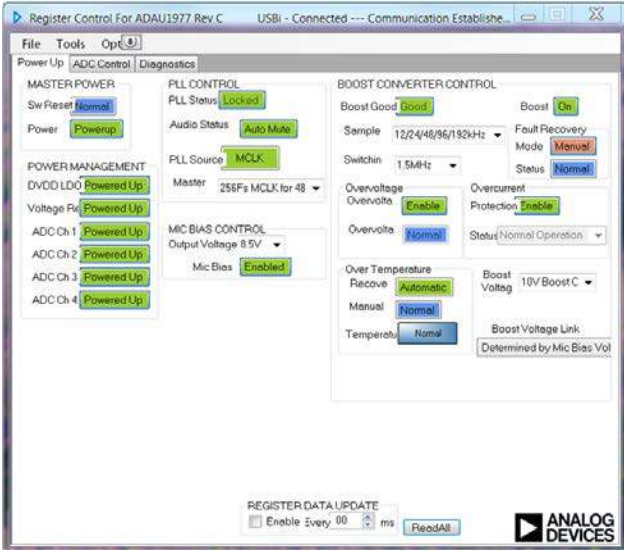

Figure 3. Register Control for the ADAU1977 GUI Page 1

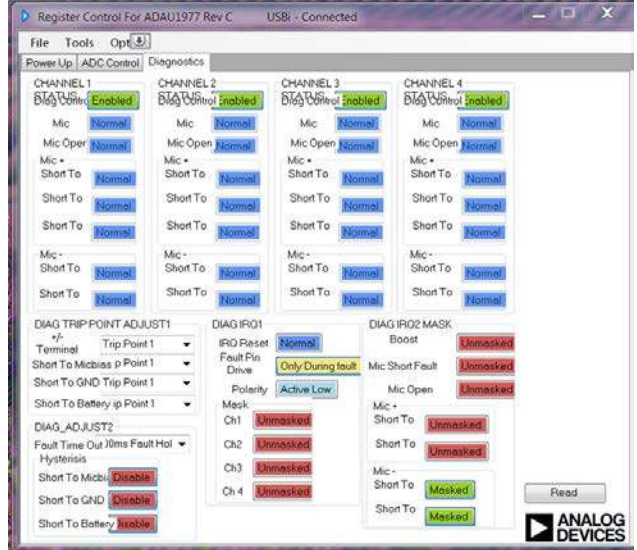

Figure 5. Register Control for the ADAU1977 GUI Page 3



Figure 4. Register Control for the ADAU1977 GUI Page 2

MICROPHONE DIAGNOSTICS

Microphone diagnostics are applicable for the ADAU1977 only, used with the microphone input application circuit, as described in the ADAU1977 data sheet.

1. Connect the microphone to the desired input connector: J17, J28, J38, or J47.
2. Ensure that the inputs are dc-coupled by setting Switches S10, S16, S21, and S26 to **On**.
3. Select the appropriate bias resistors using Switches S7 and S12 for Channel 1, Switches S15 and S18 for Channel 2, Switches S20 and S23 for Channel 3, Switches S25 and S29 for Channel 4. The resistor options are 300 Ω or 500 Ω.
4. Select the internal microphone bias by setting Jumpers J22, J31, J41, J51 to the INT position.
5. Ensure that the **Boost Good** indicator is green on the GUI **Power Up** tab.
6. Ensure **Boost** is **On**.
7. By default, the 48 k sample rate is selected, and the boost switching frequency is 1.5 MHz.
8. In the **MIC BIAS CONTROL** section, select the desired microphone bias output voltage (see Figure 3). By default, it is 8.5 V.
9. Ensure **Mic Bias** is **Enabled** (see Figure 3).
10. Check the microphone bias voltage output on the EVAL-ADAU1977Z board at the test point (TP).
11. Go to the **Diagnostics** tab on the GUI (see Figure 5).
12. With the microphone connected, the typical voltage at the positive (+) input is 2/3 of microphone bias, and at the negative (-) input is 1/3 of microphone bias.
13. Click **Read** in the **Diagnostics** tab on the GUI (see Figure 5).
14. With proper connections and normal working conditions, all of the channel status indicators will be blue for each respective channel connected with the microphone.
15. To check the diagnostics functionality, create a fault situation at the microphone input. This fault situation is done by

- either using the microphone itself or by using the dummy 300 Ω or 500 Ω resistor connected across the positive and negative input terminals of the evaluation board.
16. The faults are reported in the channel status indicators for each channel for which **Diag Control** is **Enabled** (see Figure 5).
 17. The GUI shown in Figure 5 provides access to all the diagnostics registers.
 18. The **DIAG TRIP POINT ADJUST1** section provides control for adjusting the trip thresholds (see Figure 5).
 19. The **DIAG_ADJUST2** section provides the fault timeout adjustment controls (see Figure 5).
 20. The **DIAG IRQ1** section is used to generate the IRQ using the **FAULT** pin. The **Fault Pin Drive** section is used to report the fault in the system (see Figure 5).
 21. Use the previous controls, as well as the [ADAU1977](#) diagnostics registers in this data sheet, to suit the needs of the system using the intended microphone.

1. Change Slide Switches S3, S4, and S5 to SPI mode.
2. Ensure JP6 is not installed.
3. In the GUI, go to **Options/Comm Protocol** and select SPI mode. (The default is I²C mode).
4. The evaluation board is now configured for the SPI protocol, and the GUI functions similarly to the GUI functions in I²C mode.

STANDALONE MODE

The evaluation board ([EVAL-ADAU1977Z](#)) also has a standalone mode that does not require any I²C or SPI control. In standalone mode, the [ADAU1977/ADAU1978/ADAU1979](#) are set internally for a specific operation; no register access is provided because the I²C and SPI ports are disabled. To invoke the standalone mode (SA mode), insert Jumper JP6 and set Slide Switches S3, S4, and S5 to the standalone position. In SA mode, limited options are available that can be set using the dual inline package (DIP) Switch S8. See Table 2 for the S8 switch settings.

STANDALONE GUI SPI CONTROL

The [EVAL-ADAU1977Z](#) can also be configured for SPI control instead of for I²C control. To use in SPI control mode, take the following steps:

Table 2. Settings in SA Mode

ADAU1977 Pin No., Mnemonic	Switch S8	Function	OFF		ON	
Pin 17, SDA/COU ^T	S8-6	MCLK 256 fs to 384 fs select	IOVDD	384 fs	GND	256 fs
Pin 18, SCL/CCLK	S8-5	Full-scale (FS) 48 k/96 k select	IOVDD	96 k	GND	48 k
Pin 19, ADDR0/ <u>CLATCH</u>	S8-4	I ² S/TDM select	IOVDD	TDM	GND	I ² S
Pin 20, ADDR1/CIN	S8-3	Master/slave select	IOVDD	Slave	GND	Master
Pin 14, SDATAOUT2	S8-2	TDM 4 to TDM 8 select	IOVDD	TDM 8	GND	TDM 4
Pin 8, FAULT	S8-1	TDM 8 slot assignments, Slot 1 to Slot 4 or Slot 5 to Slot 8	IOVDD	Slot 5 to Slot 8	GND	Slot 1 to Slot 4

EVALUATION BOARD SCHEMATICS AND ARTWORK

11751-006

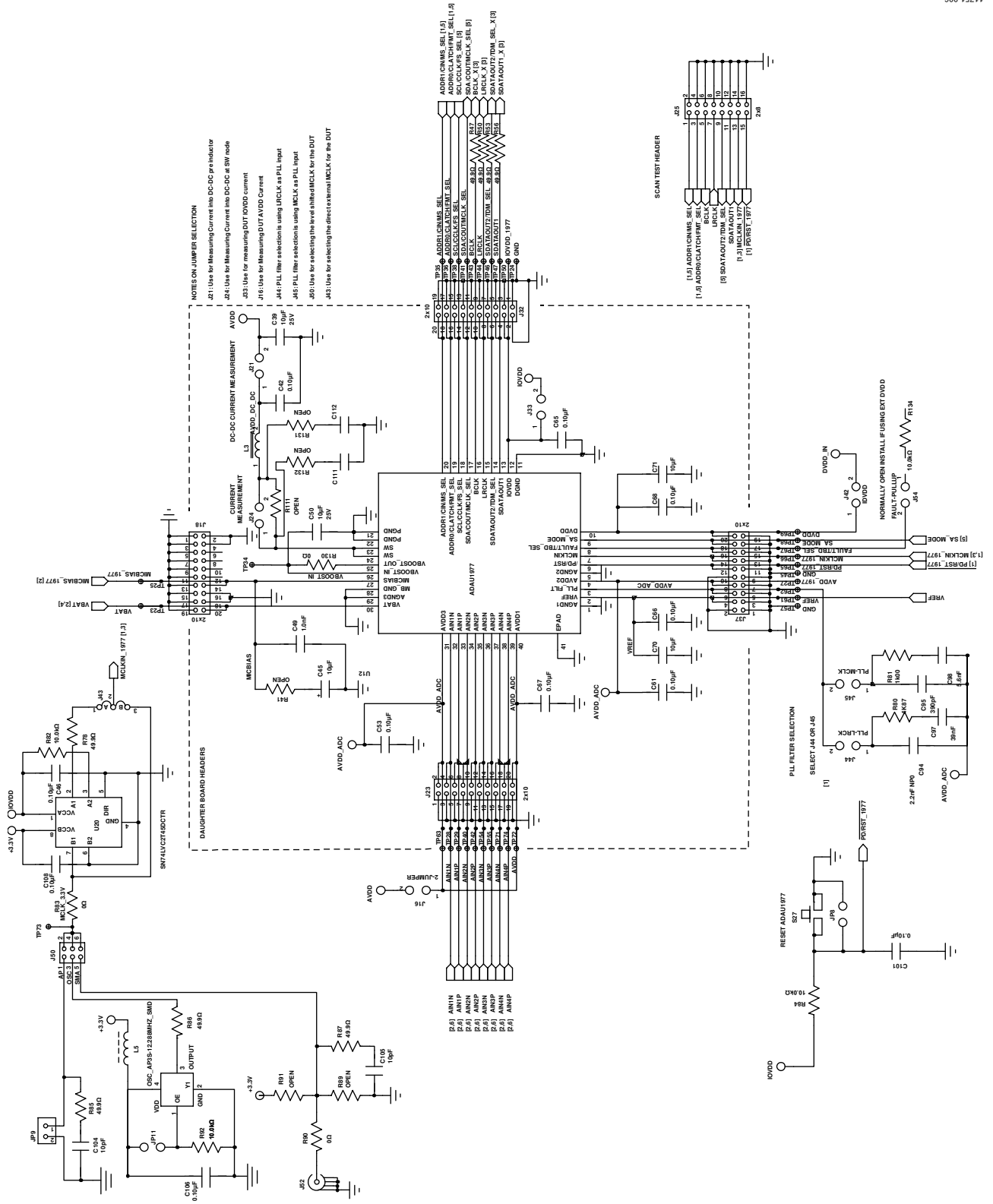

Figure 6. EVAL-ADAU1977 Schematic, Page 1 of 6

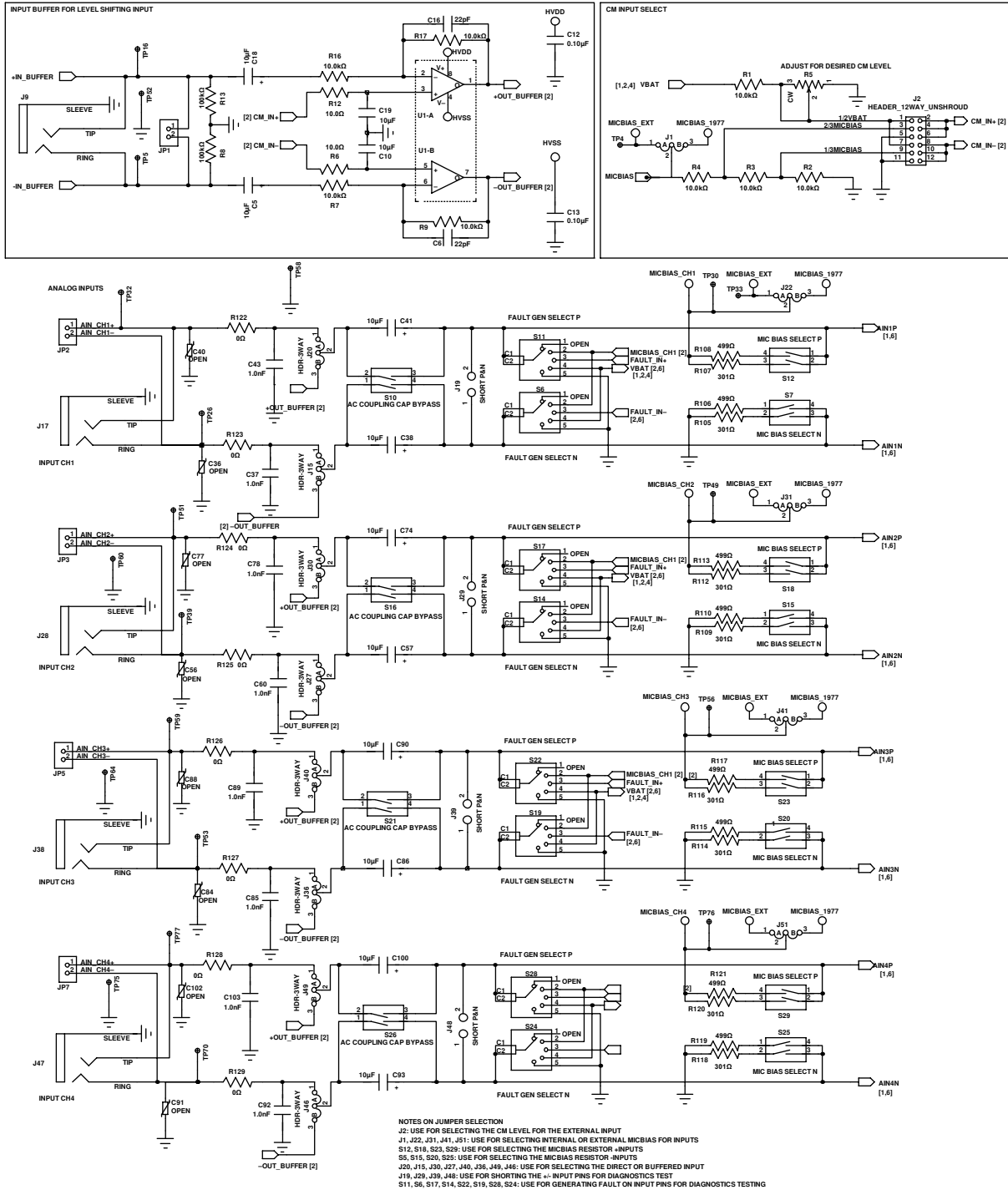
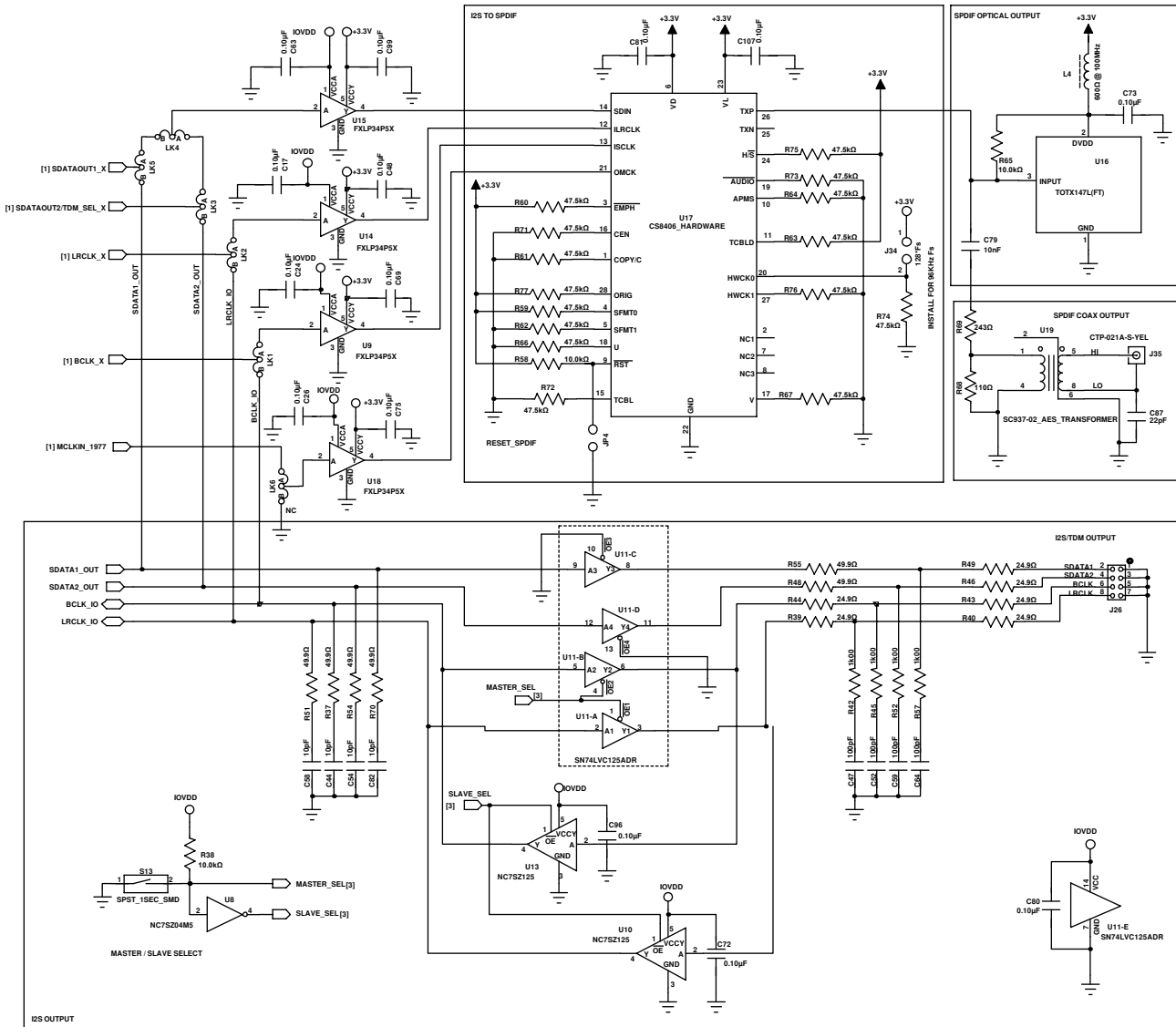

Figure 7. EVAL-ADAU1977Z Schematic, Page 2 of 6

11751-007



NOTES ON JUMPER SELECTION
 LK3, LK5: USE FOR ROUTING THE SDATA TO SPDIF OR I2S HEADER
 LK2: USE FOR ROUTING THE LRLCLK TO SPDIF OR I2S HEADER
 LK2: USE FOR ROUTING THE BCLK TO SPDIF OR I2S HEADER
 LK2: USE FOR ROUTING THE MCLKL TO SPDIF
 S13: USE FOR SELECTING THE I2S BUFFER AS MASTER OR SLAVE

Figure 8. EVAL-ADAU1977 Schematic, Page 3 of 6

11751-008

11751-009

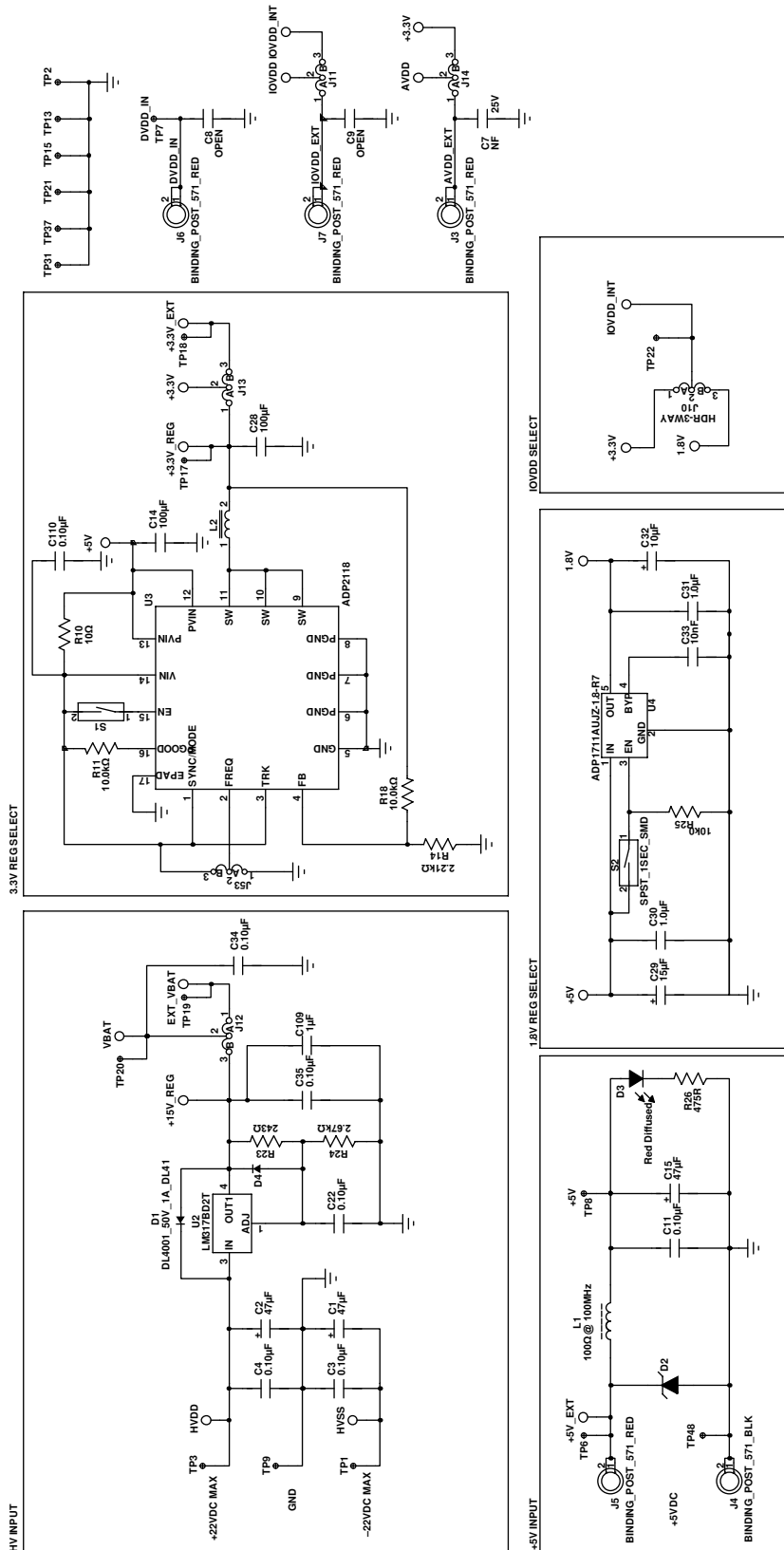

Figure 9. EVAL-ADAU1977Z Schematic, Page 4 of 6

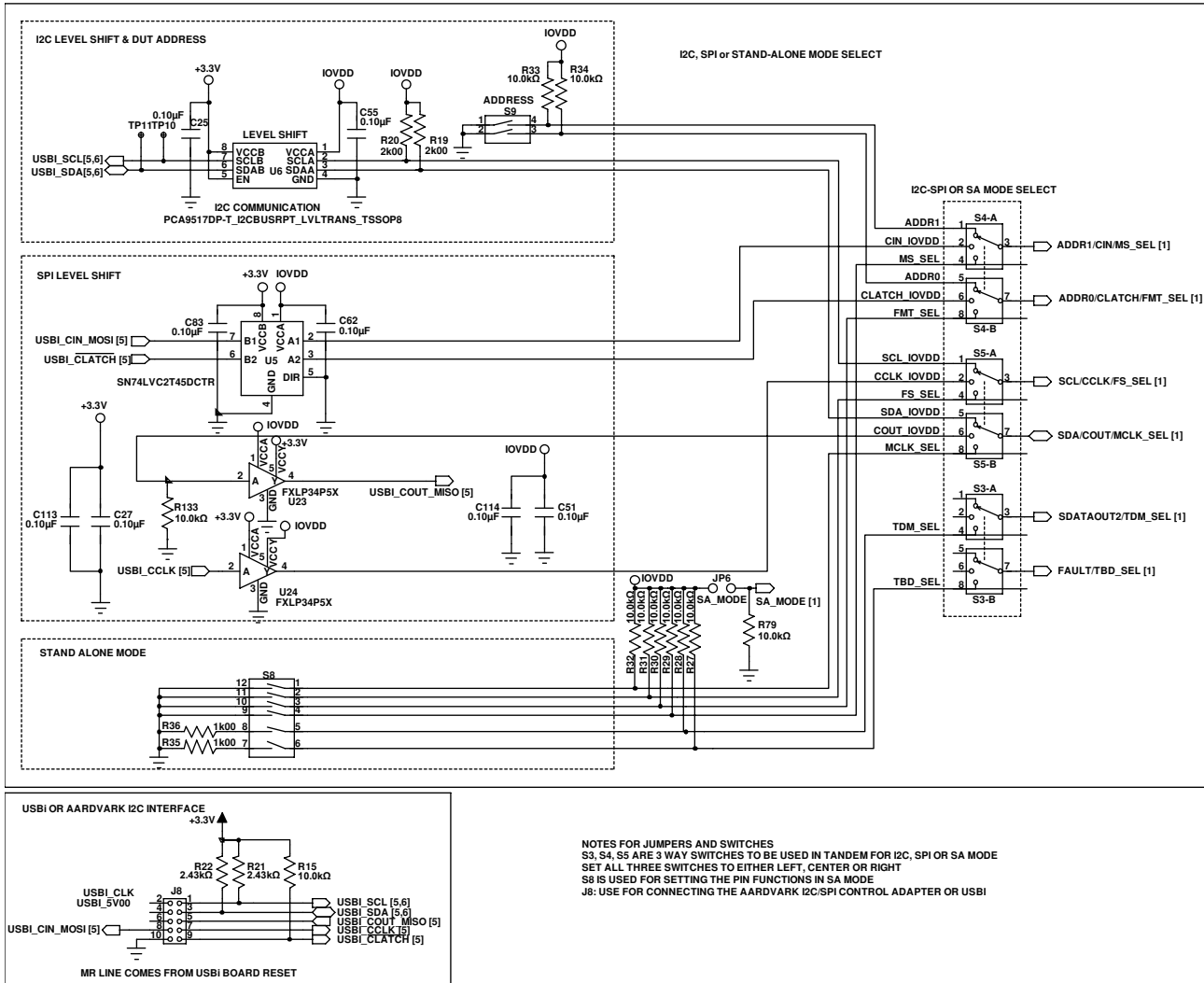

Figure 10. EVAL-ADAU1977Z Schematic, Page 5 of 6

1175-010

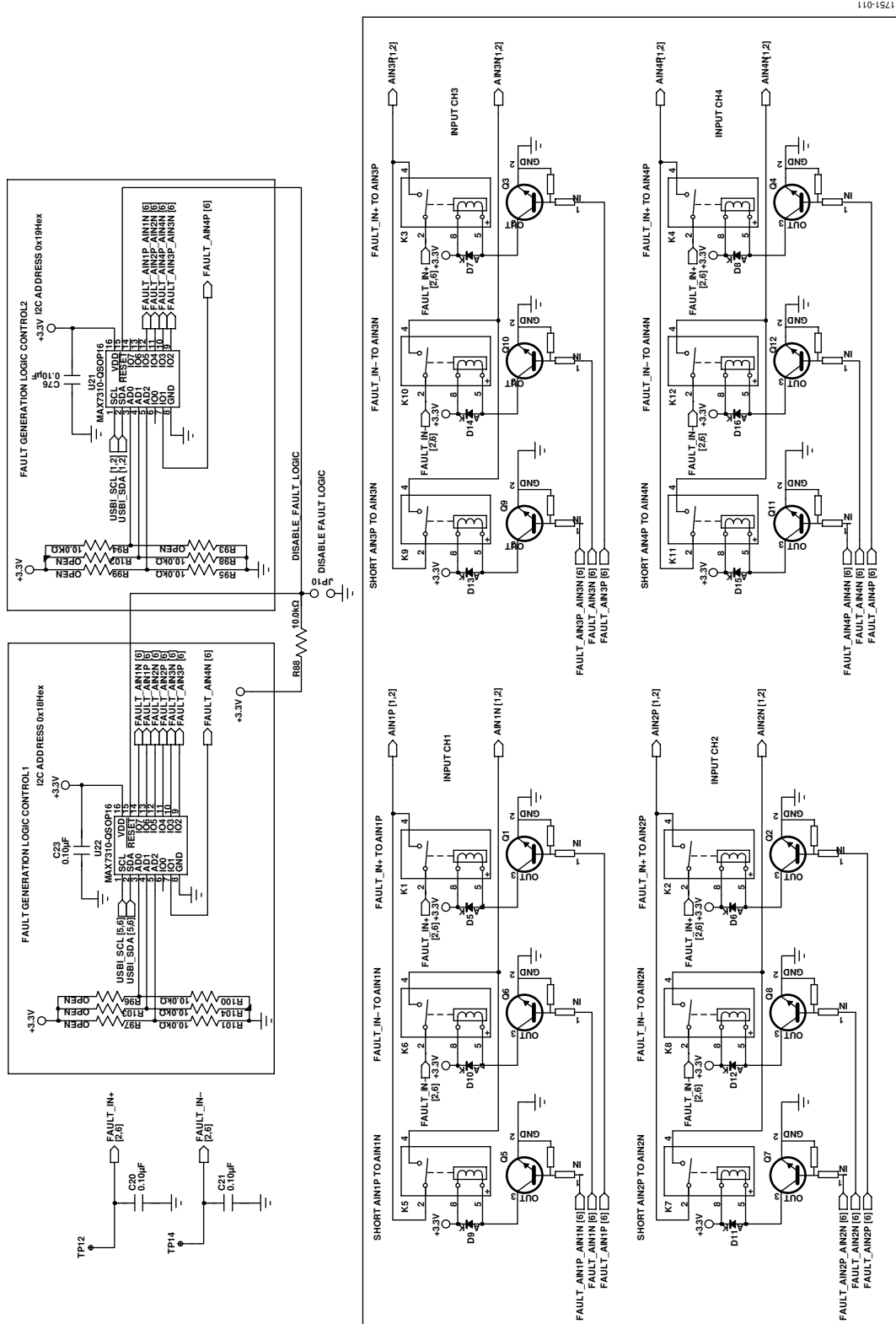

Figure 11. EVAL-ADAU1977 Schematic, Page 6 of 6

BOARD LAYOUT

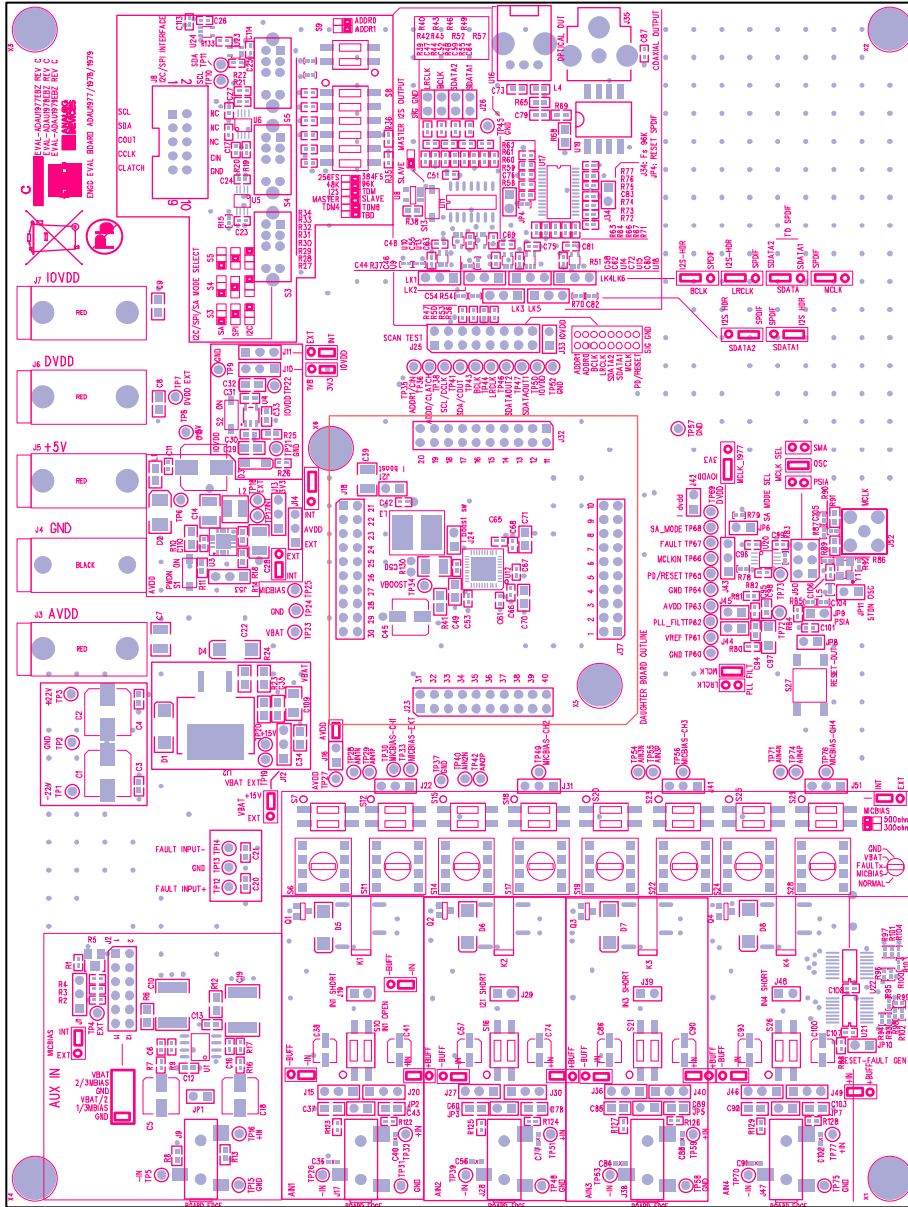
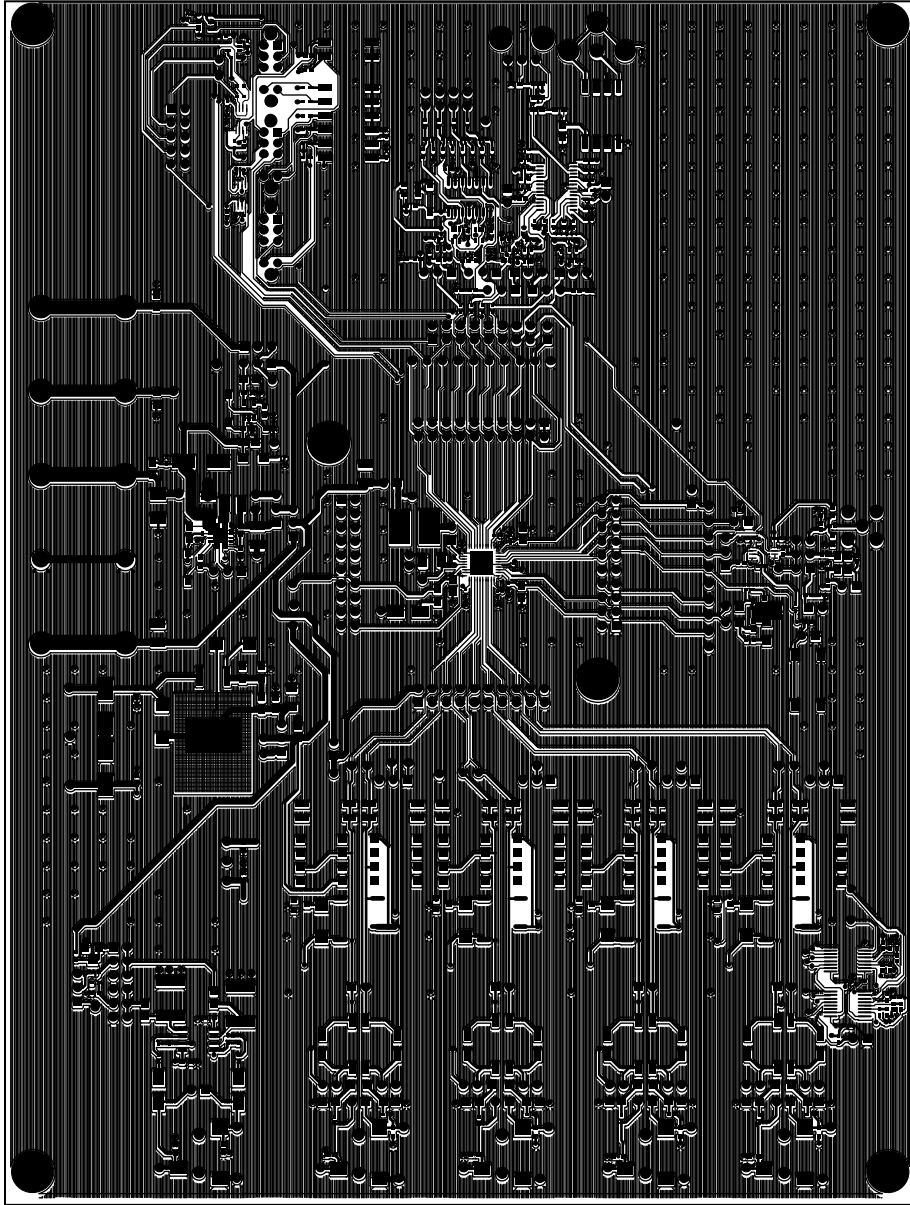

Figure 12. EVAL-ADAU1977Z/EVAL-ADAU1978Z/EVAL-ADAU1979Z Top Assembly

11751-012



11751-013

Figure 13. EVAL-ADAU1977Z Top Layer

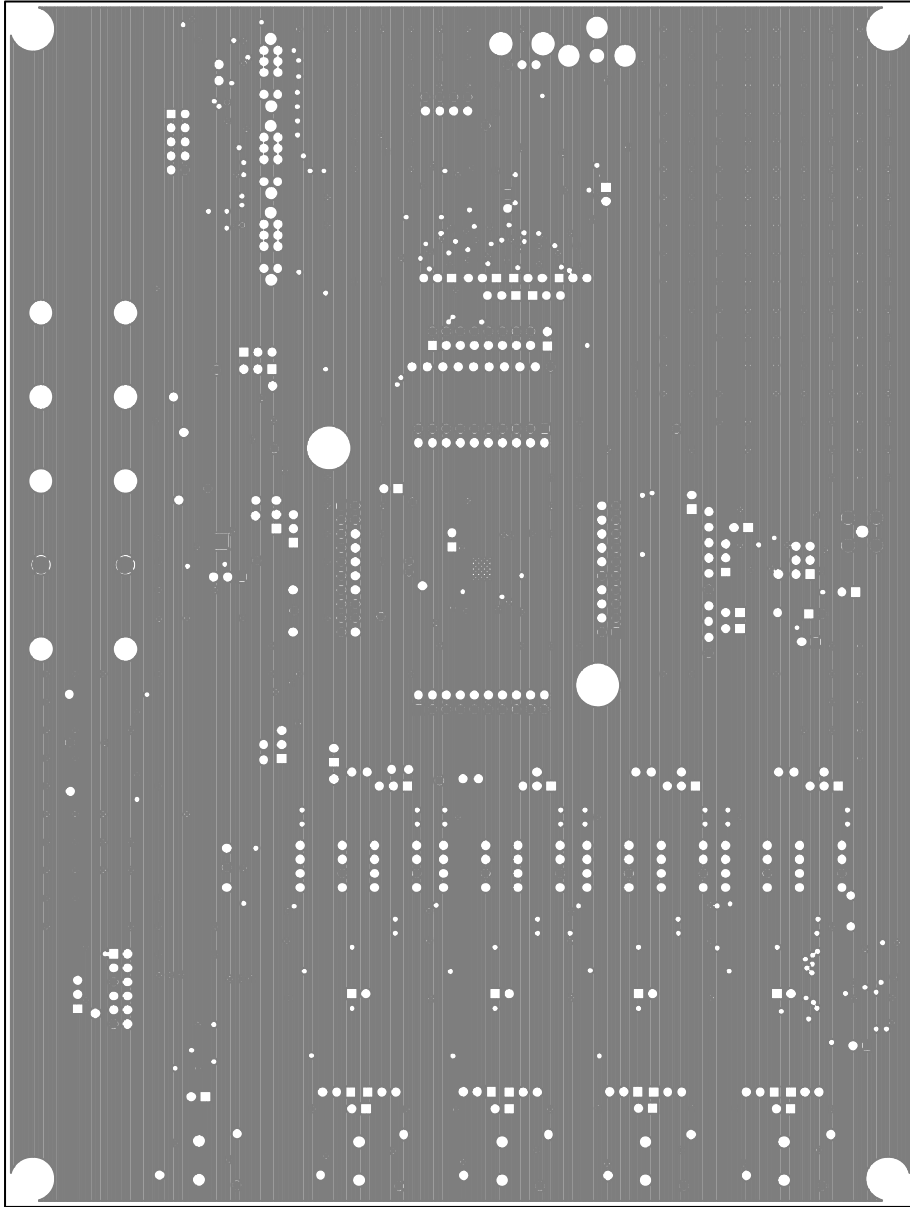

11751-014

Figure 14. EVAL-ADAU1977Z Layer 2

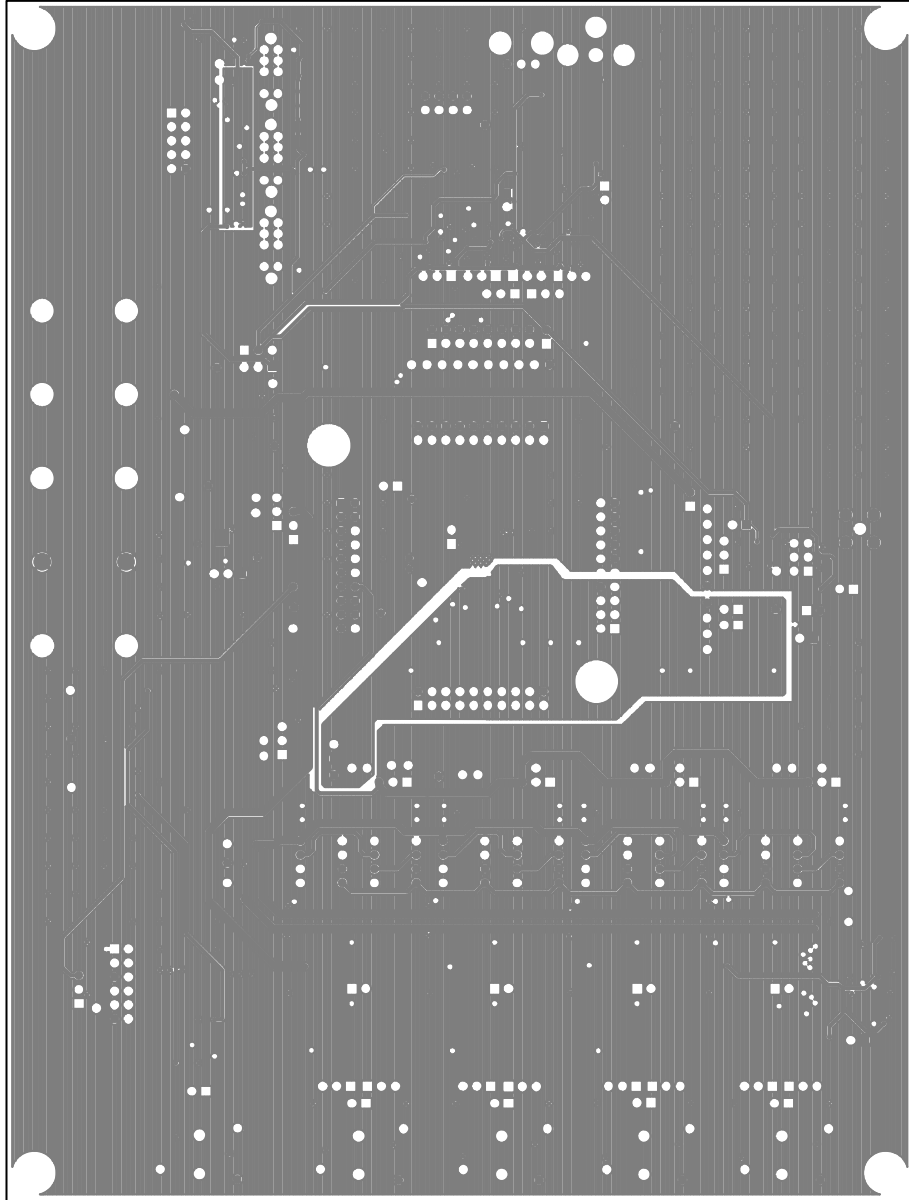

11751-015

Figure 15. EVAL-ADAU1977Z Layer 3

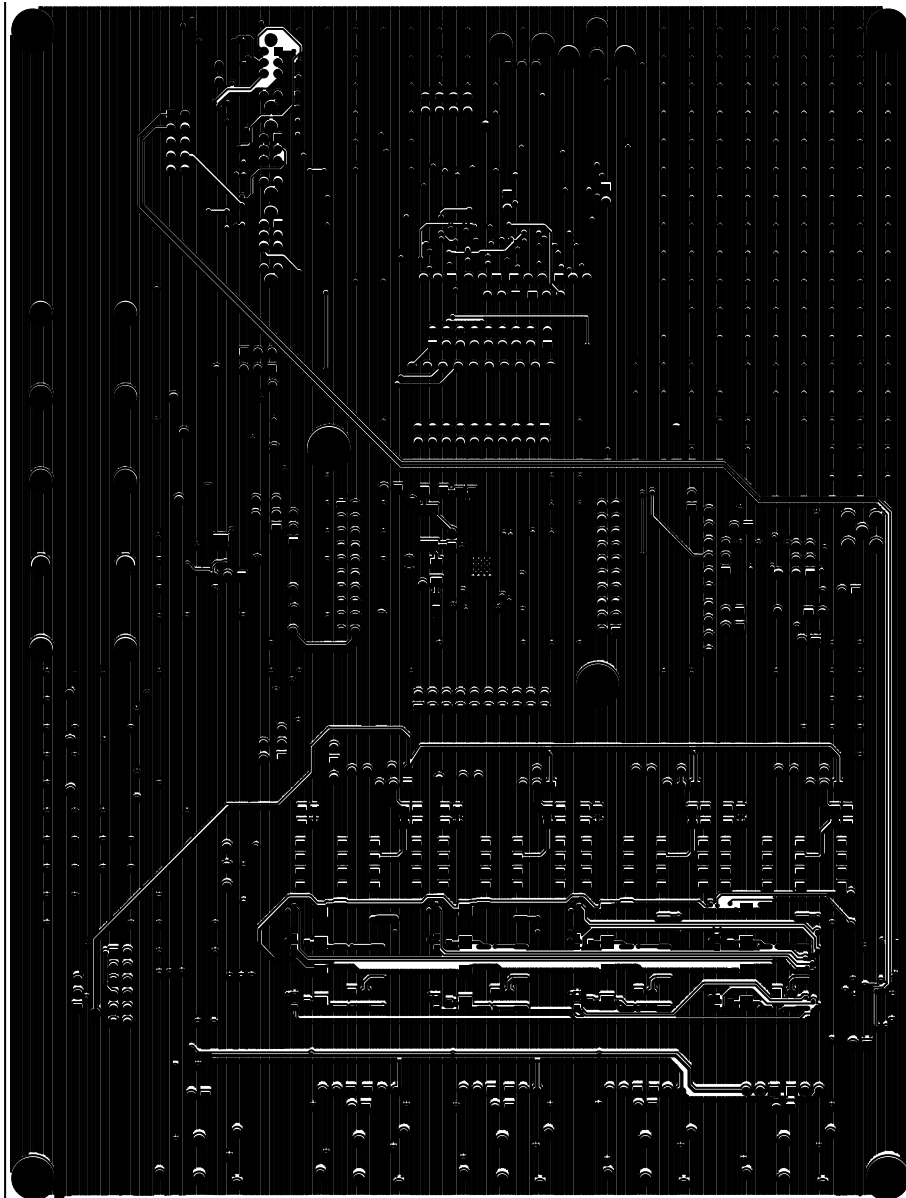

11751-016

Figure 16. EVAL-ADAU1977Z Bottom Layer

- NOTES:
- MATERIAL NO LEAD PER EU ROHS DIRECTIVE 2002/95/EC. FABRICATION TO MEET IPC-6013 CLASS 2 REQUIREMENTS. HIGH TEMPERATURE LAMINATE FR-4/FR-5 OR EQUIVALENT. UL 94V-0 PER IPC-4101/4102. USE STACKUP FOR LAYER QUANTITY AND THICKNESSES. OUTER LAYERS 16 OZ CU CLAD OVERPRINTED TO 1.15 OZ. INNER LAYERS 1 OZ.
 - SURFACE FINISH: (EXPOSED AREAS EXTERNAL LAYERS). ENIG: 5-8 MICRON INCHES IMMERSION GOLD OVER 150-200 MICRO INCHES ELECTROLESS NICKEL.
 - PLATED THROUGH HOLES MINIMUM WALL = .001 INCH THICK.
 - PROCESSING TOLERANCES:
 - CONDUCTIVE PATTERN LAYER TO LAYER REGISTRATION +/- .002 INCH TOTAL NON-ADJUSTABLE.
 - MINIMUM ANNULAR RING SUBSTRACING HOLES = .062 INCH. DOES NOT APPLY TO HOLE TYPE = 18A.
 - FINISHED CONDUCTIVE PATTERN +/- .0026 INCH OF DESIGN APERTURE DATA SIZE.
 - WARP AND TWIST PER IPC-A-600 CLASS 2 LATEST REV.
 - DIMENSIONS ARE FOR THE FINISHED PART.
 - SOLDER MASK:
 - LIQUID PHOTO IMAGEABLE (LPI) OVER BARE COPPER, (NICKEL), BOTH SIDES USING THE PROVIDED PATTERN MASKS. PER IPC-9999 LATEST REV. COLOR = BLUE.
 - SOLDERMASK TO ETCH REGISTRATION +/- .002 INCH.
 - SILKSCREEN:
 - SCREEN COMPONENT OUTLINES AND NOMENCLATURE ON THE PRIMARY AND SECONDARY SIDES (AS REQUIRED), USING NON-CONDUCTIVE OPaque EPoxy. COLOR = WHITE. NOMENCLATURE IS REQUIRED TO BE LEGIBLE. SCREENS TO ETCH REGISTRATION +/- .002 INCH.
 - NON-FUNCTIONAL PADS MAY BE REMOVED FROM INNER 60/MIL LAYERS AT VENDORS DISCRETION.
 - DESIGN RULE DATA:
 - MINIMUM SPACING, LINE TO LINE, LINE TO PAD = .007 INCH.
 - MINIMUM LINE WIDTH = .007 INCH.
 - MINIMUM VIA = .026 DIA. PAD, .214 DIA. HOLE.
 - VENDOR TO ADD UL ID NUMBER, DATE CODE, MPOR, LOGO, AND FLAMMABILITY CODE IN THIS AREA ON THE SECONDARY SIDE.
 - Fill the Thermal Via under the U3 and U12 ePAD area and pads over the pads.

4 LAYER STACKUP DETAIL

SCALE: NONE

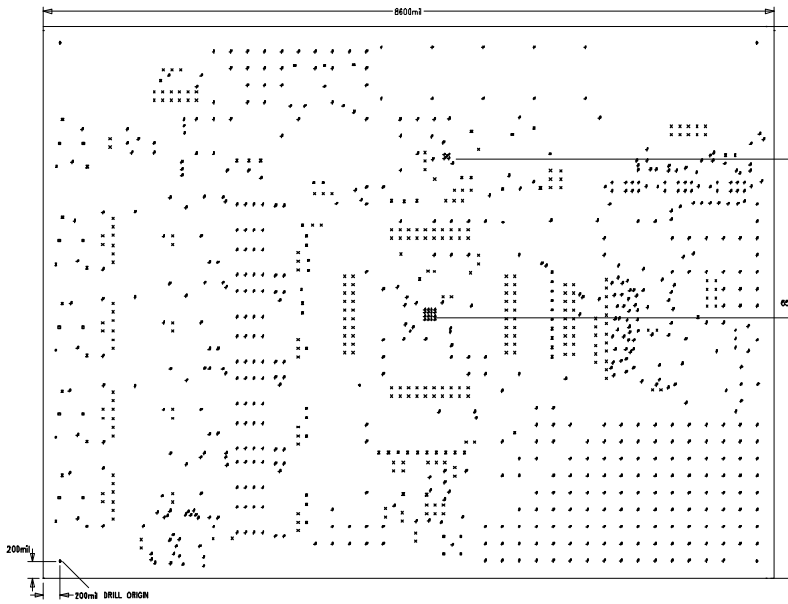
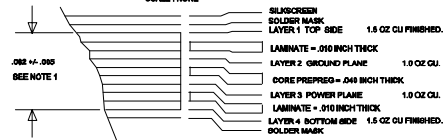

ADAU1977E2Z
12/5/2012
DRILL DRAWING
TOP COPPER

SIZE	QTY	SYM	PLATED	TOL
35	87	⊖	YES	+/-3
37	284	×	YES	+/-3
40	77	⊗	YES	+/-3
59	1	⊖	YES	+/-3
60	7	⊖	YES	+/-3
67	11	□	YES	+/-3
100	3	⊖	YES	+/-3
130	2	⊖	YES	+/-3
156	6	◇	YES	+/-3
72	10	⊖	YES	+/-3
32	24	⊖	YES	+/-3
1181	21	⊖	YES	+/-3
20	520	⊖	YES	+/-3

Figure 18. EVAL-ADAU1977Z Fabrication Drawing

11751-018

ORDERING INFORMATION

BILL OF MATERIALS

Table 3.

Qty ¹	Component Number	Description	Manufacturer	Part Number
2	C10, C19	Ceramic capacitor, 10 μ F, 50 V, X7R, 20%, 2220	Digi-Key	445-1454-1-ND
NF	C107, C108	Multilayer ceramic, 16 V, X7R (0402)	Digi-Key	PCC13490CT-ND
1	C109	Multilayer ceramic capacitors (MLCC), 50 V, X7R (1206)	Digi-Key	490-4795-6-ND
34	C11, C17, C23 to C27, C42, C46, C48, C51, C53, C55, C61 to C63, C65 to C69, C72, C75, C76, C80, C81, C83, C96, C99, C101, C106, C110, C113, C114	Ceramic capacitor, 0.1 μ F, 16 V, 10%, X7R, 0402	Digi-Key	490-3261-1-ND
NF	C111, C112	Ceramic capacitor, 1000 pF, 50 V, 10%, X7R, 0603	Digi-Key	490-1494-1-ND
3	C1, C2, C15	Aluminium electrolytic capacitor frequency converter (FC), 105°, surface-mount device E (SMD_E)	Digi-Key	PCE4008CT-ND
2	C14, C28	Multilayer ceramic, 6.3 V, X5R (1210)	Digi-Key	490-3390-1-ND
NF	C20, C21	Multilayer ceramic, 50 V, X7R (0603)	Digi-Key	PCC2398CT-ND
1	C29	Surface-mount device (SMD), tantalum capacitor, 0805, 6.3 V	Digi-Key	511-1448-1-ND
2	C30, C31	Ceramic capacitor, 1 μ F, 16 V, 10%, X7R, 0603	Digi-Key	490-3900-1-ND
1	C32	SMD, tantalum capacitor, 0805, 6.3 V	Digi-Key	511-1447-1-ND
2	C33, C79	Multilayer ceramic, 25 V, NP0 (0603)	Digi-Key	445-2664-1-ND
8	C3, C4, C12, C13, C22, C34, C35, C73	Ceramic capacitor, 0.1 μ F, 50 V, 10%, X7R, 0603	Digi-Key	490-1519-1-ND
NF	C36, C40, C56, C77, C84, C88, C91, C102	Multilayer varistor, 65 V, 0603	Digi-Key	P14254CT-ND
9	C37, C43, C49, C60, C78, C85, C89, C92, C103	Ceramic capacitor, 1000 pF, 50 V, 10%, X7R, 0603	Digi-Key	490-1494-1-ND
8	C38, C41, C57, C74, C86, C90, C93, C100	Aluminium electrolytic capacitor frequency converter (FC), 105°, surface-mount device B (SMD_B)	Digi-Key	PCE3995CT-ND
1	C39, C50	Multilayer ceramic, 25 V, X7R (1210), AECQ200	Digi-Key	490-4798-1-ND
6	C44, C54, C58, C82, C104, C105	Multilayer ceramic, 50 V, NP0 (0402)	Digi-Key	399-1011-1-ND
NF	C45	Aluminium electrolytic capacitor frequency converter (FC), 10 μ F, 50 V, 105°, radial	Digi-Key	PCE4012CT-ND
4	C47, C52, C59, C64	Multilayer ceramic, 50 V, NP0 (0402)	Digi-Key	490-4756-1-ND
2	C5, C18	Aluminium electrolytic capacitor frequency converter (FC), 10 μ F, 50 V, 105°, radial	Digi-Key	PCE4012CT-ND

Qty ¹	Component Number	Description	Manufacturer	Part Number
3	C6, C16, C87	Multilayer ceramic, 50 V, NP0 (0402)	Digi-Key	490-1283-1-ND
NF	C7	Multilayer ceramic, 25 V, X7R (1210), AECQ200	Digi-Key	490-4798-1-ND
2	C70, C71	Multilayer ceramic, 10 V, X7R (0805)	Digi-Key	490-3905-1-ND
NF	C8, C9	Multilayer ceramic, 10 V, X7R (0805)	Digi-Key	490-3905-1-ND
1	C94	Multilayer ceramic, 25 V, NP0 (0402)	Mouser	77-VJ0402Y222JXXCBC
1	C95	Multilayer ceramic, 50 V, NP0 (0402)	Digi-Key	490-1296-1-ND
1	C97	Multilayer ceramic, 25 V, NP0 (1206)	Digi-Key	490-3361-1-ND
1	C98	Multilayer ceramic, 25 V, NP0 (0603)	Digi-Key	445-2666-1-ND
2	D1, D4	Passivated rectifier 1 A, 50 V, metal oxide leadless face (MELF)	Digi-Key	DL4001-TPMSCT-ND
1	D2	Transient voltage suppressor (TVS) Zener, 15 V, 600 W, surface-mount board (SMB)	Digi-Key	1SMB15AT3GOSCT-ND
1	D3	Red diffused, 6.0 millicandela, 635 nm, 1206	Digi-Key	67-1003-1-ND
NF	D5, D16	Passivated rectifier 1 A, 50 V, metal oxide leadless face (MELF)	Digi-Key	DL4001-TPMSCT-ND
20	J1, J10 to J15, J20, J22, J27, J30, J31, J36, J40, J41, J43, J4, J6, J49, J51, J53	3-position, single inline package (SIP) header	Digi-Key	S1011E-03-ND
13	J16, J19, J21, J24, J29, J33, J34, J39, J42, J44, J45, J48, J54	2-pin header, unshrouded jumper 0.10"; use shunt Tyco 881545-2	Digi-Key	S1011E-02-ND
NF	J18, J23, J32, J37	20-way, unshrouded	Digi-Key	S2011E-10-ND
1	J2	12-way, unshrouded	Digi-Key	S2011E-06-ND
1	J25	16-way, unshrouded	Digi-Key	S2011E-08-ND
1	J26	8-way, unshrouded header, dual row	Digi-Key	S2011E-04-ND; or cut S2011E-36-ND
NF	J3, J6, J7	Binding post, mini, right angle, red, uninsulated base, through hole (TH)	Mouser	164-6220
1	J35	RCA jack, PCB through hole (TH) mount, right angle, yellow	Connect-Tech Products	CTP-021A-S-YEL
1	J4	Binding post, mini, right angle, black, uninsulated base through hole (TH)	Mouser	164-6218
1	J5	Binding post, mini, right angle, red, uninsulated base, through hole (TH)	Mouser	164-6219
1	J50	6-way, unshrouded header	Digi-Key	S2011E-03-ND
1	J52	SMA, receptacle straight, (PCB) mount	Digi-Key	ARFX1231-ND
1	J8	10-way, shroud, polarized header	Digi-Key	MHC10K-ND
5	J9, J17, J28, J38, J47	Stereo mini jack, surface-mounted (SMT)	Digi-Key	CP-3523SJCT-ND
NF	JP10	2-pin header, unshrouded	Digi-Key	S1011E-02-ND

Qty ¹	Component Number	Description	Manufacturer	Part Number
10	JP1 to J9, JP11	jumper, 0.10"; use shunt Tyco 881545-2 2-pin header, unshrouded jumper, 0.10"; use shunt Tyco 881545-2	Digi-Key	S1011E-02-ND
NF	K1 to K12	Relay Telecom, single-pole single throw (SPST), 1 A, 3 V dc SMA	Digi-Key.	Z1230-ND
1	L1	Chip ferrite bead, 100 Ω at 100 MHz	Digi-Key	587-1929-1-ND
1	L2	Inductor, 2.2 μ H, 1.7 A, SM1515	Digi-Key	490-5326-1-ND
1	L3	Inductor, 4.7 μ H, 2.4 A, surface-mount device	Digi-Key	732-1039-1-ND
1	L4	Chip ferrite bead, 600 Ω at 100 MHz	Digi-Key	445-2205-1-ND
1	L5	Chip ferrite bead, 600 Ω at 100 MHz	Digi-Key	445-2162-1-ND
6	LK1 to LK6	3-position, single inline package (SIP) header	Digi-Key	S1011E-03-ND
NF	Q1 to Q12	Negative-positive-negative (NPN), general-purpose, transistor with bias DDTTC114EKA-7-F	Digi-Key	DDTTC114EKA-7-FDICT-ND
8	R105, R107, R109, R112, R114, R116, R118, R120	Chip resistor, 1%, 125 mW, thick film, 0805	Digi-Key	P301CCT-ND
8	R106, R108, R110, R113, R115, R117, R119, R121	Chip resistor, 1%, 125 mW, thick film, 0805	Digi-Key	P499CCT-ND
3	R11, R18, R25	Chip resistor, 0.1%, 100 mW, thin film, 0603	Digi-Key	TNP10.0KAACT-ND
NF	R111	Chip resistor, 0.1%, 1 W, thick film, 0805	Digi-Key	Y1487-.01-ND
NF	R131 to R132	Chip resistor, 1%, 250 mW, thick film, 1206	Digi-Key	P10.0FCT-ND
1	R14	Chip resistor, 0.1%, 100 mW thin film, 0603	Digi-Key	TNP2.21KAACT-ND
24	R1 to R4, R7, R9, R15 to R17, R27 to R34, R58, R79, R82, R84, R92, R133, R134	Chip resistor, 1%, 63 mW, thick film, 0402	Digi-Key	P10.0KLCT-ND
2	R19, R20	Chip resistor, 1%, 63 mW, thick film, 0402	Digi-Key	P2.00KLCT-ND
2	R21, R22	Chip resistor, 1%, 63 mW, thick film, 0402	Digi-Key	P2.43KLCT-ND
1	R23	Chip resistor, 1%, 125 mW, thick film, 0805	Digi-Key	P243CCT-ND
1	R24	Chip resistor, 1%, 125 mW, thick film, 0805	Digi-Key	P2.67KCCT-ND
1	R26	Chip resistor, 1%, 63 mW, thick film, 0402	Digi-Key	P475LCT-ND
7	R35, R36, R42, R45, R52, R57, R81	Chip resistor, 1%, 63 mW, thick film, 0402	Digi-Key	P1.00KLCT-ND
14	R37, R47, R48, R50, R51, R53 to R56, R70, R78, R85 to R87	Chip resistor, 1%, 63 mW, thick film, 0402	Digi-Key	P49.9LCT-ND
2	R38, R65	Chip resistor, 1%, 125 mW, thick film, 0603	Digi-Key	P10.0KHCT-ND
6	R39, R40, R43, R44, R46, R49	Chip resistor, 1%, 63 mW, thick film, 0402	Digi-Key	P24.9LCT-ND
NF	R41	Chip resistor, 5%, 125 mW, thick film, 0805	Digi-Key	P1.0ACT-ND

Qty ¹	Component Number	Description	Manufacturer	Part Number
1	R5	Trim potentiometer, 10 k Ω linear, 3 mm, single turn, surface-mount device (SMD) top adjust	Digi-Key	490-2644-1-ND
15	R59 to R64, R66, R67, R71 to R77	Chip resistor, 1%, 63 mW, thick film, 0402	Digi-Key	P47.5KLCT-ND
3	R6, R10, R12	Chip resistor, 1%, 125 mW, thick film, 0805	Digi-Key	P10.0CCT-ND
1	R68	Chip resistor, 1%, 125 mW, thick film, 0805	Digi-Key	P110CCT-ND
1	R69	Chip resistor, 1%, 100 mW, thick film, 0603	Digi-Key	P243HCT-ND
2	R8, R13	Chip resistor, 1%, 125 mW, thick film, 0603	Digi-Key	P100KHCT-ND
1	R80	Chip resistor, 1%, 63 mW, thick film, 0402	Digi-Key	P4.87KLCT-ND
11	R83, R90, R122 to R130	Chip resistor, 5%, 63 mW, thick film, 0402	Digi-Key	P0.0JCT-ND
NF	R88, R93, R95, R98, R100, R101, R104	Chip resistor, 1%, 63 mW, thick film, 0402	Digi-Key	RHM10.0KLCT-ND
NF	R89, R91	Chip resistor, 1%, 100 mW, thick film, 0603	Digi-Key	P100HCT-ND
NF	R94, R96, R97, R99, R102, R103	Do not stuff	OPEN	OPEN
3	S1 to S2, S13	1 section, single-pole single throw, (SPST), surface-mount device (SMD)	Digi-Key	563-1003-1-ND
1	S27	Tact switch, 6 mm gull wing	Digi-Key	450-1133-ND
3	S3 to S5	Switch glide, DP3T PC, mount L = 4 mm	Digi-Key	EG1920-ND
NF	S6, S11, S14, S17, S19, S22, S24, S28	Switch rotary, 1P5T, top adjust through hole	Digi-Key	563-1078-ND
13	S7, S9, S10, S12, S15, S16, S18, S20 to S21, S23, S25, S26, S29	2 section, single-pole single throw, surface-mount device, switch raised act	Digi-Key	CT2192LPST-ND
1	S8	6 section, single-pole single throw, surface-mount device, switch raised act	Digi-Key	CT2196LPST-ND
75	TP1 to TP11, TP15 to TP77	Mini test point, white, 1" outer diameter	Digi-Key	5002K-ND
NF	TP12 to TP14	Mini test point, white, 1" outer diameter	Digi-Key	5002K-ND
1	U1	Dual bipolar/junction, field effect transistor (JFET), audio operational amplifier.	Analog Devices Inc.	OP275GSZ
2	U10, U13	IC, buffer tristate, noninverting, SC70-5	Digi-Key	NC7SZ125P5XCT-ND
1	U11	Quad buffer, tristate, 14-lead SOIC	Digi-Key	296-8453-1-ND
1	U12	IC, 4-channel ADC with diagnostics, ADAU1977 40-lead LFCSP	Analog Devices, Inc.	ADAU1977WBCPZ
1	U16	Fiber optic transmit module, 15 Mbs with shutter	Digi-Key	TOTX147L-ND
1	U17	192 kHz, Sony Philips digital interface format (SPDIF) transmitter	Newark In One	88H6508
1	U19	110 Ω audio, Engineering Society/European Broadcaster Union (AES/EBU)	Scientific Conversion Inc.	SC937-02

Qty ¹	Component Number	Description	Manufacturer	Part Number
1	U2	transformer Integrated circuit, positive voltage regulator LM317, adjust, D2PAK	Digi-Key	LM317BD2TR4GOSCT-ND
NF	U21, U22	Integrated circuit, I ² C, 8-bit, input/output expander	Digi-Key	MAX7310AEE+-ND
1	U3	Step down, dc to dc, voltage regulator, ADP2118	Digi-Key	ADP2118ACPZ-R7CT-ND
1	U4	Adjustable, low dropout, voltage regulator	Analog Devices	ADP1711AUJZ-1.8-R7
2	U5, U20	Integrated circuit, 2-bit, dual bus TXRX, 8-lead shrink small outline package (SSOP)	Digi-Key	296-16845-1-ND
1	U6	Integrated circuit, I ² C bus repeater, 8-lead thin shrink small outline package (TSSOP)	Digi-Key	568-1829-2-ND
1	U8	Integrated circuit, tiny logic inverter, NC7SZ04	Digi-Key	NC7SZ04M5CT-ND
6	U9, U14, U15, U18, U23, U24	Translator, 1-bit, unidirect, SC70-5	Digi-Key	FXLP34P5XCT-ND
1	Y1	12.288 fixed, surface-mount device (SMD) oscillator, 1.8 V to 3.3 V voltage direct current (VDC)	Digi-Key	AP3S-12.288MHZ-F-J-B

¹ NF: not fitted or do not populate; ALT: alternate or equivalent.



ESD Caution

ESD (electrostatic discharge) sensitive device. Charged devices and circuit boards can discharge without detection. Although this product features patented or proprietary protection circuitry, damage may occur on devices subjected to high energy ESD. Therefore, proper ESD precautions should be taken to avoid performance degradation or loss of functionality.

Legal Terms and Conditions

By using the evaluation board discussed herein (together with any tools, components documentation or support materials, the "Evaluation Board"), you are agreeing to be bound by the terms and conditions set forth below ("Agreement") unless you have purchased the Evaluation Board, in which case the Analog Devices Standard Terms and Conditions of Sale shall govern. Do not use the Evaluation Board until you have read and agreed to the Agreement. Your use of the Evaluation Board shall signify your acceptance of the Agreement. This Agreement is made by and between you ("Customer") and Analog Devices, Inc. ("ADI"), with its principal place of business at One Technology Way, Norwood, MA 02062, USA. Subject to the terms and conditions of the Agreement, ADI hereby grants to Customer a free, limited, personal, temporary, non-exclusive, non-sublicensable, non-transferable license to use the Evaluation Board FOR EVALUATION PURPOSES ONLY. Customer understands and agrees that the Evaluation Board is provided for the sole and exclusive purpose referenced above, and agrees not to use the Evaluation Board for any other purpose. Furthermore, the license granted is expressly made subject to the following additional limitations: Customer shall not (i) rent, lease, display, sell, transfer, assign, sublicense, or distribute the Evaluation Board; and (ii) permit any Third Party to access the Evaluation Board. As used herein, the term "Third Party" includes any entity other than ADI, Customer, their employees, affiliates and in-house consultants. The Evaluation Board is NOT sold to Customer; all rights not expressly granted herein, including ownership of the Evaluation Board, are reserved by ADI. CONFIDENTIALITY. This Agreement and the Evaluation Board shall all be considered the confidential and proprietary information of ADI. Customer may not disclose or transfer any portion of the Evaluation Board to any other party for any reason. Upon discontinuation of use of the Evaluation Board or termination of this Agreement, Customer agrees to promptly return the Evaluation Board to ADI. ADDITIONAL RESTRICTIONS. Customer may not disassemble, decompile or reverse engineer chips on the Evaluation Board. Customer shall inform ADI of any occurred damages or any modifications or alterations it makes to the Evaluation Board, including but not limited to soldering or any other activity that affects the material content of the Evaluation Board. Modifications to the Evaluation Board must comply with applicable law, including but not limited to the RoHS Directive. TERMINATION. ADI may terminate this Agreement at any time upon giving written notice to Customer. Customer agrees to return to ADI the Evaluation Board at that time. LIMITATION OF LIABILITY. THE EVALUATION BOARD PROVIDED HEREUNDER IS PROVIDED "AS IS" AND ADI MAKES NO WARRANTIES OR REPRESENTATIONS OF ANY KIND WITH RESPECT TO IT. ADI SPECIFICALLY DISCLAIMS ANY REPRESENTATIONS, ENDORSEMENTS, GUARANTEES, OR WARRANTIES, EXPRESS OR IMPLIED, RELATED TO THE EVALUATION BOARD INCLUDING, BUT NOT LIMITED TO, THE IMPLIED WARRANTY OF MERCHANTABILITY, TITLE, FITNESS FOR A PARTICULAR PURPOSE OR NON-INFRINGEMENT OF INTELLECTUAL PROPERTY RIGHTS. IN NO EVENT WILL ADI AND ITS LICENSORS BE LIABLE FOR ANY INCIDENTAL, SPECIAL, INDIRECT, OR CONSEQUENTIAL DAMAGES RESULTING FROM CUSTOMER'S POSSESSION OR USE OF THE EVALUATION BOARD, INCLUDING BUT NOT LIMITED TO LOST PROFITS, DELAY COSTS, LABOR COSTS OR LOSS OF GOODWILL. ADI'S TOTAL LIABILITY FROM ANY AND ALL CAUSES SHALL BE LIMITED TO THE AMOUNT OF ONE HUNDRED US DOLLARS (\$100.00). EXPORT. Customer agrees that it will not directly or indirectly export the Evaluation Board to another country, and that it will comply with all applicable United States federal laws and regulations relating to exports. GOVERNING LAW. This Agreement shall be governed by and construed in accordance with the substantive laws of the Commonwealth of Massachusetts (excluding conflict of law rules). Any legal action regarding this Agreement will be heard in the state or federal courts having jurisdiction in Suffolk County, Massachusetts, and Customer hereby submits to the personal jurisdiction and venue of such courts. The United Nations Convention on Contracts for the International Sale of Goods shall not apply to this Agreement and is expressly disclaimed.

©2014 Analog Devices, Inc. All rights reserved. Trademarks and registered trademarks are the property of their respective owners.
UG11751-0-8/14(0)



www.analog.com