

THIS DRAWING IS UNPUBLISHED.

RELEASED FOR PUBLICATION

,19

© COPYRIGHT 19

BY AMP INCORPORATED. ALL RIGHTS RESERVED.

LOC DS

DIST

REVISIONS

P	LTR	DESCRIPTION	DATE	DWN	APVD
O		RELEASED(ME95-200)	13/NOV '95	YD	JK
A		REVISED(RD96-302)	25/OCT '96	TD	CS
B		REVISED(RD97-205)	1/OCT '97	YD	JK
C		REVISED(RD98-063)	16/MAR '98	YD	CS
D		REVISED(FC00-0108-98)	8/DEC '98	YD	CS
E		REVISED(FC00-0081-99)	30/JUN '99	YD	CS

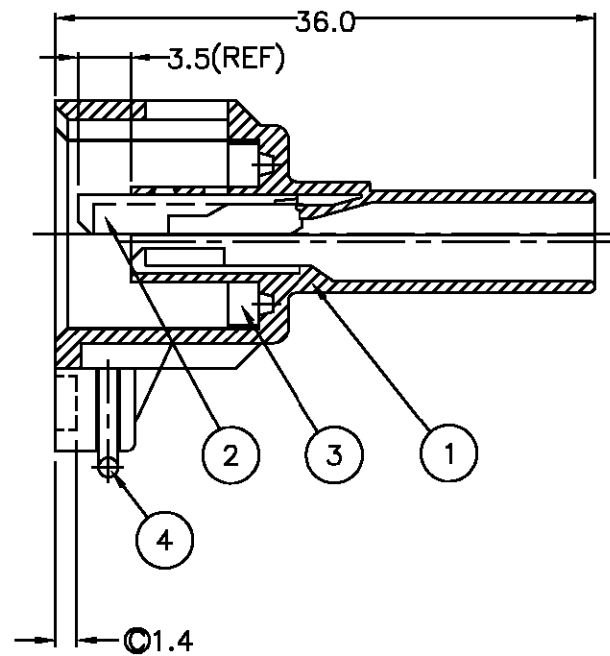
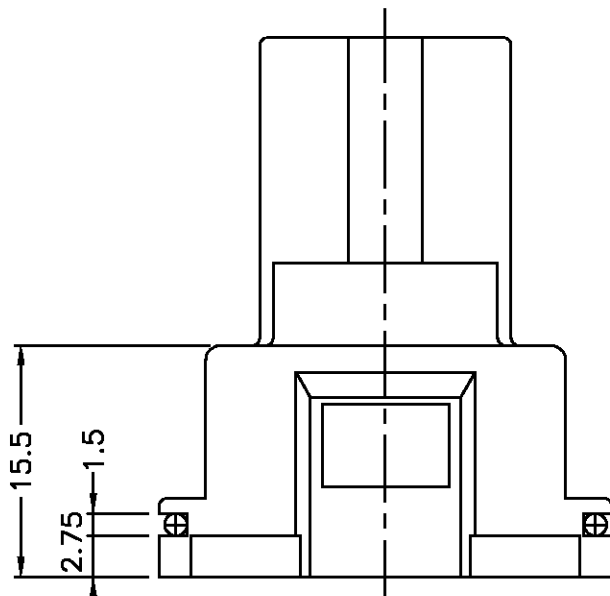

\* NOTES \*

- 1. APPLICABLE CONTACT P/NO: 927770/927766
- 2. APPLICABLE WIRE SEAL P/NO: 828904/828905/368064

P/NO	DESCRIPTION
368000-3 (D)	JPT 3P ASSY FOR HMC
368000-2 (B)	JPT 3P ASSY FOR CPS SENSOR
368000-1 (A)	JPT 3P ASSY FOR INJECTOR

NO	P/NO	DESCRIPTION	MATERIAL	COLOR	REQUIRED QTY
4	85388-1	SPRING	SUS 304		1
3	85384-2	SEAL RUBBER	SILICONE	BLUE	1
2	85207-1	SPACER	PBT	YELLOW	1
1	(D) 368001-3	JPT 3P HSG FOR HMC	PBT 30% GF	ROSE	1
1	(B) 368001-2	JPT 3P HSG FOR CPS SENSOR	PBT 30% GF	LIGHT BLUE	1
1	368001-1	JPT 3P HSG FOR INJECTOR	PBT 30% GF	BLACK	1

THIS DRAWING IS A CONTROLLED DOCUMENT FOR AMP INCORPORATED. IT IS SUBJECT TO CHANGE AND THE CONTROLLING ENGINEERING ORGANIZATION SHOULD BE CONTACTED FOR THE LATEST REVISION.

DIMENSIONS: MM 3rd ANGLE PROJECTION		TOLERANCES UNLESS OTHERWISE SPECIFIED: 0<XX<10 ± 0.2 10<XX<30 ± 0.25 30<XX<100 ± 0.3 ANGLES ± 3°		DWN CHK APVD PRODUCT SPEC 108-61000 APPLICATION SPEC 114-18018 WEIGHT 6.20g		<b>AMP</b> AMP KOREA. kyungsan, korea NAME JPT 3P ASS'Y FOR INJECTOR SIZE A3 CAGE CODE 00779 DRAWING NO C- 368000	
MATERIAL		FINISH		SCALE 2/1		SHEET 1 OF 1	
						REV E	