

- ① HOUSING: GLASS FILLED POLYESTER; COLOR: BLACK.
- ② CONTACT: PHOSPHOR BRONZE.
- ③ NICKEL UNDERPLATE: 0.00127 [.000050] MIN - ALL OVER.
- ④ TIN-LEAD PLATE: 0.00254 [.000100] MIN - SOLDER POSTS.
- ⑤ GOLD PLATE: 0.00076 [.000030] MIN - CONTACT AREA.
- ⑥ NICKEL PLATE PER MIL-G-45204. GOLD PLATE PER QQ-N-290.
- △ TE PART NUMBER, DATE CODE AND CSA LOGO ARE MARKED IN APPROXIMATE AREA SHOWN, EITHER SIDE.
- 8. RECOMMENDED PCB FINISHED HOLE DIA: 1.02±0.08 [.040±.003].
- ⑨ THE RETENTION FEATURE OF THIS CONNECTOR IS DESIGNED FOR FULL SEATING IN A .062±.008 THICK CIRCUIT BOARD, #119231-1 H.

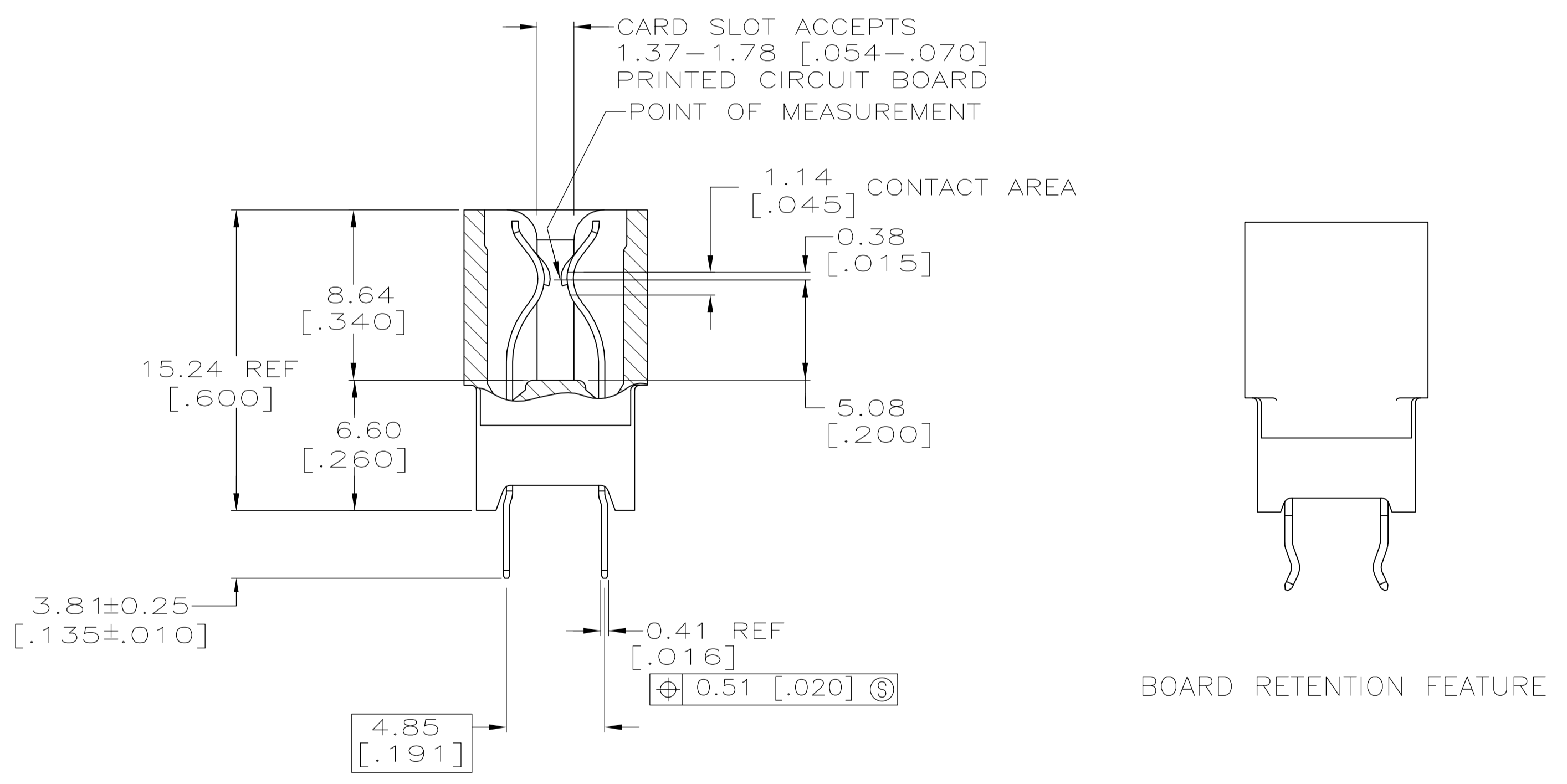
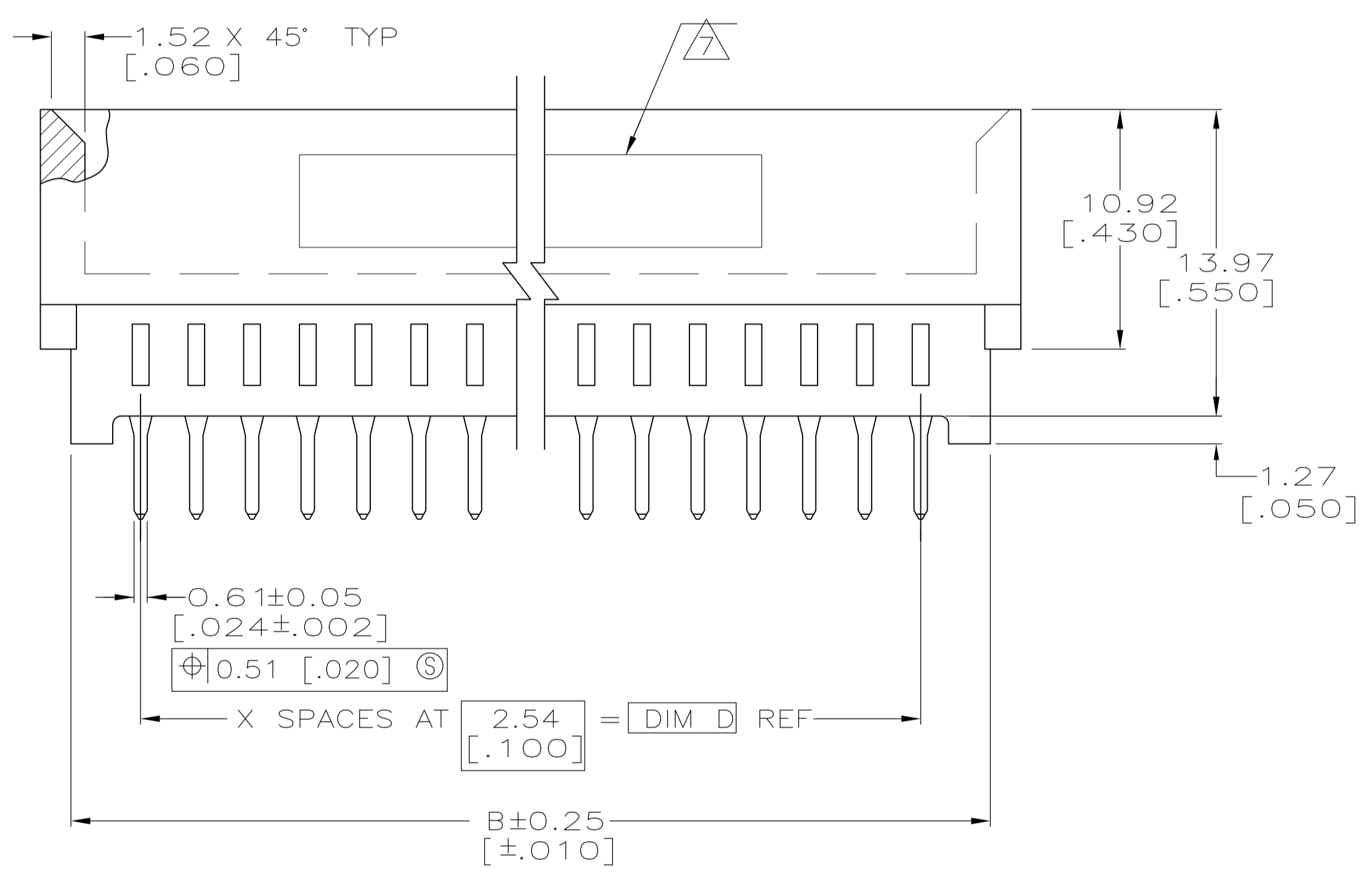
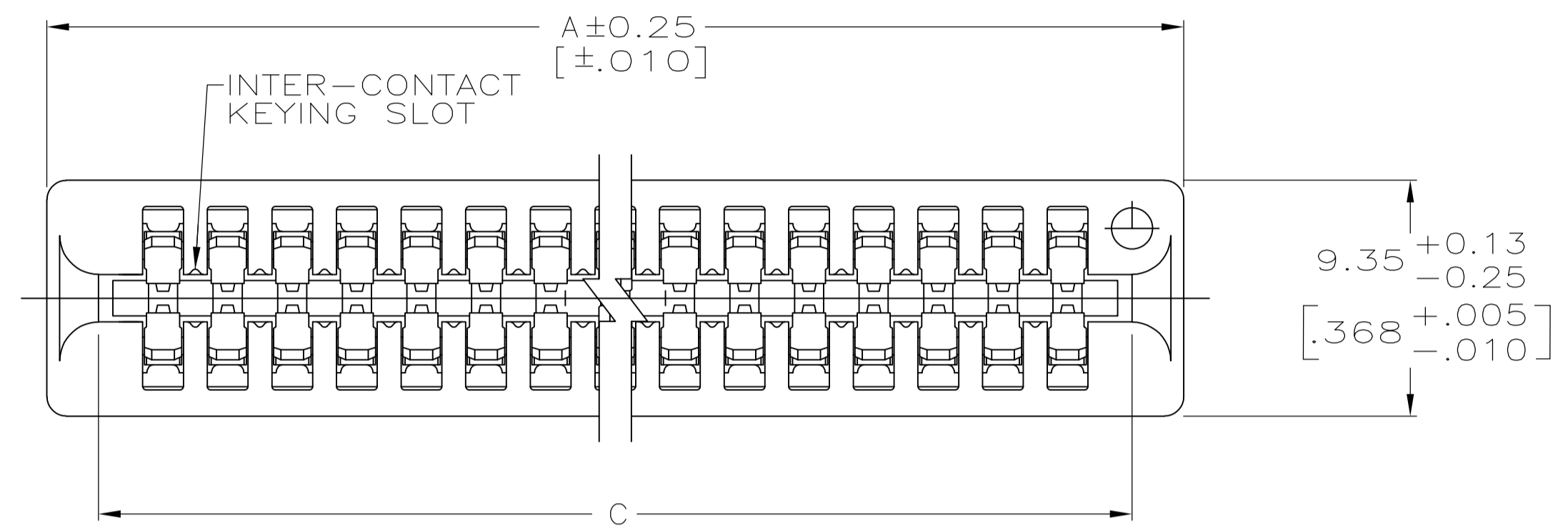

| | | | | | | | |
|----------------------------|---------------|---------------|---------------|---------------|----|------------|-------------|
| 3,4,23,24 | 30.48 [1.200] | 35.56 [1.400] | 36.83 [1.450] | 39.62 [1.560] | 12 | 13 | 145274-1 |
| RETENTION FEATURE LOCATION | D | C | B | A | X | NO OF POSN | PART NUMBER |

THIS DRAWING IS A CONTROLLED DOCUMENT.

| | | | | | |
|------------------|--|----------------------|------------------------------|---------------------------|---------------|
| DIMENSIONS: mm | TOLERANCES UNLESS OTHERWISE SPECIFIED: | DIN R BROWN 1/9/97 | APVD S. FLICKINGER 09JUN2008 | NAME | RESTRICTED TO |
| 0. PLC ± - | 1. PLC ± - | 2. PLC ± 0.13 [.005] | 3. PLC ± - | 4. PLC ± - | ANGLES ± ° |
| MATERIAL | FINISH | 1/2 | 3/4/5 | SIZE CAGE CODE DRAWING NO | WEIGHT |
| | | | | A1 00779 C=145274 | |
| CUSTOMER DRAWING | | SCALE 4:1 | SHEET 1 OF 1 | REV H | |

Tyco Electronics Corporation
 Harrisburg, Pa 17105-3608

CONNECTOR ASSEMBLY, STANDARD EDGE II, 2.54 [.100]