

# Plastic Infrared Emitting Diode

OP265 (A, B), OP266 (A, B, D, W)  
Obsolete (OP265D, OP265W)



## Features:

- T-1 (3 mm) package style
- Choice of narrow or wide irradiance pattern
- Choice of dome or flat lens
- Mechanically and spectrally matched to other OPTEK devices
- Higher power output than GaAs at equivalent drive currents
- 890 nm diodes

## Description:

Each device in the **OP265** and **OP266** series is a high intensity gallium aluminum arsenide infrared emitting diode (GaAlAs) that is molded in an IR transmissive clear epoxy package with either a dome or flat lens. Devices feature narrow and wide irradiance patterns and a variety of electrical characteristics. The small T-1 package style makes these devices ideal for space-limited applications.

OP265 devices conform to the OP505 and OP535 series devices. OP266 devices conform to OP506 series devices.

Please refer to Application Bulletins 208 and 210 for additional design information and reliability (degradation) data.

## Applications:

- Space-limited applications
- Applications requiring coupling efficiency
- Battery-operated or voltage-limited applications

Ordering Information					
Part Number	LED Peak Wavelength	Output Power (mW/cm <sup>2</sup> ) Min / Max	I <sub>F</sub> (mA) Typ / Max	Total Beam Angle	Lead Length
OP265A	890 nm	2.70 / NA	20 / 50	18°	See page 2
OP265B		1.65 / 4.70			
OP265D (Obsolete)		0.54 / NA			
OP265W (Obsolete)		1.00 / NA			
OP266A		2.70 / NA		18°	
OP266B		1.65 / 4.70			
OP266D		0.54 / NA			
OP266W		1.00 / NA			



RoHS

## General Note

TT Electronics reserves the right to make changes in product specification without notice or liability. All information is subject to TT Electronics' own data and is considered accurate at time of going to print.

TT Electronics | OPTEK Technology  
2900 E. Plano Pkwy, Plano, TX 75074 | Ph: +1 972 323 2200  
www.ttelectronics.com | sensors@ttelectronics.com

# Plastic Infrared Emitting Diode

OP265 (A, B), OP266 (A, B, D, W)

Obsolete (OP265D, OP265W)



## OP265 (A, B)

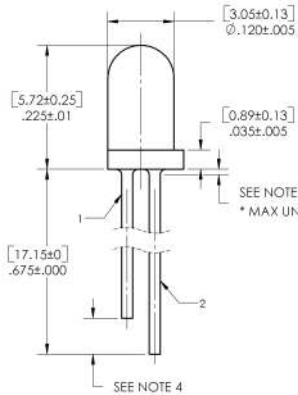

- NOTES:
1. OUTSIDE DISCRETE SHELL IS POLYSULFONE P1700 **CLEAR**.
  2. THIS LED IS BUILT WITH A 0.011 X 0.011 GGAIA'S CHIP.
  3. MAX ALLOWABLE EPOXY MINISCUS IS 0.030.
  4. FOR IDENTIFICATION PURPOSES, ANODE LEAD IS .065 ± .035 LONGER THAN THE CATHODE LEAD.

### DISCRETE PIN-OUT

- 1 CATHODE
- 2 ANODE

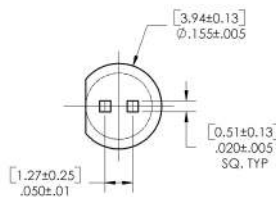

DIMENSIONS ARE IN: [MILLIMETERS] INCHES

## OP266 (A, B, D)

\* MAX UNDERFILL ALLOWED IS .015".  
\*\* ELBOW OF LEADFRAME NOT MORE THAN .005" FROM FLANGE.

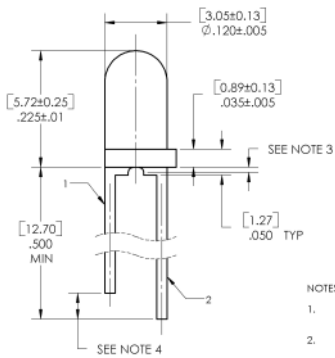

- NOTES:
1. OUTSIDE DISCRETE SHELL IS POLYSULFONE P1700 **CLEAR**.
  2. THIS LED IS BUILT WITH A 0.011 X 0.011 GGAIA'S CHIP.
  3. MAX ALLOWABLE EPOXY MINISCUS IS 0.030.
  4. FOR IDENTIFICATION PURPOSES, ANODE LEAD IS .050 MIN LONGER THAN THE CATHODE LEAD.

### DISCRETE PIN-OUT

- 1 CATHODE
- 2 ANODE

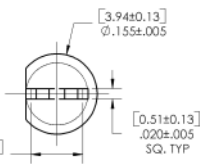

## OP266W

\* MAX UNDERFILL ALLOWED IS .015".  
\*\* ELBOW OF LEADFRAME NOT MORE THAN .005" FROM FLANGE.

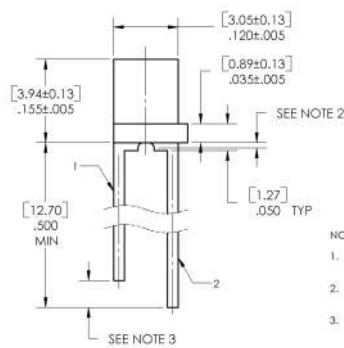

- NOTES:
1. OUTSIDE DISCRETE SHELL IS POLYSULFONE P1700 **CLEAR**.
  2. MAX ALLOWABLE EPOXY MINISCUS IS 0.030.
  3. FOR IDENTIFICATION PURPOSES, ANODE LEAD IS .050 NOM. LONGER THAN THE CATHODE LEAD.

### DISCRETE PIN-OUT

- 1 CATHODE
- 2 ANODE

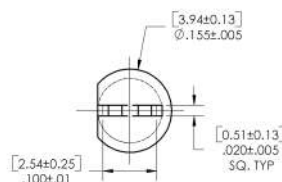

Pin #	LED
1	Cathode
2	Anode

### CONTAINS POLYSULFONE

To avoid stress cracking, we suggest using ND Industries' **Vibra-Tite** for thread-locking. **Vibra-Tite** evaporates fast without causing structural failure in OPTEK's molded plastics.

### General Note

TT Electronics reserves the right to make changes in product specification without notice or liability. All information is subject to TT Electronics' own data and is considered accurate at time of going to print.

TT Electronics | OPTEK Technology  
2900 E. Plano Pkwy, Plano, TX 75074 | Ph: +1 972 323 2200  
www.ttelectronics.com | sensors@ttelectronics.com

# Plastic Infrared Emitting Diode

OP265 (A, B), OP266 (A, B, D, W)

Obsolete (OP265D, OP265W)



## Electrical Specifications

**Absolute Maximum Ratings** ( $T_A = 25^\circ\text{C}$  unless otherwise noted)

Storage and Operating Temperature Range	-40° C to +100° C
Reverse Voltage	2.0 V
Continuous Forward Current	50 mA
Peak Forward Current (1 $\mu\text{s}$ pulse width, 300 pps)	3.0 A
Lead Soldering Temperature [1/16 inch (1.6 mm) from case for 5 seconds with soldering iron]	260° C
Power Dissipation	100 mW <sup>(1)</sup>

**Electrical Characteristics** ( $T_A = 25^\circ\text{C}$  unless otherwise noted)

SYMBOL	PARAMETER	MIN	TYP	MAX	UNITS	TEST CONDITIONS
Input Diode						
$E_{E(APT)}$	Apertured Radiant Incidence					
	OP265A, OP266A	2.70	-	-	mW/cm <sup>2</sup>	$I_F = 20\text{ mA}^{(2)}$
	OP265B, OP266B	1.65	-	4.70		
OP266D	0.54	-	-			
$P_O$	Radiant Power Output				mW	$I_F = 20\text{ mA}$
	OP265 (A, B), OP266 (A, B, D) OP266W	- 1.00	- -	- -		
$V_F$	Forward Voltage	-	-	1.80	V	$I_F = 20\text{ mA}$
$I_R$	Reverse Current	-	-	100	$\mu\text{A}$	$V_R = 2\text{ V}$
$\lambda_P$	Wavelength at Peak Emission	-	890	-	nm	$I_F = 10\text{ mA}$
B	Spectral Bandwidth between Half Power Points	-	80	-	nm	$I_F = 10\text{ mA}$
$\Delta\lambda_P / \Delta T$	Spectral Shift with Temperature				nm/° C	$I_F = \text{Constant}$
	OP265 (A, B), OP266 (A, B, D) OP266W	- -	$\pm 0.30$ $\pm 0.18$	- -		
$\theta_{HP}$	Emission Angle at Half Power Points				Degree	$I_F = 20\text{ mA}$
	OP265 (A, B), OP266 (A, B, D) OP266W	- -	18 90	- -		
$t_r$	Output Rise Time	-	500	-	ns	$I_{F(PK)} = 100\text{ mA}$ , PW = 10 $\mu\text{s}$ , D.C. = 10.0 %
$t_f$	Output Fall Time	-	250	-	ns	$I_{F(PK)} = 100\text{ mA}$ , PW = 10 $\mu\text{s}$ , D.C. = 10.0 %

Notes:

- Derate linearly 1.33 mW/° C above 25° C
- $E_{E(APT)}$  is a measurement of the average apertured radiant incidence upon a sensing area 0.081" (2.06 mm) in diameter, perpendicular to and centered on the mechanical axis of the lens, and 0.590" (14.99 mm) from the measurement surface.  $E_{E(APT)}$  is not necessarily uniform within the measured areas.

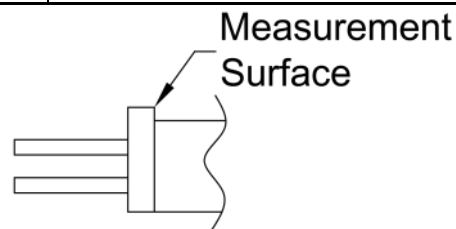

**General Note**

TT Electronics reserves the right to make changes in product specification without notice or liability. All information is subject to TT Electronics' own data and is considered accurate at time of going to print.

TT Electronics | OPTEK Technology  
2900 E. Plano Pkwy, Plano, TX 75074 | Ph: +1 972 323 2200  
www.ttelectronics.com | sensors@ttelectronics.com

# Plastic Infrared Emitting Diode

OP265 (A, B), OP266 (A, B, D, W)

Obsolete (OP265D, OP265W)



## Performance

OP265 (A, B), OP266 (A, B, D, W)

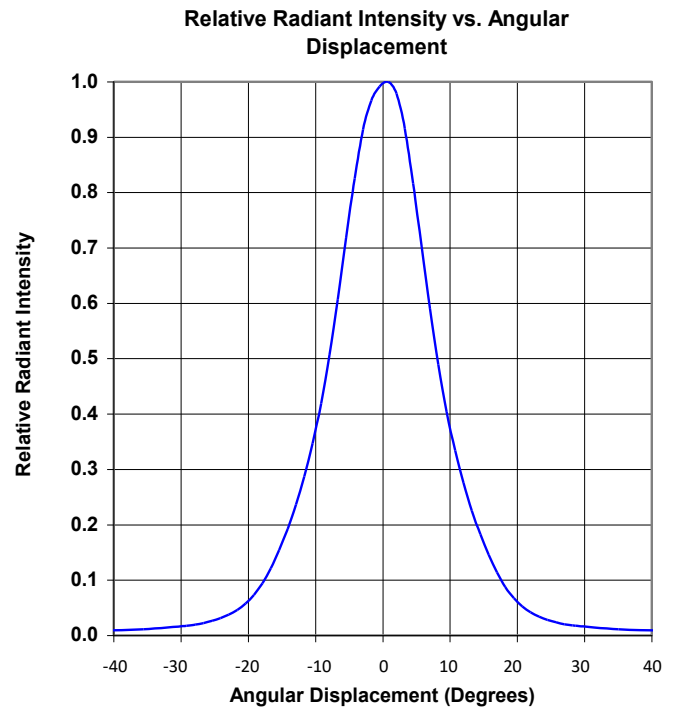
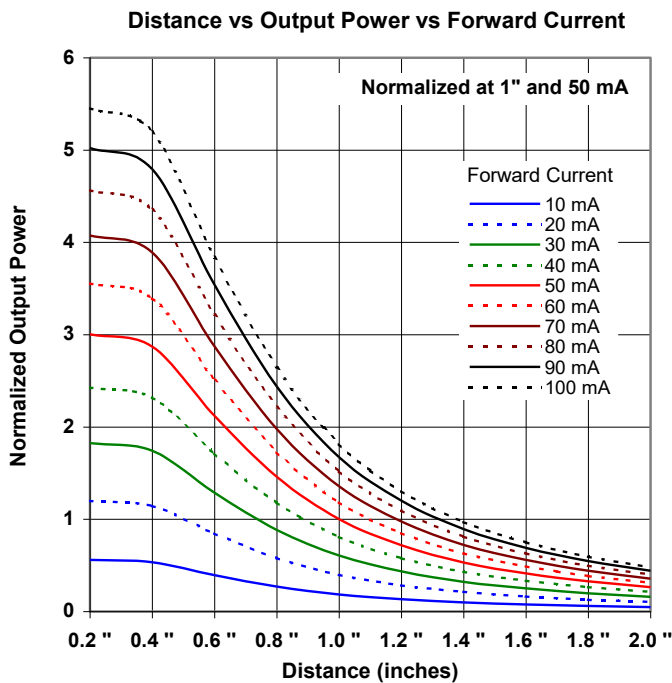
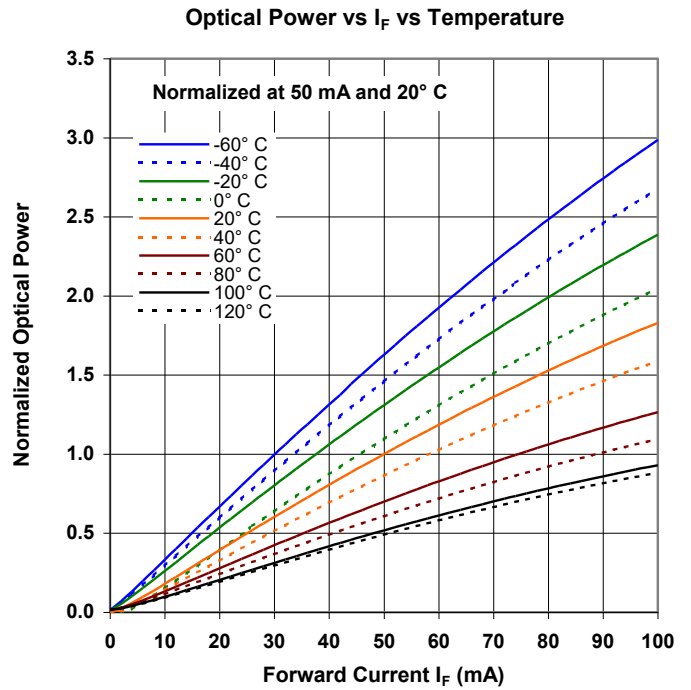
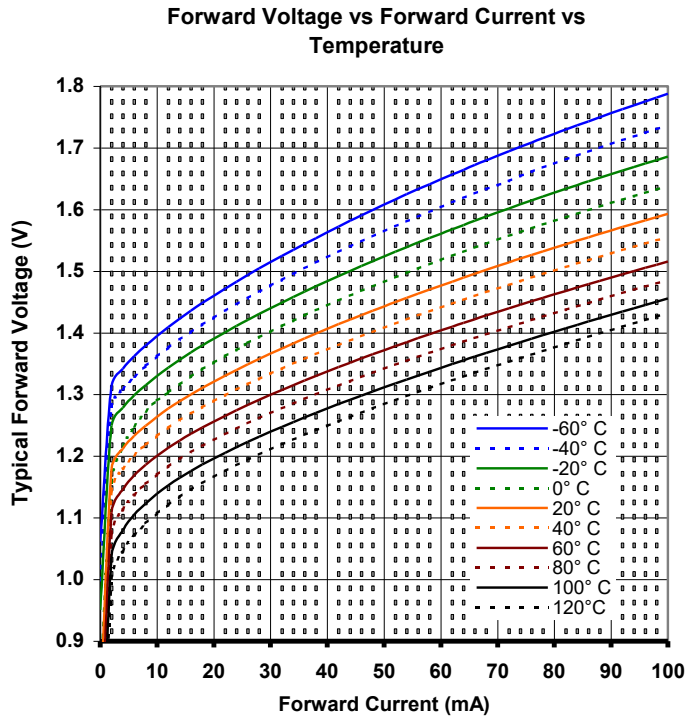

**General Note**

TT Electronics reserves the right to make changes in product specification without notice or liability. All information is subject to TT Electronics' own data and is considered accurate at time of going to print.

TT Electronics | OPTEK Technology  
 2900 E. Plano Pkwy, Plano, TX 75074 | Ph: +1 972 323 2200  
[www.ttelectronics.com](http://www.ttelectronics.com) | [sensors@ttelectronics.com](mailto:sensors@ttelectronics.com)