

**STRAIGHT MALE RECEPTACLE FOR PCB**

**R112.426.000**

**SOLDER LEGS**

Series : SMC

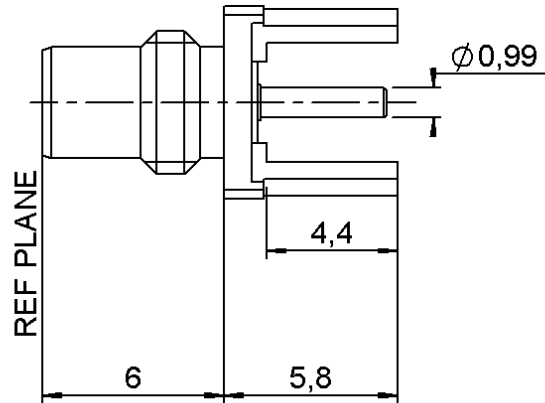
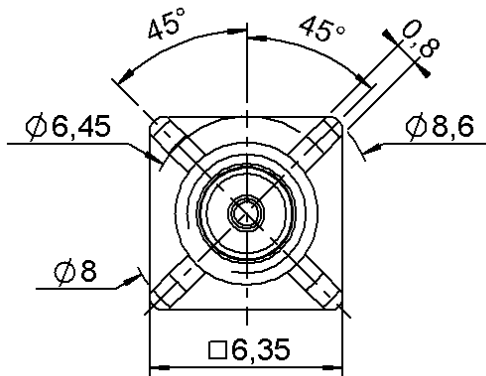

**PANEL CUT OUT**

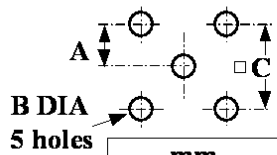

mm		
	Maxi	mini
A	2.59	2.49
B	1.4	1.3
C	5.00	5.16

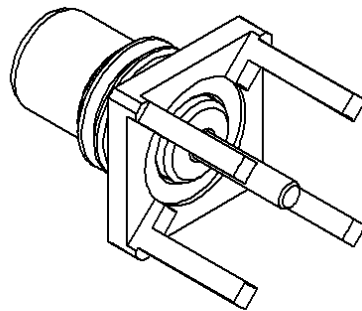
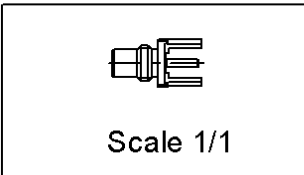

All dimensions are in mm.



COMPONENTS	MATERIALS	PLATINGS (µm)
BODY	BRASS	GOLD 0.2 OVER NICKEL 2
CENTER CONTACT	BRASS	GOLD 1.3 OVER NICKEL 2
OUTER CONTACT	-	-
INSULATOR	PTFE	-
GASKET	-	-
OTHERS PARTS	-	-
-	-	-
-	-	-

Issue : 0723 B

In the effort to improve our products, we reserve the right to make changes judged to be necessary.



**STRAIGHT MALE RECEPTACLE FOR PCB**

**R112.426.000**

**SOLDER LEGS**

Series : SMC

**PACKAGING**

**SPECIFICATION**

Standard	Unit	Other
<b>1</b>	-	<b>Contact us</b>

**ELECTRICAL CHARACTERISTICS**

**ENVIRONMENTAL**

Impedance	<b>50</b>	$\Omega$
Frequency	<b>0-10</b>	GHz
VSWR	<b>1.05 + 0,0300</b>	x F(GHz) Maxi
Insertion loss	<b>0.03*</b>	$\sqrt{F}$ (GHz) dB Maxi
RF leakage	- ( <b>62</b> )	- F(GHz)) dB Maxi
Voltage rating	<b>335</b>	Veff Maxi
Dielectric withstanding voltage	<b>1000</b>	Veff mini
Insulation resistance	<b>1000</b>	M $\Omega$ mini

Operating temperature	<b>-65/+165</b>	$^{\circ}$ C
Hermetic seal	<b>NA</b>	Atm.cm3/s
Panel leakage	<b>NA</b>	

**OTHERS CHARACTERISTICS**

Assembly instruction **NA**

Others :

\* Coaxial Transmission Line Only

**MECHANICAL CHARACTERISTICS**

Center contact retention		
Axial force – Mating end	<b>10</b>	N mini
Axial force – Opposite end	<b>10</b>	N mini
Torque	<b>NA</b>	N.cm mini
Recommended torque		
Mating	<b>NA</b>	N.cm
Panel nut	<b>NA</b>	N.cm
Mating life	<b>500</b>	Cycles mini
Weight	<b>0,7390</b>	g

Issue : 0723 B

In the effort to improve our products, we reserve the right to make changes judged to be necessary.

