

©1961 BY AMP INCORPORATED. ALL RIGHTS RESERVED. AMP PRODUCTS COVERED BY PATENTS AND/OR PATENTS PENDING.

REVISIONS				
ZONE	LTR	DESCRIPTION	DATE	APPROVED
	L	REDRAWN WITHOUT CHANGE W-868	9-24-5	m.s./d.h.
	M	OBS-6.7 ECNDF0949	2A 11-88	JW
	N	REV. Per. 063D-54A-02	CT 12-03	CT
	P	ECO-10-020499	PY 15FEB11	DE

NUMBER 66086

MAX. EXTENSION BEYOND BACK FACE OF BLOCK.

BACK FACE OF BLOCK.

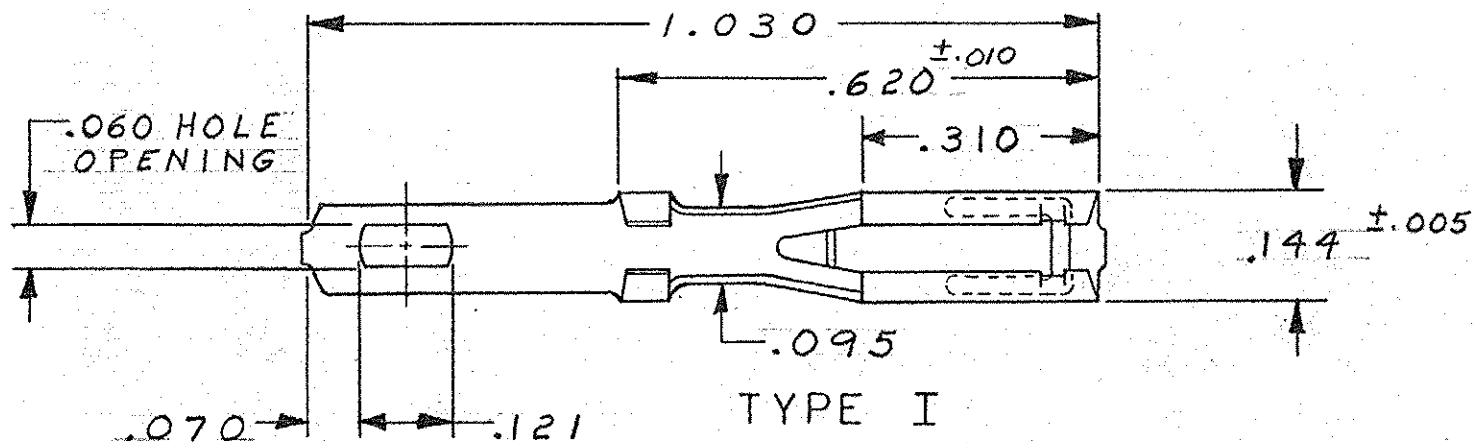

TYPE I

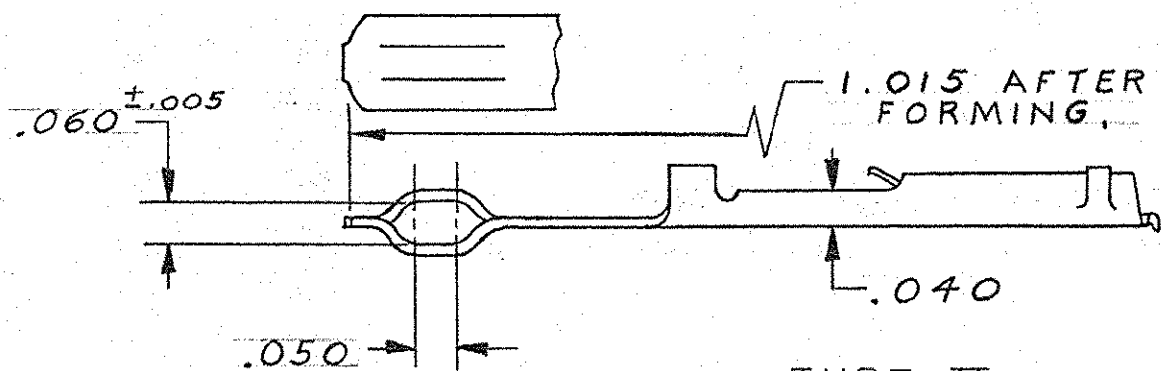

TYPE II

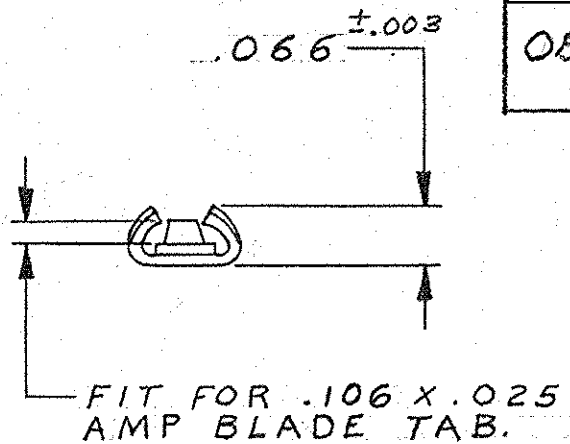

TERMINAL NUMBER	A	TYPE	FINISH
66086-2	.390	I	GOLD
OBS	-3	II	
OBS	-4	III	
	-5	I	
	-6	II	
OBS	66086-7	.375	III

NOTE: 1. FOR SUPPLEMENTAL SPECIFICATIONS SEE E.S. 8-1-3.

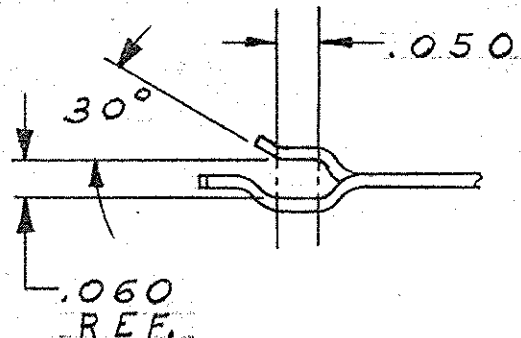

TYPE III

UNLESS OTHERWISE SPECIFIED DIM. ARE IN INCHES. TOLERANCES ON: DECIMALS ±.015 ANGLES ± 0°30'	CONTRACT NO.	AMP INCORPORATED HARRISBURG, PENNSYLVANIA	
	DR <i>M. Smith</i> 9-23-65	AMP	
MATERIAL PHOS. BRONZE	CHK. <i>S. Heide</i> 11/3/65	NAME AMP BLADE RECP. WITH SOLDER TAB	
HEAT TREAT H	APPD <i>E. Mendon</i> 11/3/65	SIZE B	REV P
LOC DF	PRINT DIST <i>M. HO</i>	CODE IDENT NO. 00779	NUMBER 66086
FINISH SEE TABLE	OTHER APPD <i>R. Holliday</i> 11/3/65	SCALE 4-1	WT CALC ACTUAL SHEET 1 OF 1