

REVISIONS					
REV	ECO	DESCRIPTION	DATE	BY	APPR
A1	-	RELEASE NEW DRAWING	11APR18	ROOKIE	TOMMY
A2	-	REVISED DESCRIPTION	12JUN19	JAH	DH
A3	-	UPDATE THE APPEARANCE	11NOV21	RONALD	TOMMY

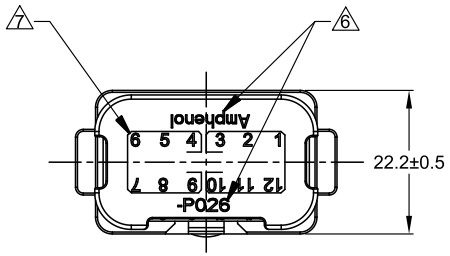
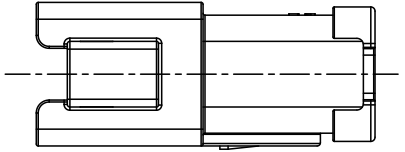
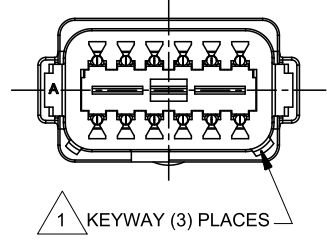
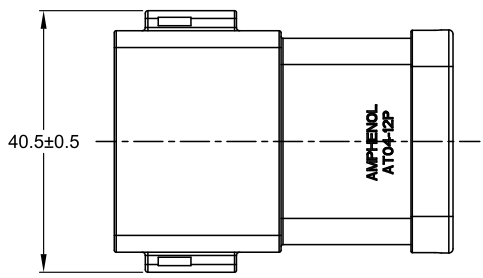

NOTES: UNLESS OTHERWISE SPECIFIED

1 SEE SHEET 2 FOR KEY ARRANGEMENTS AND COLORS.

2. MATERIAL:  
HOUSING: THERMOPLASTIC  
SEAL: SILICONE RUBBER  
CONTACT: COPPER ALLOY

3. MODIFICATIONS: 2 PIECES OF 6 PIN BUSBAR WITH NICKEL PLATED

4. SPECIFICATIONS:  
4.1 CURRENT RATING: 39 AMPS MAXIMUM FOR THE 6 PIN BUSBAR  
4.2 OPERATING TEMPERATURE: -55°C TO +125°C.  
4.3 DIELECTRIC WITHSTANDING VOLTAGE: LESS THAN 2 MILLIAMPS CURRENT LEAKAGE @ 1500 VOLTS AC.  
4.4 INSULATION RESISTANCE: 1000 MEGOHM MIN @ 25°C.  
4.5 MOISTURE RESISTANCE: IP69K & IP68 (1M OF WATER FOR A PERIOD OF 24 HOURS, MATED CONDITION)  
4.6 MATING CYCLE DURABILITY: 100 CYCLES  
4.7 RoHS COMPLIANT

5. MATING PART: AT06-12SX\* PLUG  
(X=A,B,C,D KEYS \* = AVAILABLE MODIFICATIONS)

6. ORIENTATION OF "Amphenol" AND "-P026" TO BE OPTIONAL

7. BORDERS SIGNIFY THAT PINS 1,2,3,10,11,12 AND PINS 4,5,6,7,8,9 ARE BUSSED TOGETHER WITH 6 PIN BUSBARS

8. ALL DIMENSIONS ARE FOR REFERENCE USE ONLY.

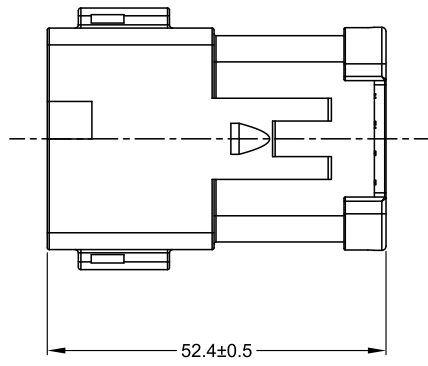

1 REFER TO SHEET 2 FOR AVAILABLE CONNECTOR COLORS

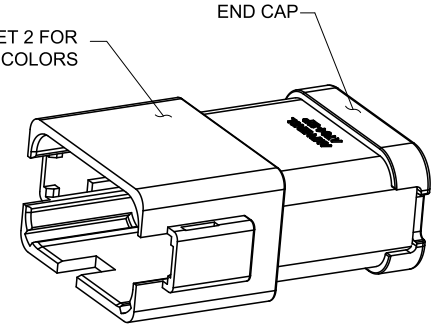

SEE SHEET 2		REF: DT04-12PA-P026 & DT04-12PB-P026	
PART NUMBER		DESCRIPTION	
ITEM		ITEM	
QUANTITY			
MATERIALS LIST			
UNLESS OTHERWISE SPECIFIED		SIGNATURES DATE	
1) All dimensions are in metric (mm).		DRAWN: RONALD 11NOV21	
2) Tolerances are as follows:		CHECKED: ORION 12NOV21	
1 PL DEC ±0.30   Fractions ±1/64		ENGINEER:	
2 PL DEC ±0.15   Angles ±1°		APPROVAL: TOMMY 15NOV21	
3) Note reference = 1		CUSTOMER:	
MATERIAL SPECIFICATIONS:		THIS DRAWING IS SUPPLIED FOR INFORMATION ONLY. DESIGN FEATURES, SPECIFICATIONS AND PERFORMANCE DATA SHOWN HEREON ARE THE PROPERTY OF THE AMPHENOL CORPORATION. NO RIGHTS OF REPRODUCTION ARE IMPLIED. ALL DIMENSIONS ARE SUBJECT TO NORMAL MANUFACTURING VARIATIONS.	
WEIGHT: 28.1g		SIZE: B	
PROCESS SPECIFICATIONS:		TYPE: C-	
NEXT ASSY:		DWG NO: AT04-12PX-P026	
		REVISION: A3	
		SCALE: NONE	
		SHEET 1 OF 2	

TITLE: HYPERBUSS AT 12WAY RECP (2) 6 PIN BUSBAR NI-PLATED  
DWG NO: AT04-12PX-P026  
REV: A3  
SH: 1  
OF: 2

REVISIONS					
REV	ECO	DESCRIPTION	DATE	BY	APPR
A1	-	RELEASE NEW DRAWING	11APR18	ROOKIE	TOMMY
A2	-	REVISED DESCRIPTION	12JUN19	JAH	DH
A3	-	UPDATE THE APPEARANCE	11NOV21	RONALD	TOMMY

P/N AT04-12PA-P026  
KEY-A CONFIGURATION  
STANDARD COLOR: GREY

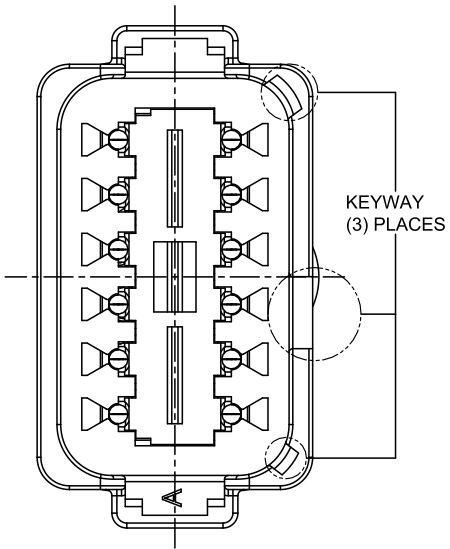

P/N AT04-12PB-P026  
KEY-B CONFIGURATION  
STANDARD COLOR: BLACK

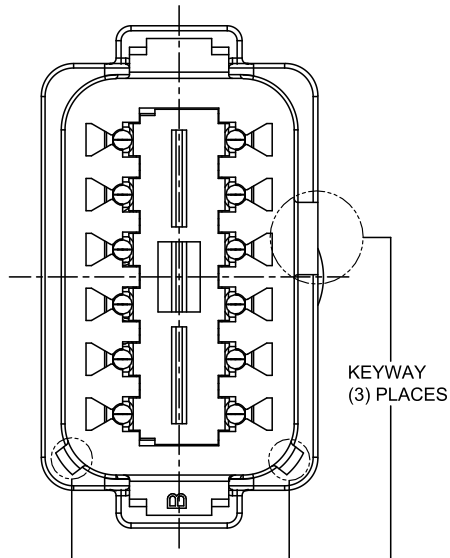

P/N AT04-12PC-P026  
KEY-C CONFIGURATION  
STANDARD COLOR: GREEN

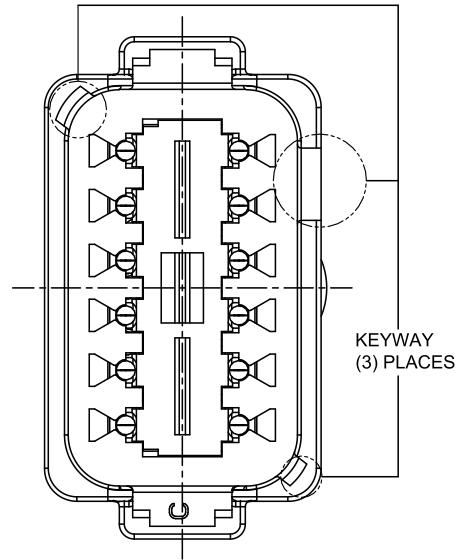

P/N AT04-12PD-P026  
KEY-D CONFIGURATION  
STANDARD COLOR: BROWN

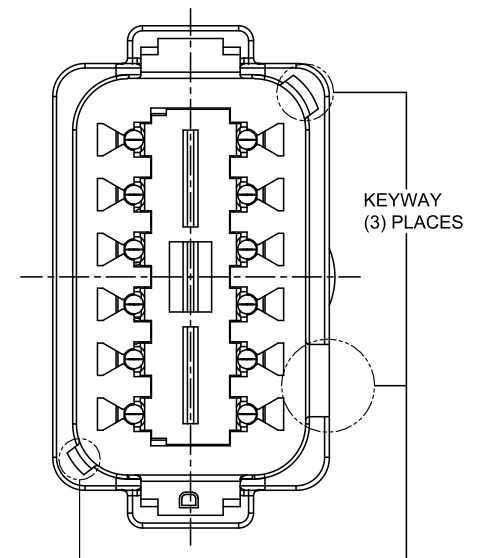

TITLE: HYPERBUSS AT 12WAY RECP (2)6 PIN BUSBAR NI-PLATED  
DWG NO: AT04-12PX-P026  
REV: A3  
SH: 2  
OF: 2

QUANTITY	PART NUMBER	DESCRIPTION	ITEM										
<b>MATERIALS LIST</b>													
<small>UNLESS OTHERWISE SPECIFIED</small> 1) All dimensions are in metric(mm). 2) Tolerances are as follows: 1 PL DEC ±0.30   Fractions ±1/64 2 PL DEC ±0.15   Angles ±1° 3 PL DEC ±0.08 3) Note reference =		<table border="1"> <thead> <tr> <th>SIGNATURES</th> <th>DATE</th> </tr> </thead> <tbody> <tr> <td>DRAWN: RONALD</td> <td>11NOV21</td> </tr> <tr> <td>CHECKED: ORION</td> <td>12NOV21</td> </tr> <tr> <td>ENGINEER:</td> <td></td> </tr> <tr> <td>APPROVAL: TOMMY</td> <td>15NOV21</td> </tr> </tbody> </table>	SIGNATURES	DATE	DRAWN: RONALD	11NOV21	CHECKED: ORION	12NOV21	ENGINEER:		APPROVAL: TOMMY	15NOV21	<h1>Amphenol</h1> <p>Sine Systems - www.amphenol-sine.com 44724 Morley Drive Clinton Township, MI 48036</p>
SIGNATURES	DATE												
DRAWN: RONALD	11NOV21												
CHECKED: ORION	12NOV21												
ENGINEER:													
APPROVAL: TOMMY	15NOV21												
MATERIAL SPECIFICATIONS: <b>WEIGHT:28.1g</b>		CUSTOMER: THIS DRAWING IS SUPPLIED FOR INFORMATION ONLY. DESIGN FEATURES, SPECIFICATIONS AND PERFORMANCE DATA SHOWN HEREON ARE THE PROPERTY OF THE AMPHENOL CORPORATION. NO RIGHTS OF REPRODUCTION ARE IMPLIED. ALL DIMENSIONS ARE SUBJECT TO NORMAL MANUFACTURING VARIATIONS.											
PROCESS SPECIFICATIONS: NEXT ASSY:		SIZE: <b>B C-</b> SCALE: <b>NONE</b>	DWG NO: <b>AT04-12PX-P026</b> REVISION: <b>A3</b> SHEET <b>2</b> OF <b>2</b>										