

## Data Sheet

### Description

The MSA-0870 is a high performance silicon bipolar Monolithic Microwave Integrated Circuit (MMIC) housed in a hermetic, high reliability package. This MMIC is designed for use as a general purpose 50Ω gain block above 0.5 GHz and can be used as a high gain transistor below this frequency. Typical applications include narrow and moderate band IF and RF amplifiers in industrial and military applications.

The MSA-series is fabricated using Avago's 10 GHz  $f_T$ , 25 GHz  $f_{MAX}$ , silicon bipolar MMIC process which uses nitride self-alignment, ion implantation, and gold metallization to achieve excellent performance, uniformity and reliability. The use of an external bias resistor for temperature and current stability also allows bias flexibility.

### Features

- Usable Gain to 6.0 GHz
- High Gain:  
32.5 dB Typical at 0.1 GHz  
23.5 dB Typical at 1.0 GHz
- Low Noise Figure:  
3.0 dB Typical at 1.0 GHz
- Hermetic Gold-ceramic Microstrip Package

### 70 mil Package

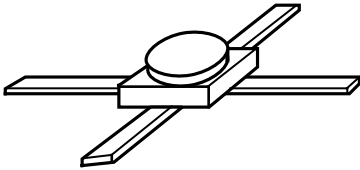

### Typical Biasing Configuration

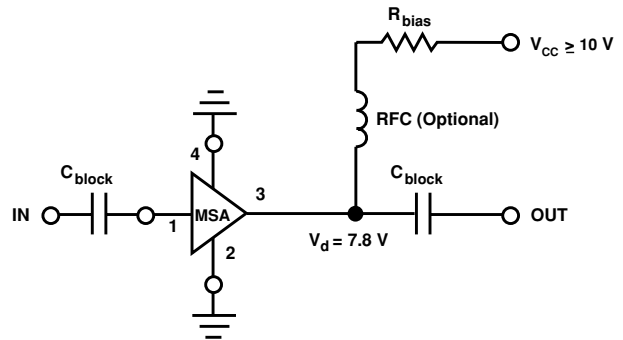

## MSA-0870 Absolute Maximum Ratings

Parameter	Absolute Maximum <sup>[1]</sup>
Device Current	80 mA
Power Dissipation <sup>[2,3]</sup>	750 mW
RF Input Power	+13 dBm
Junction Temperature	200°C
Storage Temperature	-65°C to 200°C

Thermal Resistance<sup>[2,4]</sup>:

$$\theta_{jc} = 150^{\circ}\text{C}/\text{W}$$

Notes:

1. Permanent damage may occur if any of these limits are exceeded.
2.  $T_{\text{CASE}} = 25^{\circ}\text{C}$ .
3. Derate at  $6.7 \text{ mW}/^{\circ}\text{C}$  for  $T_{\text{C}} > 88^{\circ}\text{C}$ .
4. The small spot size of this technique results in a higher, though more accurate determination of  $\theta_{jc}$  than do alternate methods.

## Electrical Specifications<sup>[1]</sup>, $T_{\text{A}} = 25^{\circ}\text{C}$

Symbol	Parameters and Test Conditions: $I_{\text{d}} = 36 \text{ mA}$ , $Z_0 = 50 \Omega$	Units	Min.	Typ.	Max.
$G_{\text{p}}$	Power Gain ( $ S_{21} ^2$ )	$f = 0.1 \text{ GHz}$			32.5
		$f = 1.0 \text{ GHz}$		22.0	23.5
		$f = 4.0 \text{ GHz}$			11.0
VSWR	Input VSWR	$f = 1.0 \text{ to } 3.0 \text{ GHz}$			2.0:1
	Output VSWR	$f = 1.0 \text{ to } 3.0 \text{ GHz}$			1.9:1
NF	50 $\Omega$ Noise Figure	$f = 1.0 \text{ GHz}$			3.0
$P_{1 \text{ dB}}$	Output Power at 1 dB Gain Compression	$f = 1.0 \text{ GHz}$			12.5
$IP_3$	Third Order Intercept Point	$f = 1.0 \text{ GHz}$			27.0
$t_{\text{D}}$	Group Delay	$f = 1.0 \text{ GHz}$			125
$V_{\text{d}}$	Device Voltage		7.0	7.8	8.4
$dV/dT$	Device Voltage Temperature Coefficient				-17.0

Note:

1. The recommended operating current range for this device is 20 to 40 mA.  
Typical performance as a function of current is on the following page.

MSA-0870 Typical Scattering Parameters<sup>[1]</sup> ( $Z_0 = 50 \Omega$ ,  $T_A = 25^\circ\text{C}$ ,  $I_d = 36 \text{ mA}$ )

Freq. GHz	$S_{11}$			$S_{21}$			$S_{12}$		$S_{22}$		k
	Mag	Ang	dB	Mag	Ang	dB	Mag	Ang	Mag	Ang	
0.1	.65	-19	32.5	42.04	161	-36.3	.015	40	.64	-22	0.78
0.2	.60	-35	31.5	37.54	145	-33.7	.021	47	.58	-43	0.66
0.4	.48	-60	29.1	28.49	122	-30.5	.030	51	.47	-74	0.64
0.6	.40	-76	26.8	21.90	108	-28.0	.040	50	.38	-97	0.72
0.8	.35	-88	24.9	17.48	97	-26.2	.049	50	.33	-113	0.78
1.0	.32	-102	23.4	14.85	87	-24.9	.057	51	.28	-128	0.83
1.5	.29	-118	20.1	10.14	70	-23.0	.071	47	.22	-151	0.91
2.0	.30	-133	17.6	7.55	56	-21.9	.081	45	.16	-167	0.98
2.5	.31	-139	15.6	6.01	49	-20.0	.100	46	.12	-172	1.02
3.0	.32	-149	13.8	4.87	39	-19.5	.106	41	.07	-170	1.11
3.5	.34	-159	12.2	4.09	28	-18.4	.121	35	.07	-143	1.12
4.0	.34	-168	10.8	3.48	17	-17.7	.131	31	.12	-112	1.16
5.0	.33	161	8.4	2.63	-3	-16.6	.147	21	.19	-103	1.26
6.0	.39	128	6.2	2.04	-22	-16.2	.155	10	.21	-115	1.36

Typical Performance,  $T_A = 25^\circ\text{C}$

(unless otherwise noted)

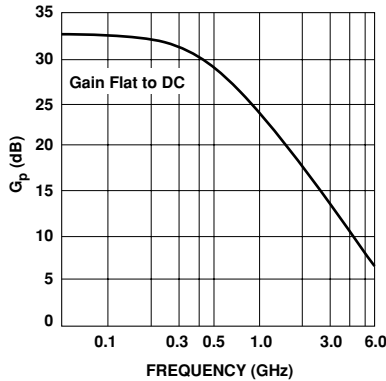

Figure 1. Typical Power Gain vs. Frequency,  $I_d = 36 \text{ mA}$ .

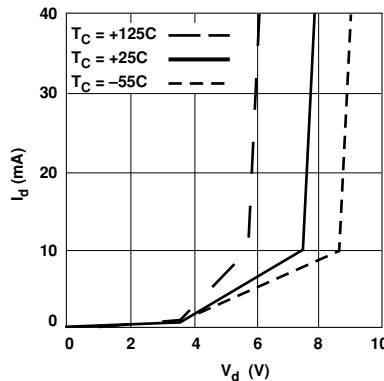

Figure 2. Device Current vs. Voltage.

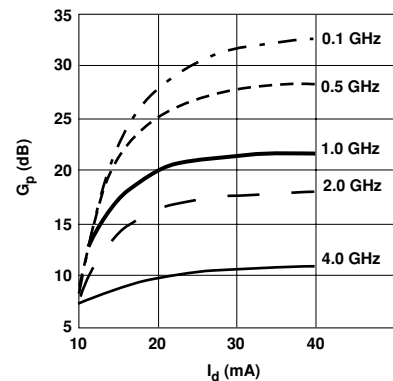

Figure 3. Power Gain vs. Current.

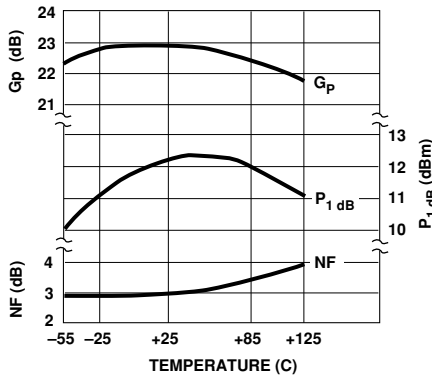

Figure 4. Output Power at 1 dB Gain Compression, NF and Power Gain vs. Case Temperature,  $f = 1.0 \text{ GHz}$ ,  $I_d = 36 \text{ mA}$ .

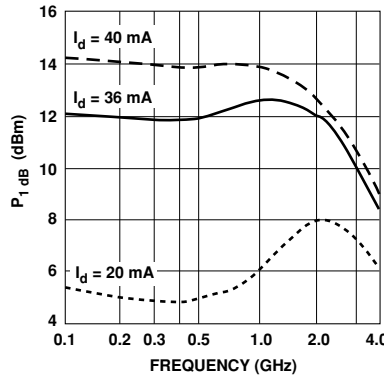

Figure 5. Output Power at 1 dB Gain Compression vs. Frequency.

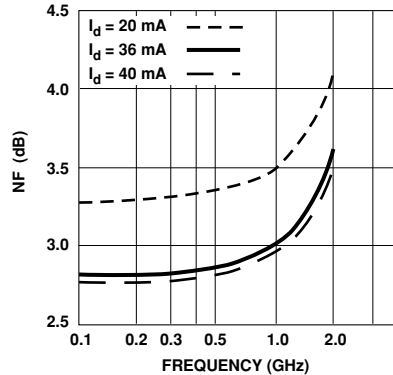
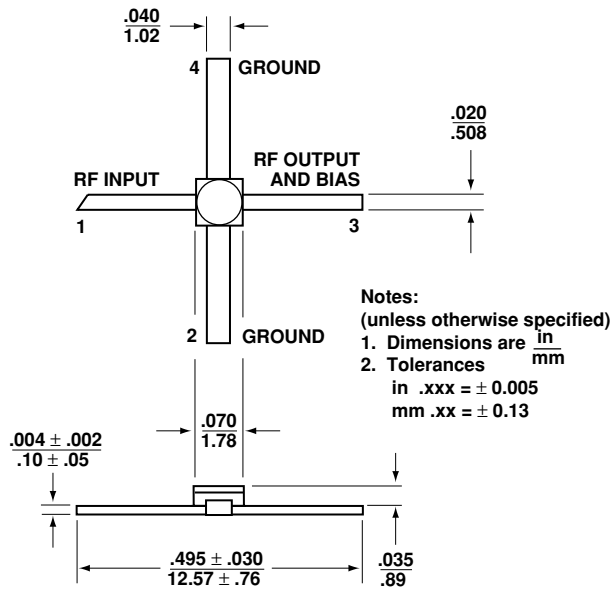

Figure 6. Noise Figure vs. Frequency.

## Ordering Information

Part Numbers	No. of Devices	Comments
MSA-0870	100	Bulk

## 70 mil Package Dimensions



For product information and a complete list of distributors, please go to our web site: [www.avagotech.com](http://www.avagotech.com)

Avago, Avago Technologies, and the A logo are trademarks of Avago Technologies, Limited in the United States and other countries. Data subject to change. Copyright © 2008 Avago Technologies, Limited. All rights reserved. Obsoletes 5989-2768EN AV02-1231EN - May 15, 2008

**AVAGO**  
TECHNOLOGIES