

LDC		DIST		REVISIONS			
P	LTR	DESCRIPTION		DATE	DWN	APVD	
		D3	ECR-21-123594	03FEB2022	RK	JB	

POS. 1 AS SHOWN / wie dargestellt



- PACKAGING
  - TRANSPORT CASE, 60 x 20 x 11MM
  - Verpackt
  - Transportkoffer, 60 x 20 x 11mm
- CUSTOMER MANUAL WILL BE INCLUDED IN CASE, IN LANGUAGE ENGLISH AND GERMAN  
Bedienungsanleitung ist dem Koffer beigelegt, in der Landessprache englisch und deutsch.

Allgemeine Daten

Hydraulic hand-operated tool HP 60 H with H-compression head, rotating 180°  
 - Double piston pump for rapid motion of the die-set  
 - Automatic safety relief valve to avoid overpressure  
 - Force of pressure: 60 kN

Hydraulische Handzange HP 60 H mit H-Presskopf, 180° drehbar  
 - Doppelkolben-Pumpe für schnelles Anfahren des Presseinsatzes  
 - Automatisches Überdruck-Sicherheitsventil  
 - Presskraft: 60 kN

HEX DIE SET FOR HYDRAULIC HANDTOOL 60 KN, CONSISTING OF 2 HEX DIE SET COMPONENTS (AS SHOWN) / SECHSKANT-PRESSEINSATZ FÜR HYDR. HANDZANGE 60 KN, BESTEHEND AUS 2-KOMPONENTEN (WIE GEZEICHNET)

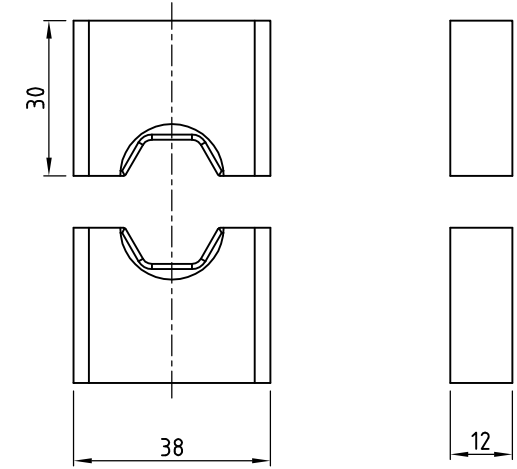

13	185 SQ.MM	25	1-1110956-3	C	HEX DIE SET, 185 QMM, KZ 25	BLACK / BRONZED
12	-	-	1-1110956-2	C	<b>OBSOLETE</b>	-
11	35 SQ.MM	12	1-1110956-1	C	<b>OBSOLETE</b>	BLACK / BRONZED
10	25 SQ.MM	10	1-1110956-0	C	HEX DIE SET, 25 QMM, KZ 10	BLACK / BRONZED
9	16 SQ.MM	8	1110956-9	C	HEX DIE SET, 16 QMM, KZ 8	BLACK / BRONZED
8	10 SQ.MM	6	1110956-8	C	HEX DIE SET, 10 QMM, KZ 6	BLACK / BRONZED
7	SET 1	14-22	1110956-7	D	<b>OBSOLETE</b>	GREEN / BLACK
6	150 SQ.MM	22	1110956-6	C	<b>OBSOLETE</b>	BLACK / BRONZED
5	120 SQ.MM	20	1110956-5	C	<b>OBSOLETE</b>	BLACK / BRONZED
4	95 SQ.MM	18	1110956-4	C	<b>OBSOLETE</b>	BLACK / BRONZED
3	70 SQ.MM	16	1110956-3	C	<b>OBSOLETE</b>	BLACK / BRONZED
2	50 SQ.MM	14	1110956-2	C	HEX DIE SET, 50 QMM, KZ 14	BLACK / BRONZED
1	-	-	1110956-1	D	<b>OBSOLETE</b>	GREEN / BLACK
POS	SECTION / Querschnitt	INDEX / Kennzeichen	TE P/N	REV	DESCRIPTION/BEZEICHNUNG	COLOUR/FINISH FARBE/OBERFLAECHE

THIS DRAWING IS A CONTROLLED DOCUMENT.

DWN	Braun	15MAY00
CHK	Schnurpfeil	15MAY00
APVD	Schnurpfeil	15MAY00

TE Connectivity

HYDRAULIC HAND TOOL 60KN, HEX DIE SETS DIN 48083

SIZE	A3	CAGE CODE	00779	DRAWING NO	C=1110956	RESTRICTED TO	-
CUSTOMER DRAWING						SCALE	-
						SHEET	1 OF 1
						REV	D3